

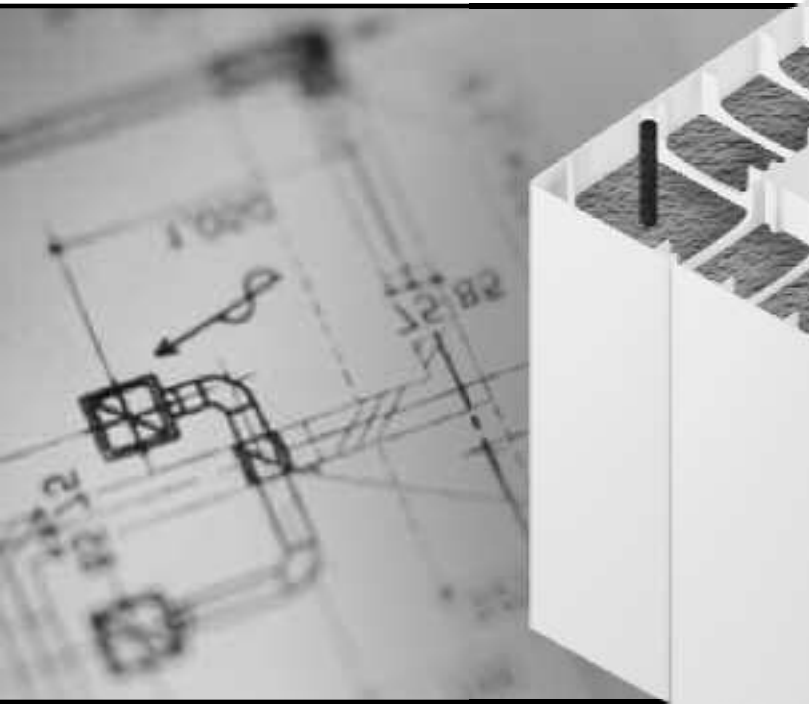

The Pre-Finished, Stay-in-Place
Concrete Wall Formwork

Technical Guide



Version 2.0



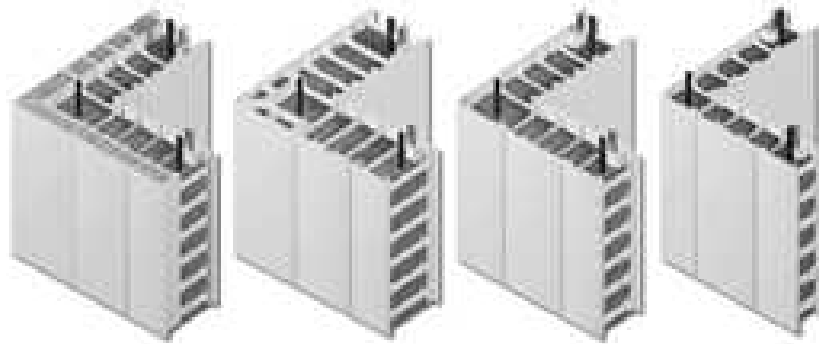

Building Solutions for a Better World...

Nuform Building Technologies Inc. is an innovative quality-driven building technologies company. Since the introduction of CONFORM® (formerly Royal Building Systems™) in 1992, the product has received global recognition for its approach in providing an innovative solution to the construction industry.

CONFORM is a patented polymer-based stay-in-place formwork for concrete walls. The extruded components slide and interconnect together to create a concrete formwork. The result is permanent, attractive, and pre-finished concrete walls that can be easily constructed in any climate.

CONFORM is composed of numerous modular components for 100mm, 150mm and 200mm (4", 6" and 8") concrete walls that can be assembled to suit any wall layout, whether you are building a vehicle wash, an agricultural facility or a large industrial building.

CONFORM requires no painting, and resists ultra-violet radiation. The polymer components will not decay or deteriorate over a lifespan that can be measured in decades. Furthermore, CONFORM is highly durable, virtually maintenance free, impervious to weather, and energy efficient.

CONFORM is manufactured using 'R3' extrusion technology as an environmentally friendly product. The polymer components contain over 55% recycled content and are recyclable, energy efficient, mold and mildew resistant and non-toxic.

CONFORM offers complete design flexibility and an innovative building product that is easy to maintain, friendly to the environment, and built to last. Whether you are a developer, contractor, architect, engineer, or designer you can find attractive and cost effective solutions for your next project with CONFORM.



Contents

1. Introduction	1
2. CONFORM® Formwork	1
2.1 Components	1
2.2 Layout	5
2.3. Heights	5
2.4 Wall Openings	6
2.5 Properties	7
3. Concrete Walls with CONFORM®	9
3.1 Concrete Mix	9
3.2 Concrete Placement	9
3.3. Concrete Takeoff	10
4. Code Evaluations and Technical Publications	11
4.1 Code Evaluations	11
4.2 National Building Code of Canada, 2010	11
4.3 Ontario Building Code	13
4.4 International Building Code, 2009 (USA)	13
4.5 International Residential Code	15
4.6 Florida Building Code	15
4.7 Third Party Evaluations	15
4.8 Technical Publications	16
4.9 Past Evaluations	17
5. Product Performance	18
5.1 Material Performance	18
5.2 Structural Performance of Concrete Walls with CONFORM®	18
5.3 Fire Performance	19
5.4 Sustainability of CONFORM®	20
5.5 Energy Performance	22
5.6 Vapor and Air Barriers	24
5.7 Water Penetration	24
5.8 Indoor Air Quality (IAQ)	24
5.9 Acoustic Performance	25
5.10 Longevity and Weatherability	26
6. Specifications	27
Section 03 11 33 - Polymer Concrete Formwork	27

1. Introduction

This Technical Guide has been prepared by Nuform Building Technologies Inc. (NUFORM®) to assist architects, engineers, builders and contractors in understanding and designing structures using CONFORM®. It is a part of our continuing effort to provide current and practical information to users of CONFORM.

The Technical Guide provides information on the following aspects of CONFORM:

- CONFORM Formwork
- Concrete Walls with CONFORM
- Code Evaluations
- Product Performance
- Product Specifications

In addition to the Technical Guide, the following guides are also available to assist in designing and building your projects using CONFORM:

- Engineering Guide
- Construction Guide

Although every effort has been made to ensure that all the information provided in the Technical Guide is factual and that the numerical values are accurate and consistent with current engineering practice, NUFORM does not assume any liability for errors or oversights resulting from the use of information contained in this guide. Anyone making use of the information provided in these guides assumes all liability arising from such use.

2. CONFORM® Formwork

2.1 Components

CONFORM® uses extruded rigid polymer components that serve as a pre-finished, stay-in-place formwork for concrete walls including bearing walls, non-bearing walls, shear walls, retaining walls and foundation walls. The extruded components slide and interconnect together to create a concrete formwork that remains in place after the concrete is poured and cured. CONFORM provides permanent, low maintenance, interior and exterior wall finishes.

Four types or thicknesses of CONFORM are available:

CF4 (100 mm or 4")

CF6 (150 mm or 6")

CF8 (200 mm or 8")

CF8i (200 mm or 8", pre-insulated).

Table 2.1 CONFORM

CONFORM	Size	Concrete Wall Thickness	Insulation
CF4	100 mm (4")	95 mm (3.74")	0
CF6	150 mm (6")	145 mm (5.71")	0
CF8	200 mm (8")	195 mm (7.68")	0
CF8i ⁽¹⁾	200 mm (8")	139 mm (5.47")	54 mm (2.13")

Refer to Table 2.1 and Figure 2.2.

(1) The CF8i components are pre-insulated with 54 mm (2.13") of polyurethane insulation. The insulation cavity is on the exterior side of the wall and is protected from the interior with the non-combustible concrete core.

Figure 2.2 CONFORM

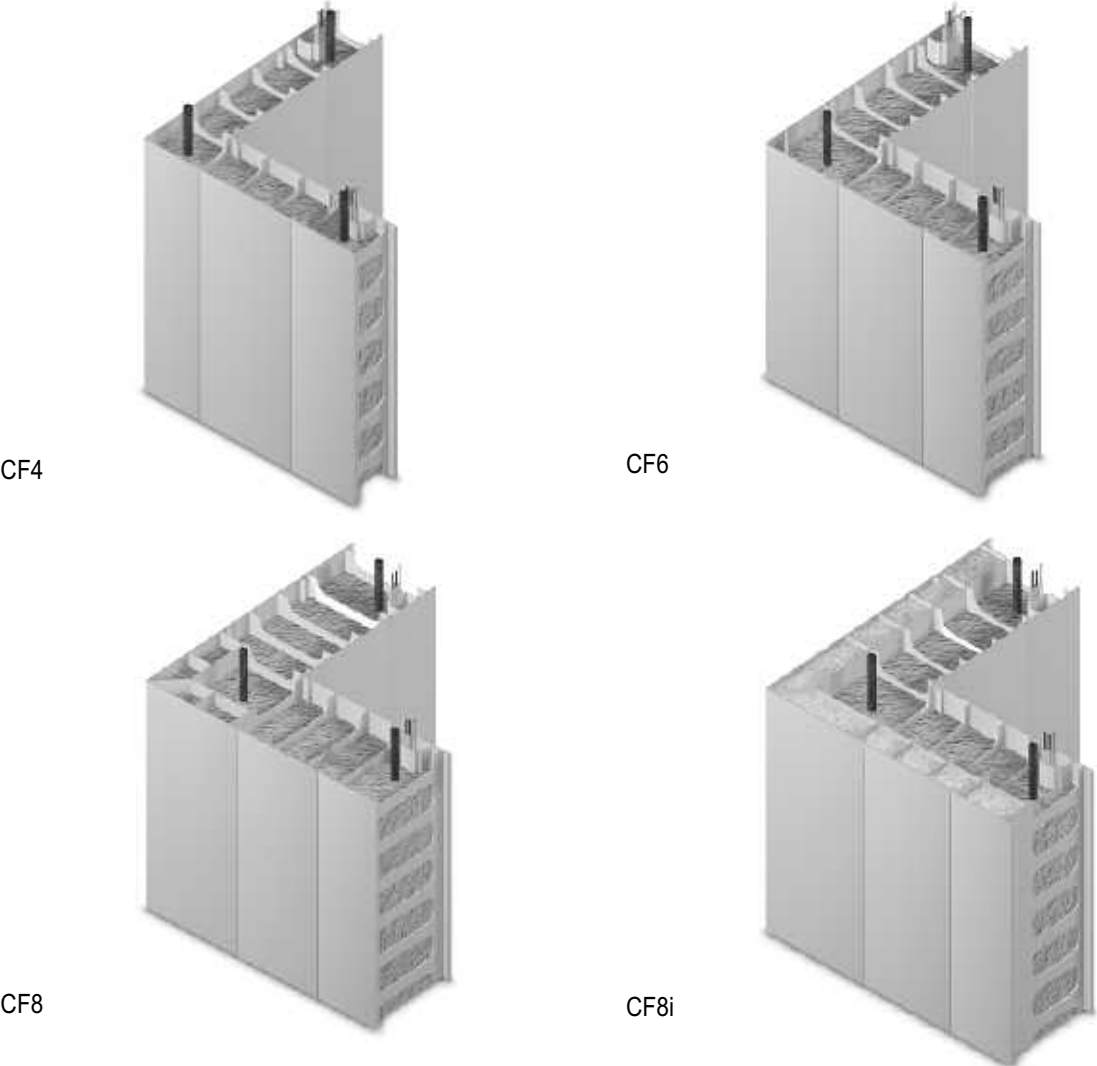

Each type of CONFORM creates a wall formwork using a variety of components. The two most commonly used components, for each wall thickness, are the straight box connector and the panel 232, which are 100 mm (4") and 232 mm (9") wide respectively.

CF4 components are used for walls of small structures. The various CF4 components are shown in Figure 2.3.

Typically, CF6 and CF8 components are used for bearing and non-bearing walls where no thermal insulation is required. The various CF6 components are shown in Figure 2.4, and the various CF8 components are shown in Figure 2.5.

CF8i components are used for insulated, exterior, bearing and non-bearing walls. The various CF8i components are shown in Figure 2.6.

The flexibility of the system allows for the combining of all four types in order to accommodate a wide variety of structures and construction applications.

Accessory and trim components are available to provide a finishing touch to CONFORM.

The CONFORM components are available in two standard colors: tan and white

Fig 2.3 CF4 Components

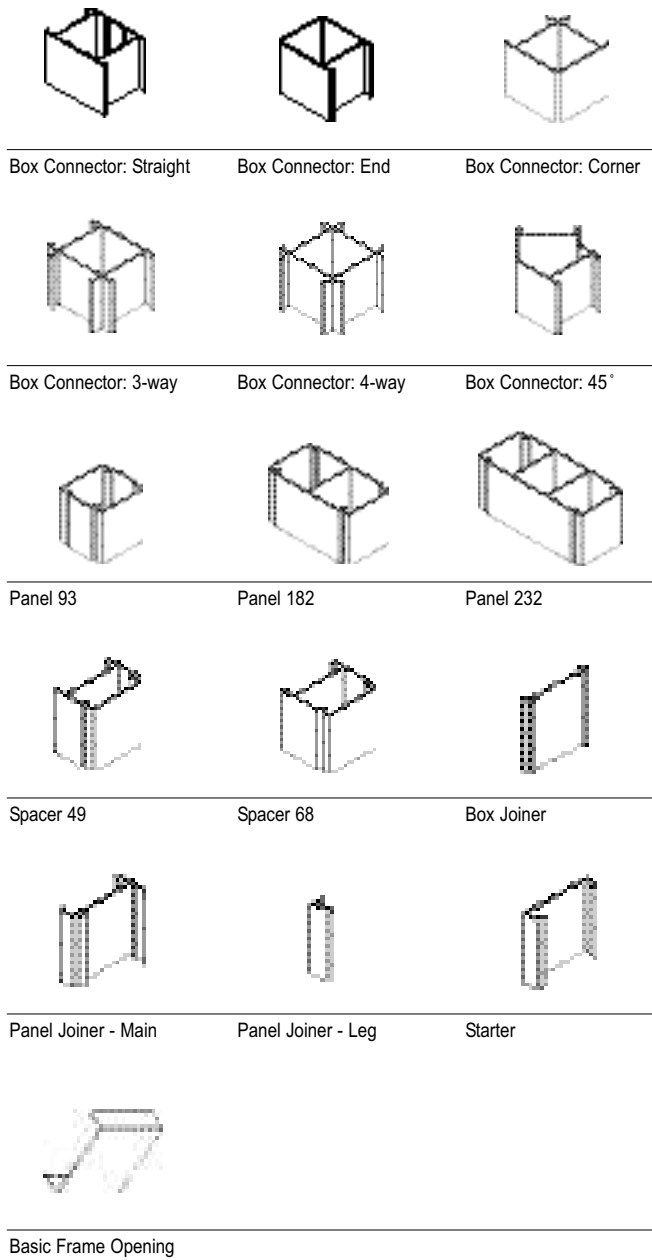

Fig 2.4 CF6 Components

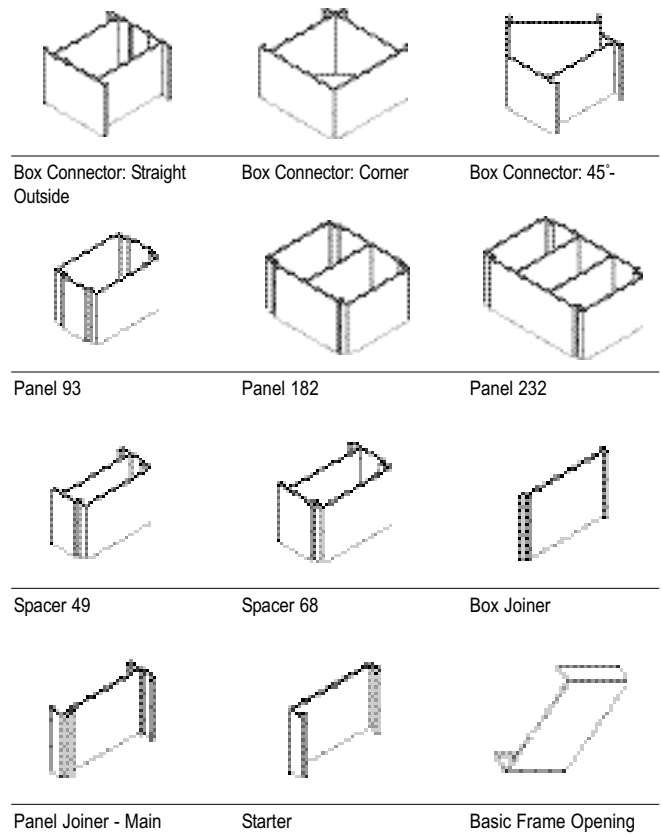

Fig 2.5 CF8 Components

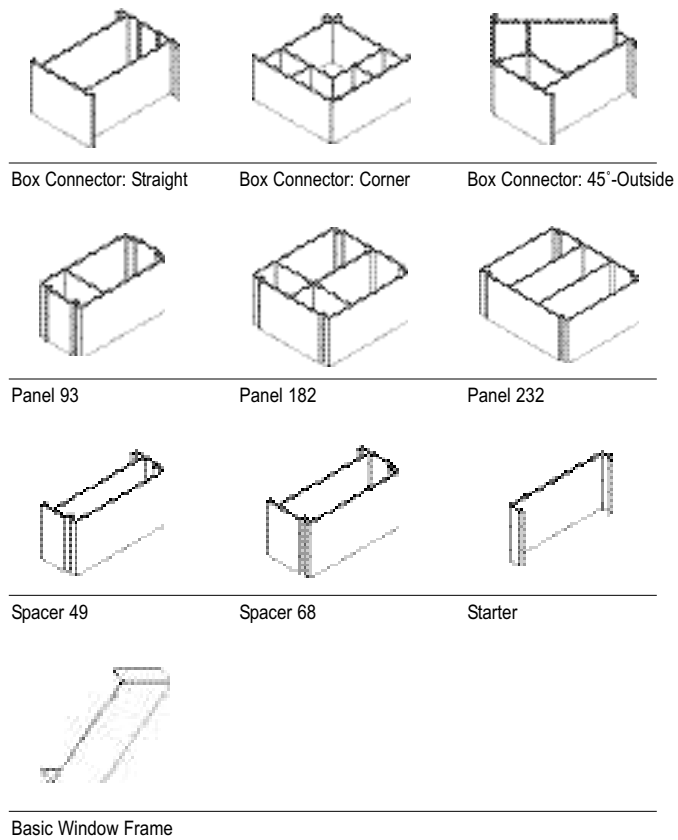
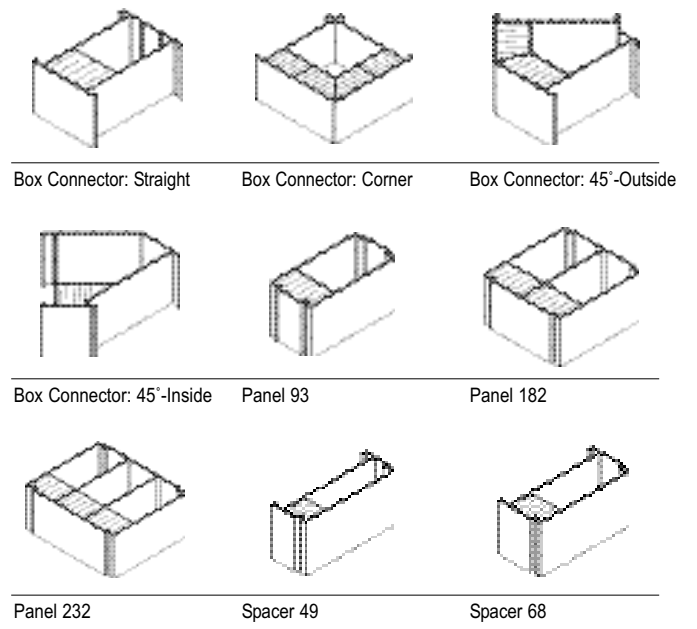

Fig 2.6 CF8i Components



2.2 Layout

CONFORM components were developed to suit a 333.33 mm (1' 1 1/8") or 1000 mm (3' 3 3/8") grid, as shown in the Figure 2.7. The 333.33 mm grid is composed of 100 mm (4 ") for the box connector, and 233.33 mm (9 1/8") for the panel P232.

It is important to note that the dimension of 233.33 mm for the panel is composed of 232.03 mm for the actual panel and a 0.65 mm joint gap at each side of the panel. All panels and spacers include a joint gap and therefore the length of wall created by a panel or spacer is greater than the actual component size. However, panels and spacers are named by component size and not by the wall length dimension. It is essential to consider the actual wall length created rather than the component dimension in calculating the length of a wall.

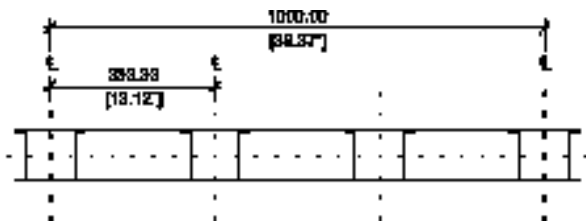

Fig. 2.7

The other components provide for corners, intersections and alternate panel dimensions to suit the location of wall intersections, doors, and windows; and the coring is aligned.

All CONFORM components are cored. That is, the webs of the profiles are punched. This allows the horizontal flow of concrete between the elements. Cores are punched starting from the top of the component. The start of the first core is located at 37 mm (1 1/2") from the top end of the component and the subsequent cores are 83.3 mm (3 1/4") apart.

For stepped or sloped walls, the components are extruded longer to the nearest 83.3 increment and fabricated to the exact length required, in order to align the coring horizontally.

Each component is labelled to match the erection drawings.

2.3 Heights

The CONFORM components are manufactured through a continuous extrusion process and are pre-cut to the required lengths for each specific project.

For walls that are over 6500 mm (21') high, the individual boxes and panels are split into two or more lengths. The joints in the boxes and panels are staggered near mid height. For pre-assembled wall sections, the staggered joint is typically 1500 mm (5') high and is not less than 900 mm (3'-0"). The panels with the longest length and the boxes with the shortest length are placed at the bottom of the walls. The horizontal joints in the CONFORM components do not affect the concrete pour and concrete remains monolithic. The joints are concealed with an architectural, 'multi-storey', band.

For large projects, CONFORM wall sections are usually pre-assembled at the manufacturing facility. The maximum width of pre-assembled sections is 2233 mm (7'-4") to suit shipping and handling. The CONFORM components of a wall section are screwed together at the webs. For high wall sections with staggered joints, the members are screwed together on the exterior face, at the staggered joints.

2.4 Wall Openings

The design flexibility of CONFORM can accommodate almost any opening size. Various combinations of box connectors, panels and spacer components can accommodate almost any opening width and the opening height can be cut to suit any height. Doors, windows and frames supplied by third parties will work with CONFORM, as long as the appropriate rough opening size is specified.

By using all the available components, and specifically the Spacer 49 (50 mm) (2") and Spacer 68 (69.5 mm) (2 ¾"), it is possible to achieve most opening sizes within 20 mm (¾").

Where hollow metal doors are installed, the opening must be specified to accommodate the frame size. The components are selected to suit the width of typical hollow metal frames using a panel with a starter at each jamb. The typical man door openings are shown in Table 2.8.

Where 6 mm (¼") bent steel plates are used for overhead door openings, the components are specified to suit. The typical overhead door openings are shown in Table 2.9.

Table 2.8 Man Door Openings

Opening Width			
Door	Frame	CONFORM Opening	CONFORM Header Components
3' 0" 915 mm	3' 4" 1017 mm	3' 4 ⅜" 1026 mm	Bx/P232/Bx/P93/S68/Bx/P232/Bx
4' 0" 1219 mm	4' 4" 1321 mm	4' 4 ¼" 1327 mm	Bx/P232/Bx/P182/Bx/P182/Bx/P232/Bx
6' 0" 1829 mm	6' 4" 1931 mm	6' 4 ½" 1944 mm	Bx/P232/Bx/P232/Bx/P182/Bx/P182/Bx/P182/Bx/P232/Bx
8' 0" 2438 mm	8' 4" 2540 mm	8' 4 ¼" 2547 mm	Bx/S68/P232/Bx/P232/Bx/P232/Bx/P232/Bx/P232/Bx/P232/Bx/P232/S49/Bx
Opening Height			
Door	Frame	CONFORM Opening	CONFORM Header Components
7' 0" 2134 mm	7' 2" 2185 mm	7' 2 ¼" 2191 mm	To suit wall height
8' 0" 2438 mm	8' 2" 2489 mm	8' 2 ¼" 2496 mm	To suit wall height

Table 2.9 Overhead Door Openings

Opening Width		
Door	CONFORM Opening	CONFORM Header Components
10' 0" 3048 mm	9' 11 ⅜" 3044 mm	10 Boxes, 8 Panels 232, 1 Panel 182
12' 0" 3658 mm	12' 0 ⅛" 3661 mm	12 Boxes, 9 Panels 232, 2 Panel 182
14' 0" 4267 mm	13' 11 ⅝" 4257 mm	14 Boxes, 10 Panels 232, 2 Panel 182, 1 Panel P93, 1 Spacer 68
16' 0" 4877 mm	15' 11 ⅞" 4874 mm	16 Boxes, 11 Panels 232, 3 Panel 182, 1 Panel P93, 1 Spacer 68
Opening Height		
Door	CONFORM Opening	CONFORM Header Components
10' 0" 3048 mm	10' 0 ¼" 3054 mm	To suit wall height
12' 0" 3658 mm	12' 0 ¼" 3664 mm	To suit wall height

2.5 Properties

The polymer material used in CONFORM is designated as 'Royalloy B'. Royalloy B is a rigid polymer, a polyvinyl chloride composite material, that has been specifically blended to produce a set of properties suitable for the performance and durability of CONFORM. Royalloy B is a unique combination of recycled PVC materials, additive blend materials and virgin PVC resins.

The physical properties of Royalloy B were originally established, in 1992, based on detailed requirements specified by the Canadian Construction Materials Centre (CCMC) at the National Research Centre of Canada (NRC). Subsequently as "green" materials and sustainability were demanded by the construction industry, the composition of Royalloy B was modified to introduce the use of recycled PVC materials. However, a comprehensive list of tests was established to verify compliance with the appropriate CCMC requirements, and these tests are conducted on a continuing basis.

Royalloy B is a co-extruded combination of two materials; a virgin UV resistant capstock compound and a substrate of NUFORM Blend that contains up to 85% recycled material. This results in a rigid PVC compound that is a complex composition of recycled material, virgin polyvinyl chloride resins, acrylic modifiers, waxes, lubricants, tin stabilizer (lead stabilizers are not used), ultraviolet ray protectant and smoke and flame suppressants. The resulting PVC material has a cell classification of 1 211 2332 0040, as per ASTM D4216.

The polymer material provides an interior and exterior finish for both interior and exterior concrete walls. The material complies with the National Building Code of Canada and the International Building Code of USA. CONFORM provides a class A interior finish with a hard smooth surface and a semi-gloss appearance. The polymer provides a durable, UV and water resistant layer that can withstand many corrosive chemicals, needs minimal maintenance and cleans easily with power washing.

The material properties of the polymer composite, 'Royalloy B', are shown in Table 2.10

Table 2.10: Materials Properties of Royalloy B

Property	ASTM Test Method	CCMC Requirement ⁽²⁾	Results ⁽³⁾
Notched Izod Impact Resistance	D256	> 53.4 > 1.0	240 J/m 4.5 ft/lb/in
Drop Dart Impact (Procedures A & B)	D4226	> 4450 > 1.0	4890 J/m 1.1 in/lb/mil
Tensile Strength	D638	> 37.7 MPa > 5500 psi	> 40.0 MPa > 5800 psi
Tensile Modulus	D638	> 2600 MPa > 377,000 psi	> 3150 MPa > 456,000 psi
Elongation at Yield	D638	(n/a)	2.5%
Elongation at Break	D638	(n/a)	48%
Heat Deflection Temperature (load 1.82 MPa) annealed at 65°C	D648	> 70°C > 158°F	73.9°C 165°F
Coefficient of Linear Expansion	D696	< 6.0 x 10 ⁻⁵ cm/cm/°C < 3.3 x 10 ⁻⁵ in/in/°F	5.0 x 10 ⁻⁵ cm/cm/°C 2.8 x 10 ⁻⁵ in/in/°F
Hardness (Rockwell)	D785	report value	102
Flexural Strength	D790	(n/a)	70.9 MPa 10,280 psi
Flexural Modulus	D790	(n/a)	2880 MPa 417,600 psi
Specific Gravity	D792	report value	1.47
Hardness (Shore D)	D2240	80 ± 5	77
Shrinkage (1/2 hr @ 82°C)	D3679	max 3%	1.77%

(2) These are the CCMC requirements, except as noted (n/a)

(3) Values are taken from tests reports and may not be representative of actual product

3. Concrete Walls with CONFORM®

3.1 Concrete Mix

Concrete comprises more than 90% (by mass and volume) of the walls with CONFORM®. The architect or engineer shall specify the concrete mix required for each specific project. The concrete mix proportions and the types of aggregates are selected to meet the specified strength and to provide a workability that allows the mix to flow through the coring without vibration. The workability is dependent on the cement content, the aggregate size and shape, the water content and the weather conditions during placement. Concrete with the following minimum specifications are suggested for ease of placement:

- Minimum 28-day compressive strength
 - 20 MPa (3000 psi)
- Minimum 28-day strength with air entrainment
 - 25 MPa (3500 psi) for freeze-thaw conditions
- Maximum water to cement ratio – 0.55
- Maximum aggregate size
 - 10 mm (3/8") rounded stone (pea gravel)
- Minimum slump
 - 100 mm to 125 mm (4" to 5") at the point of discharge
- Water reducing admixture
- Air entrainment of 5-7% for freeze-thaw conditions, where applicable.

To achieve the high slump and desired flow, the mix will have a high cement content and in many cases higher than is required for the specified compressive strength. For heavily reinforced walls, the slump have to be slightly higher to ensure that the concrete is in full contact with the reinforcing steel bars in the areas of congestion, such as in corners with hooked bars and in lintels with more than one layer of horizontal reinforcing steel.

The use of fly ash is not recommended since it tends to create a concrete mix that adheres to the inside of the CONFORM components and results in a poor concrete flow.

The use of plasticizers or super-plasticizers in the concrete mix is not recommended. Often, it is necessary to place the concrete at a slow pace and the time constraint of a plasticizer may not be suitable and may result in poor flowing concrete and poor consolidation.

3.2 Concrete Placement

Concrete does not segregate when placed in CONFORM due to the inner webs of the components. The webs create vertical cells that act like an "elephant trunk" and therefore prevent the free-fall of heavier aggregates. Concrete placed in CONFORM formwork does not normally need to be vibrated since the lightweight forms "self-vibrate" as the concrete is placed. Honeycombing should not occur if concrete is placed correctly with a suitable slump. However, a rubber mallet may be used to tap the sides of the walls to ensure that the components are completely filled with concrete. Mechanical pencil vibrators may be used, but only for conditions where poor slump or area of congestion, are restricting the flow of concrete. In these cases, extreme caution is taken to ensure that the concrete is not over-vibrated.

The fluid pressure on the face of the CONFORM components is significantly less than that experienced with conventional formwork. The large number of inner webs and coring create a bridging action and the numerous joints between the components relieve the pressure by bleeding the water and cement paste.

3.3 Concrete Take-off

The theoretical quantities of concrete for the various types of CONFORM are shown in Table 3.1 (Metric units) and Table 3.2 (Imperial units). Note that the actual quantity of concrete must be adjusted for wall openings, wastage and specific project conditions.

Table 3.1: Concrete Take-off (Metric Units)

	CF4	CF6	CF8	CF8i
	Square Metre of Wall Area			
Per Cubic Metre of Concrete	11.1 m ²	7.2 m ²	5.4 m ²	7.5 m ²
	Cubic Metre of Concrete			
Per Square Metre of Wall Area	0.0903 m ³	0.1385 m ³	0.1867 m ³	0.1336 m ³

Table 3.2: Concrete Take-off (Imperial Units)

	CF4	CF6	CF8	CF8i
	Square Foot of Wall Area			
Per Cubic Yard of Concrete	91 ft ²	59 ft ²	44 ft ²	61 ft ²
	Cubic Yard of Concrete			
Per Square Foot of Wall Area	0.0110 yd ³	0.0169 yd ³	0.0227 yd ³	0.0164 yd ³

4. Code Evaluations and Technical Publications

4.1 Code Evaluations

CONFORM® is a pre-finished, permanent formwork for cast-in-place concrete wall construction. A concrete wall with CONFORM consists of a non-combustible concrete wall, an interior face with a combustible finish and an exterior face with a combustible finish that may include polyurethane insulation in the case of CONFORM CF8i. The concrete wall may be a bearing or non-bearing wall and may be steel reinforced concrete or plain concrete.

There are a multitude of different types of buildings and occupancies where a concrete wall with CONFORM conforms to the requirements of Building Codes. The following is a summary of code evaluations, performance reviews and test results that may be applicable depending on the building type and occupancy.

4.2 National Building Code of Canada, 2010

It has been determined that CONFORM complies with the requirements of the 2010 National Building Code of Canada as follows:

4.2.1 Interior Finish Requirements

NBC 3.1.12 Flame Spread Rating and Smoke Developed Classification

3.1.12.1 Determination of Ratings

CONFORM formwork tested in conformance with CAN/ULC-S102.2 indicated that Flame-Spread rating (FS) is not more than 25 and Smoke Developed classification (SD) is not more than 350.

The foamed plastic insulation in CONFORM CF8i formwork tested in conformance with CAN/ULC-S102 indicated that Flame-Spread rating (FS) is not more than 25 and Smoke Developed classification (SD) is not more than 250.

NBC 3.1.13 Interior Finish

3.1.13.2(1) Flame Spread Rating

CONFORM formwork meets the code requirements of this article, FS not more than 25.

3.1.13.6 Corridors

CONFORM formwork meets the code requirements of this article, FS not more than 25.

3.1.13.7 High Buildings

CONFORM formwork is NOT permitted in high buildings, unless the building is sprinklered, since SD may exceed the maximum smoke developed classification of this article.

NBC 3.6.4 Horizontal Service Spaces and Service Facilities

3.6.4.3 Plenum Requirements

CONFORM formwork is NOT permitted in a concealed space used as a plenum, since SD exceeds the maximum smoke developed classification of this article.

4.2.2 Noncombustible Construction Requirements

NBC 3.1.5 Noncombustible Construction

3.1.5.1 Noncombustible Materials

Concrete with cross web of CONFORM, tested in accordance with CAN/ULC-S135, met the requirements for noncombustible construction.

3.1.5.2 Minor Combustible Components

The Building Materials Evaluation Commission of Ontario (BMEC) concluded that cross webs of CONFORM are minor combustible components permitted in noncombustible construction; as item h) other minor components

3.1.5.5 Combustible Components for Exterior Walls

The insulated CONFORM CF8i formwork was tested in conformance with CAN/ULC-S134 and met the requirements of this article.

3.1.5.10(2) Combustible Interior Finishes

CONFORM formwork meets the requirements of this article, FS not more than 25.

3.1.5.12 Combustible Insulation and its Protection

The insulation of CONFORM CF8i formwork meets the requirements of this article, FS not more than 25.

The exterior insulation of CONFORM CF8i formwork is protected from the adjacent space within the building by the cast-in-place concrete, as required by this article.

If the insulated face of the CONFORM CF8i formwork is exposed to adjacent space in the building, it must be protected as noted in article 3.5.1.12(2). This may occur where an insulated, exterior wall extends below a low roof.

NBC 3.1.7 Fire Resistance Ratings

3.1.7.1 Determination of Ratings

A bearing concrete wall with CONFORM CF6 formwork, tested in conformance with CAN/ULC-S101, indicated that it met the requirements of this article for a 2 hr fire rating.

Based on the CAN/ULC-S101 test, fire consultant, Locke MacKinnon Domingo Gibson & Associates Ltd. (LMDG) determined that walls with CONFORM CF8i formwork meet the requirements for a 2 hr fire rating.

NBC 3.1.9 Building Services in Fire Separations and Fire-Rated Assemblies

3.1.9.1 Fire Stopping of Service Penetrations

Fire stopping shall be provided as required and the combustible finish, CONFORM material, shall be removed where any fire stop materials are required to overlap the faces of the concrete wall.

4.2.3 Exterior Finish Requirements

NBC 3.2.3 Spatial Separation and Exposure Protection

3.2.3.7 Construction of Exposed Building Face

As per 3.2.3.7(3), the noncombustible cladding requirement of 3.2.3.7(2) are waived for Groups A, B, C, D and Group F Division 3 and for Groups E and Group F Divisions 1 or 2, where the maximum permitted area of unprotected openings is more than 10% of the exposed building face, since the wall assembly with CONFORM formwork complies the requirements of Article 3.1.5.5, when tested in conformance with CAN/ULC-S134.

As per 3.2.3.7(5), the noncombustible cladding requirement of 3.2.3.7(2) are waived for Groups A, B, C, D and Group F Division 3 and for Groups E and Group F Divisions 1 or 2, where the maximum permitted area of unprotected openings is more than 10% but not more than 25% of the exposed building face, since the wall assembly with CONFORM formwork complies the requirements of Article 3.1.5.5, when tested in conformance with CAN/ULC-S134.

3.2.3.8 Protection of Exterior Building Face

As per 3.2.3.8(3), the requirement for protection of foamed plastic insulation of 3.2.3.8(1) is waived, since the insulated CONFORM CF8i formwork complies the requirements of Article 3.1.5.5, when tested in conformance with CAN/ULC-S134.

4.2.4 Structural Requirements

NBC 4.3.3 Plain, Reinforced and Pre-stressed Concrete

4.3.3.1 Design Basis for Plain, Reinforced and Pre-stressed Concrete

Cast-in-place concrete walls constructed using CONFORM shall be designed in conformance with standard CSA A23.3 "Design of Concrete Structures", by a Professional Engineer skilled in such designs and licensed to practice under the appropriate legislation.

4.3 Ontario Building Code

The requirements of the Ontario Building Code are similar to the NBC, and therefore it has been determined that CONFORM complies with the requirements of the appropriate sections of the OBC code.

4.4 International Building Code, 2009 (USA)

It has been determined that CONFORM complies with the requirements of the 2009 International Building Code as follows:

4.4.1 Types of Construction

IBC 602.1 Construction Classification - General

Concrete walls with CONFORM formwork are permitted for Type I, II, III, IV and V construction in accordance with Table 601 and 602, provided that the fire resistance rating, as per 703.2, is not less than specified.

IBC 603.1.6 Combustible Material in Type I and II Construction

CONFORM is an allowable combustible material permitted in Type I and II construction since the interior wall finishes are in accordance with Sections 801 and 803.

4.4.2 Fire-Resistance Ratings and Fire Tests

IBC 703.2 Fire Resistance Ratings

Concrete walls with CONFORM CF6, CF8 or CF8i formwork meet the requirements for a 2 hr fire rating. A load bearing concrete wall with CONFORM CF6 formwork was tested in conformance with ASTM E119 (CAN/ULC-S101) for a 2 hr fire rating.

Based on a ASTM E119 (CAN/ULC-S101) test, fire consultant, Locke MacKinnon Domingo Gibson & Associates Ltd. (LMDG) determined that concrete walls with CONFORM CF6, CF8 and CF8i formwork meet the requirements for a 2 hr fire rating.

IBC 703.4.2 Noncombustibility Tests - Composite Materials

Concrete walls with CONFORM comply with the requirements for noncombustible construction in Types I, II, III and IV construction. The walls have a structural base of concrete, that is a noncombustible material. The CONFORM surface is less than 0.125" thick and has a Flame Spread Index (FSI) not more than 25 when tested in accordance with ASTM E84.

IBC 713. Penetrations

Fire stopping shall be provided as required and the combustible finish, CONFORM material, shall be removed where any fire stop materials are required to overlap the faces of the concrete wall.

IBC 717.5 Combustible Materials in Concealed Spaces in Type I or II Construction

Exposed CONFORM is NOT permitted in a concealed space used as a return air plenum except as permitted by Section 602 of the International Mechanical Code.

4.4.3 Interior Finishes

IBC 803.1.1 Interior Wall and Ceiling Finish Materials

CONFORM is a Class A material, for exposed interior wall finishes. CONFORM tested in accordance with ASTM E84, indicated that the Flame Spread Index (FSI) is not more than 25 and the Smoke Developed Index (SDI) is not more than 450.

4.4.4 Exterior Walls

IBC 1403.2 Weather Protection

Concrete walls with CONFORM may be left exposed to the exterior without any additional water resistive barrier. An exterior wall envelope with CONFORM resisted water penetration when tested in accordance with ASTM E331.

IBC 1406.2.1 Combustible Exterior Wall Coverings - Ignition Resistance

CONFORM complies with the requirements for exterior wall coverings where the fire separation distance is 5 feet or less. CONFORM was tested in accordance with NFPA 268 and did not exhibit sustained flaming.

4.4.6 Dampproofing and Waterproofing

IBC 1805.2 Dampproofing

For below grade installations, CONFORM formwork provides dampproofing for the concrete wall. A concrete wall with CONFORM was tested to resist water penetration under hydrostatic pressure.

4.4.7 Foam Plastic Insulation

IBC 2603.3 Surface Burning Characteristics

The polyurethane foam in CONFORM CF8i formwork, tested in accordance with ASTM E84, indicated that FSI is not more than 25 and SDI is not more than 450.

IBC 2603.4 Thermal Barrier

The polyurethane foam in CONFORM CF8i formwork is separated from the interior of the building by the 6" concrete wall which meets the requirements of ASTM E119 (CAN/ULC-S101) for a 15 minute fire rating.

If the insulated face of the CONFORM CF8i formwork is exposed to an adjacent space in a building, for example an insulated exterior wall face extending below a low roof, it must be protected by an approved thermal barrier of ½" gypsum wallboard on light gauge steel framing or by another equivalent thermal barrier.

IBC 2603.5 Exterior Walls of Buildings of Any Height

Exterior walls with insulated CONFORM CF8i formwork comply with the requirements for Types I, II, III and IV construction.

IBC 2603.5.1 Fire-Resistance Rated Walls

A load bearing concrete wall with CONFORM CF6 formwork, tested in conformance with ASTM E119 (CAN/ULC-S101), met the requirements for a 2 hr fire rating.

Based on a ASTM E119 (CAN/ULC-S101) test, fire consultant, Locke MacKinnon Domingo Gibson & Associates Ltd. (LMDG) determine that walls with CONFORM CF8i formwork meet the requirements for a 2 hr fire rating.

IBC 2603.5.2 Thermal Barrier

The exterior insulation in CONFORM CF8i formwork is separated from the interior of the building by the cast-in-place concrete and meets the requirements of ASTM E119 (CAN/ULC-S101) for a 15 minute fire rating.

IBC 2603.5.3 Potential Heat

The polyurethane foam in CONFORM CF8i formwork was tested in conformance with NFPA 259 and meets the requirements of this section.

IBC 2603.5.4 Flame Spread and Smoke-Developed Indexes

The polymer facing and the polyurethane foam in CONFORM CF8i formwork tested in accordance with ASTM E84 indicated that FSI is not more than 25 and Smoke Developed Index SDI is not more than 450.

IBC 2603.5.5 Test Standard

A concrete wall with the insulated CONFORM CF8i formwork was tested in accordance with NFPA 285 and complies with the acceptance criteria.

IBC 2603.5.6 Label Required

The components of CONFORM CF8i formwork are labeled in compliance with this section.

IBC 2603.5.7 Ignition

CONFORM CF8i formwork was tested in accordance with NFPA 268 and complies with the acceptance criteria.

4.4.8 Structural Requirements

IBC 1901.2 Plain and Reinforced Concrete

Cast-in-place, structural concrete walls constructed using CONFORM formwork shall be designed in accordance with Chapter 19 and ACI 318 "Building Code Requirements for Structural Concrete" and by a Professional Engineer skilled in such designs and licensed to practice under the appropriate legislation.

4.5 International Residential Code

Since the requirements of the International Residential Code are similar to the IBC, CONFORM complies with the requirements of the appropriate sections of the IRC code.

4.6 Florida Building Code

The requirements of the Florida Building Code - Building and the Florida Building Code - Residential, are similar to the IBC and IRC. CONFORM complies with the requirements of the appropriate sections of the Florida codes. CONFORM is listed under **Florida Product Approval No. FL 15207**.

4.7 Third Party Evaluations

CONFORM has been reviewed and evaluated for conformance to the requirements of building codes and other authorities, by several Independent Third Party Agencies.

4.7.1 NBC and OBC

Code consultants, Leber Rubes Inc., and Randall Brown Associates Ltd., evaluated and confirmed that CONFORM complies with the National Building Code of Canada 2005 and the Ontario Building Code 2006.

4.7.2 OBC

Ontario Building Materials and Evaluation Commission (BMEC) reviewed and confirmed that CONFORM complies with the OBC 2006 for non-combustible construction and that the webs comply with Article 3.1.5.2 and demonstrate compliance with the requirement for minor combustible components.

4.7.3 IBC and IRC

ICC Evaluation Services Inc. evaluated and validated that CONFORM complies with the International Building Code 2009, the International Residential Code 2009, and the Florida Building Code 2010 - Building and Residential, as per **ICC-ES Evaluation Report ESR-1223**.

4.7.4 IBC and IRC

Code consultant, Leber Rubes Inc., evaluated and confirmed that CONFORM complies with the International Building Code 2009 and the International Residential Code 2009.

4.7.5 CFIA

Canadian Food Inspection Agency evaluated and confirmed that CONFORM complies with the requirements for use in food plants, as per **CFIA Report N251**.

4.7.6 FEMA

Texas Tech University, Wind Science and Engineering Research Center, tested and confirmed, in 2001, that CONFORM complies with the criteria as established by FEMA #320 "Taking Shelter from the Storm".

4.7.7 LEED & GBI

UL Environment evaluates and validates that CONFORM contains a minimum 55% recycled content and is mold resistant per ASTM G21 and C1338, as per **ULE Product Number 11030001**.

4.7.8 Quality Assurance

INTERTEK NA reviews and validates the ongoing Quality Assurance program for CONFORM, on a quarterly basis, as part of the ICC-ES Evaluation. On a continuing basis, CONFORM undergoes numerous quality checks to ensure that the material and product will be acceptable for use.

4.8 Technical Publications

The performance of CONFORM, previously Royal Building Systems, has been reviewed and evaluated for several technical aspects.

4.8.1 Seismic Performance

A report by Dr. D. Tso, Professor of Civil Engineering, McMaster University, 1997 - Based on testing and evaluation of two sample structures for a six-storey building, the report concludes that walls with Royal Building Systems (RBS) offers better seismic resistance. Walls with RBS were reported as stronger and stiffer in the elastic range and the rate of deterioration was less severe in the inelastic range. Walls with RBS were found to be more than adequate to satisfy the Chinese earthquake regulations and suitable for construction in seismic intensity 8 degree regions of China.

4.8.2 Blast Performance

A technical paper presented at International Symposium on Interaction of the Effects of Munitions with Structures (ISIEMS), 2007 - "Blast Response of Stay-in-Place Formwork Walls" authored by J. Davidson, J. Fisher and R. Dinan presented a summary of the tests on CONFORM by Air Force Research Laboratory (AFRL) Tyndall AFB, Florida. The paper concludes that the PVC forms provide significant blast protection compared to walls without the polymer constituents and that the PVC forms capture concrete spalling and wall fragments when subjected to shock loading.

4.8.3 Blast Performance

A published article in The Military Engineer, May/June 2008 - "Utilizing COTS Products for AT/FP", co-authored by Ret. Lt. Col. Charles Minter USAF and by Les Holroyd, P. Eng., outlines the benefits of CONFORM as a commercial-off-the-shelf product ready for Anti-Terrorism and Force Protection Applications.

4.8.4 Thermal Performance

A technical report by Trow Consulting Engineers, 1999 - The report co-authored by Dr. Eric Burnett, Director, Pennsylvania Housing Research Center summarizes the thermal mass benefits of Royal Building System.

4.8.5 Innovative Building System

A technical paper presented at the International Builders Show in Atlanta, 2001 - The paper Penn State Research Report No. 74, 2001 discusses the advantages of Royal Building Systems.

4.8.6 Foundation Wall

A technical report, Penn State Research Report No. 51, 1998 - The report ranked the RBS8i Wall System as the best foundation wall system out of eight different foundation walls that were evaluated.

4.8.7 Placement and Consolidation of Concrete within RBS Walls

A technical report by Trow Consulting Engineers, 2001 - The report concludes that the RBS placing method and a rate of 5 metres per minute, can achieve a dense, homogeneous concrete structure in a wall height of 10 metres, without significant voids and honey combing.

4.9 Past Evaluations

Since 1992, CONFORM, previously Royal Building Systems™, has been reviewed and evaluated by numerous code authorities and testing agencies. Many past evaluations are discontinued but may be relevant to past projects and current applications. In all cases, CONFORM was accepted and complied with the requirements of the applicable regulatory agency:

- Royal Building Systems - CCMC, Evaluation Report 12536-R
- Royal Building Systems - Ontario Ruling of the Ontario Minister of Municipal Affairs and Housing, No 95-01-20-(12536-R)
- Royal Building Systems - BMEC, Report #98-05-228
- Royal Building Systems - Ontario Building Code Commission, Ruling 97-07-549, Ruling 97-45-587 and Ruling 03-25-923
- Royal Building Systems - CSA Certificate, No. 1087266 (LR 78390-1), Non-Metallic Electrical Raceway (CSA and UL)
- Royal Building Systems - BOCA, Report 94-57 and Report 98-40
- Royal Building Systems - ICBO, Report ER 5174
- Royal Building Systems - ICC, Legacy Report ER-5174 and Report 98-40
- Royal Building Systems - Florida Building Codes and Standards, Florida Product Approval FL-7382
- Royal Building Systems - Accepted for construction in numerous countries around the world such as Russia, Japan, China, Poland, Argentina, Columbia, Philippines, Caribbean nations and others

5. Product Performance

5.1 Material Performance

CONFORM® is a result of many years of research and development. Considerable testing has been conducted both "in-house" and through third parties. NUFORM® has retained the services of several independent, accredited, testing laboratories, technical experts and product evaluation agencies to conduct numerous testing programs on various aspects of CONFORM and to prepare engineering and evaluation reports. The physical properties of the polymer material and the CONFORM components are outlined in Section 2 of this guide.

CONFORM components are manufactured using a polyvinyl chloride, polymer material and there are many inherent advantages in the product. The manufacturing process is a high quality, co-extrusion process that creates fused layers of material which do not peel, flake or delaminate and provide a consistent appearance and performance. The outer surface is a UV-protected, virgin capstock that resist degradation. The inner substrate is composed of post-industrial, recycled, waste material that is blended with an additive package to meet the product specifications. This combination provides CONFORM components with a durable, graffiti resistant, low maintenance finish combined with a "green" recycled substrate.

5.2 Structural Performance of Concrete Walls with CONFORM®

CONFORM is composed of cored box connector and panel components that provide stay-in-place formwork for cast-in-place, concrete walls and provide a permanent finish for the walls. The polymer components have cored inner webs that allow construction of monolithic concrete walls. The concrete can be reinforced, as required by the engineering design, with steel bars, that are installed inside the formwork, prior to placing the concrete.

The concrete walls are designed in accordance the applicable building codes and standards. In Canada, the concrete design standard is CAN/CSA A23.3, Design of Concrete Structures and in the USA, the design standard is ACI 318, Building Code Requirements for Structural Concrete. The walls can be designed using the applicable methods for either plain concrete or steel reinforced concrete. The design approach along with detailed information of the physical properties are provided in the CONFORM Engineering Guide.

Testing of concrete walls with CONFORM has been conducted in many countries around the world including Canada, USA, Argentina, Japan, and China for local approvals and performance evaluation. Based on the testing, NUFORM has demonstrated that walls with CONFORM meet the applicable building code requirements and perform well under extreme conditions, such as high seismic activity, excessive winds and blast events. Technical reports for these extreme conditions are noted in Sections 4.7 and 4.8 of this guide.

5.3 Fire Performance

Concrete walls with CONFORM are composed of three elements:

- The walls have a structural base of non-combustible concrete with permissible minor combustible components, in accordance with NBC clause 3.1.5.2 and IBC clause 703.4.2 .
- The walls have a permanent exterior finish as permitted in non-combustible construction, in accordance with NBC clause 3.1.5.5 and IBC clause 2603.5.5.
- The walls have a permanent interior finish as permitted in non-combustible construction, in accordance with NBC clause 3.1.12.1 and IBC clause 803.1.1.

Each of the above elements has been tested separately and combined, to ensure that the walls are in compliance with the building codes.

The fire properties of the coextruded polymer material used for CONFORM, known as Royalloy B, has been tested to numerous ASTM standards. The fire properties of Royalloy B, can be found in Table 5.1 which indicates the test method and the test result.

The fire performance of CONFORM as the permanent interior wall finish has been tested to the applicable CAN/ULC S102.2 and ASTM E84, Standard Method of test for Surface Burning Characteristics of Building Materials. CONFORM is acceptable for all types of building construction with the exception of return air plenums and some locations of high buildings. The interior finish is classified as a Class A finish as per IBC Section 803.1.1. The fire performance results for the surface burning tests are noted in Table 5.2.

Table 5.1 Fire Properties of Royalloy B - Combustion₍₄₎

Fire Performance	Test Method	Requirement	CONFORM Results
Self-ignition temperature	ASTM D1929	min 343 °C 650 °F	480 °C 896 °F
Flash-ignition temperature	ASTM D1929	none none	460 °C 860 °F
Rate of burn	ASTM D635	max 100 mm/10 sec 4.0 in/10 sec	0.0 mm 0.0 in
Maximum extent of burning	ASTM D635	max 25.4 mm 1.0 in	12.4 mm 0.49 in
Ash content	ASTM D229	report value	28%

Table 5.2: Fire Properties of Royalloy B - Surface Burning₍₄₎

Fire Performance	Test Method	Code Requirement	CONFORM Results ₍₅₎
Flame spread	ASTM E84 ULC S102.2	max 25 < 150	≤ 25 (20) ≤ 25 (5)
Smoke development	ASTM E84 ULC S102.2	max 450 report value	≤ 450 (400) ≤ 350 (190)

(4) The numerical fire ratings and test results set out herein, are not intended to reflect hazards presented by any Nuform Building Technologies Inc. products, including CONFORM, under actual fire conditions. These ratings are determined by small scale tests conducted by independent testing facilities using the CAN/ULC or ASTM test standard. NUFORM provides these results for product comparison purposes only. Like other combustible materials (e.g. wood), CONFORM made of polyvinyl chloride (PVC) will burn but only when exposed to an external heat source. When ignited, PVC may produce dense smoke which may be toxic. Proper fire safety considerations, require proper design of a facility and the fire suppression systems used, as well as necessary precautions during construction and occupancy. Local codes, insurance requirements and any special needs of the product user, will determine the correct fire rating and fire suppressions system necessary for a specific installation.

(5) The indicated test results are based of numerous tests and the test result for one specific test is noted in brackets.

The fire resistance rating of the concrete wall, inside the CONFORM formwork, is not significantly affected by the polymer webs. Testing has been conducted on a load bearing concrete wall, in accordance with CAN/ULC S101, (ASTM E119 equivalent), Standard Methods of Fire Endurance Tests of Building Construction and Material. Based on this test, and the reviews by several fire consultants, the fire resistance ratings of the concrete walls, as shown in Table 5.3, have been determined. In addition, the results showed compliance to the 15-minute remain-in-place test that is required for fire protection between the exterior foam insulation of the CF8i components and the interior occupied space.

Table 5.3: Fire Resistance of Walls with CONFORM⁽⁶⁾

CONFORM	Overall Thickness	Nominal Concrete Core Thickness	Minimum Fire Resistance
CF4	100 mm (4")	95 mm (3.74")	45 minutes
CF6	150 mm (6")	145 mm (5.71")	2 hours
CF8	200 mm (8")	195 mm (7.68")	2 hours
CF8i	200 mm (8")	140 mm (5.51")	2 hours

The fire performance rating of CONFORM as a permanent exterior wall finish, both with and without insulation, has been tested to the applicable building code standards. The wall finish was tested and met the requirements of CAN/ULC S134, Standard Method of Fire Test of Exterior Wall Assemblies. This test method, in accordance with the NBC code, provides an assessment of fire spread, vertically and horizontally on the exterior face of exterior wall assemblies. The exterior wall finish is evaluated from fire exposure resulting from a fire compartment venting through an opening in the wall. A similar test NFPA 285, Standard Method of Test of the Evaluation of Flammability Characteristics of Exterior Wall Assemblies with Combustible Components, was also conducted. This test method in conjunction with NFPA 259 and NFPA 268 evaluated and confirmed compliance of the exterior finish for fire exposure, in accordance with the IBC code.

Refer to Section 4.0 for a full listing of the applicable fire requirements of the Canadian and USA building codes.

5.4 Sustainability of CONFORM

NUFORM and the plastics industry are committed to providing "green" building products. By providing environment friendly building products, NUFORM promotes the conservation of resources and reduces the environmental impact of buildings. At the core of NUFORM's commitment is the manufacturing process, "R3 Sustainable Technology". NUFORM has over 15 years of proven performance, using recycling process technology. CONFORM is manufactured using post-industrial (pre-consumer), recycled waste material that is blended with a specific additive package. Individual components may contain up to 75% outsourced recycled material but in addition, all internal scrap is reprocessed in the components. Therefore, NUFORM makes a claim that a minimum 55% outsourced recycled material is used in the manufacturing of CONFORM. The environmental commitment at NUFORM™ is so strong, that UL Environment is retained to provide a third party audit and validation of the recycled content claim as noted in the Environmental Claims Validation (ECV) issued by ULE.section 4.7.7.

The finished CONFORM components are highly mold and mildew resistant (as per ASTM G21). The high quality, durable, smooth surface finish required minimal maintenance and has negligible VOC emissions leading to healthier interior environments. The excellent light reflectivity promotes lower lighting requirements and lower building energy costs. The pre-finished surface, eliminates all painting and finishing thereby minimizing the use of more hazardous products during manufacturing and on-site finishing and painting.

These properties and others of CONFORM can be used in LEED or GBI assessments and provide contributions to a significant number of points. A list of the contributions by CONFORM that may be considered in a LEED-NC assessment is provided in Table 5.4.

(6) The indicated values are based on Engineering study and a Fire Endurance Test on a concrete wall with CONFORM CF6. The fire rating test was conducted at Underwriters Laboratory of Canada (ULC), on a load bearing wall, 619.6 kN/m (42.5 kips/ft), with vertical and horizontal reinforcing steel, 10M @ 333 mm o/c, each way at centerline (#4 at 13" o/c).

Table 5.4: Potential CONFORM LEED® Contributions

LEED Credit(s) Number	LEED Credit(s) Name	CONFORM Contribution
SS Credit 5.1 1 point available	Site Development - Protect or Restore Habitat	- Less site space due to less scrap storage, due to interior bracing; due to less exterior cladding and finishes
EA Credit 1 10 points available	Energy and Atmosphere - Optimize Energy Performance	- High Thermal Mass rating facilitates compliance with ASHRAE 90.1 by reducing building energy demand - High reflectivity and off-white color helps reduce lighting energy demand - Low air leakage reduces HVAC energy demands
MR Credit 2 2 points available	Materials and Resources - Construction Waste Management - Divert 50% from Disposal Divert 75% from Disposal	- Pre-fabricated components to suit specific building requirements results in no construction waste - Pre-engineering to suit specific building requirements results in minimal spare components on site - Spare components can be re-used for other buildings
MR Credit 4 2 points available	Materials and Resources - Recycled Content - 10% (post-consumer + 1/2 pre-consumer 20% (post consumer + 1/2 pre-consumer)	- CONFORM is manufactured from up to 80% pre-consumer recycled material that is waste from other vinyl manufactured products - Concrete used in the CONFORM formwork can be manufactured using recycled aggregates and/or recycled flyash
MR Credit 5 2 points available	Materials and Resources - Regional Materials - 10% Extracted, Processed & Manufactured regionally 20% Extracted, Processed & Manufactured regionally	- CONFORM is manufactured in Toronto and is within 500 miles of most of the northern USA - Concrete used in the CONFORM formwork is manufactured locally and uses local aggregates
IEQ Credit 4.1 1 point available	Indoor Environmental Quality - Low-Emitting Materials - Adhesives & Sealants	- Low VOC - No adhesives and minimal sealants required
IEQ Credit 4.2 1 point available	Indoor Environmental Quality - Low-Emitting Materials - Paints & Coatings	- Low VOC - No paints or coatings required
IEQ Credit 7.1 1 point available	Thermal Comfort - Design	- High Thermal Mass reduces temperature variations - Low air leakage reduces drafts
ID Credit 1 5 points available	Innovation & Design - innovation & Design	- CONFORM is durable, multi-functional product - Low maintenance

5.5 Energy Performance

Three major factors affecting the thermal performance of a wall system are **thermal bridging**, **air tightness** of the enclosure and **thermal mass**. Until recently, the combined effect of these factors has not been considered when comparing the thermal performance of a building system and a simple R-value was used. However, studies showed that the simple comparison of R-values is not an appropriate method of comparing the thermal performance of different building systems. Consequently, revised energy codes were developed such as 2007 ASHRAE 90.1, 2011 National Energy Code for Building (NECB) and 2009 International

Energy Conservation Code (IECC). These code include requirements, both prescriptive and performance based, that take into account thermal bridging, air leakage and thermal mass.

NUFORM was a leader in recognizing the need to consider all three of these aspects of wall construction. In 1999, Trow Consulting Engineers Ltd was commissioned to provide a detailed study of the thermal performance and benefits of walls with CONFORM. The report was co-authored by Dr. Eric Burnett, Director, Pennsylvania Housing Research Center and a summary of the thermal mass benefits of CONFORM (Royal Building System) are summarized in Table 5.5.

Table 5.5: Mass Benefits of Walls with CONFORM in Various Climates⁽⁷⁾

City	ORNL Estimated Equivalent R-Value for:			
	R11.9 Walls ¹ (RSI 2.10 or U = 0.477)	R14.3 Walls ² (RSI 2.52 or U = 0.397)	R16.9 Walls ³ (RSI 2.98 or U = 0.336)	R19.4 Walls ⁴ (RSI 3.42 or U = 0.293)
	CF4, CF6, or CF8 + 2" EXP	CF4, CF6, or CF8 + 2 1/2" EXP or CF8i	CF4, CF6, or CF8 + 3" EXP	CF4, CF6, or CF8 + 3 1/2" EXP
Atlanta	R25.1 (RSI 4.42 or U =0.226)	R30.2 (RSI 5.32 or U=0.188)	R36.3 (RSI 6.39 or U=0.156)	R41.7 (RSI 7.34 or U=0.136)
Denver	R22.4 (RSI 3.94 or U=0.253)	R26.9 (RSI 4.74 or U=0.211)	R31.3 (RSI 5.51 or U=0.181)	R35.9 (RSI 6.32 or U=0.158)
Miami	R26.2 (RSI 4.61 or U =0.217)	R31.5 (RSI 5.55 or U=0.180)	R41.2 (RSI 7.25 or U=0.138)	R47.3 (RSI 8.33 or U=0.120)
Minneapolis (similar to Toronto)	R17.7 (RSI 3.11 or U =0.321)	R21.3 (RSI 3.75 or U=0.267)	R24.8 (RSI 4.37 or U=0.229)	R28.5 (RSI 5.01 or U=0.199)
Phoenix	R30.6 (RSI 5.39 or U =0.186)	R36.8 (RSI 6.48 or U=0.154)	R41.6 (RSI 7.33 or U=0.136)	R47.7 (RSI 8.40 or U=0.119)
Washington (similar to Vancouver)	R21.4 (RSI 3.77 or U =0.265)	R25.7 (RSI 4.53 or U=0.221)	R30.9 (RSI 5.44 or U=0.184)	R35.5 (RSI 6.25 or U=0.160)

R = thermal resistance [ft² · hr · °F/Btu]

RSI = thermal resistance [m² · k/W]

U = thermal conductance [W/(m² · K)]

1. The ORNL values are based on a wall with 1/2" drywall, 4" of solid concrete, and R12 exterior insulation (total R-value of 13.0). The equivalent CF4, CF6, and CF8 formed walls with 2" (steady-state R11.9) of extruded polystyrene sheathing have slightly less exterior insulation and the same or slightly more thermal mass.
2. These values have been interpolated from the ORNL values of R13 and R17.2 walls. The equivalent CF4, CF6, and CF8 formed walls with 2 1/2" (steady-state R14.3) of extruded polystyrene sheathing or CF8i walls with 2 1/8" of integrated polyurethane insulation, have slightly more or less exterior insulation and thermal mass.

3. The ORNL values are based on a wall with 1/2" drywall, 6" of solid concrete, and R16 exterior insulation. The equivalent CF4, CF6, and CF8 formed walls with 3" of extruded polystyrene sheathing (R16.9) have slightly more exterior insulation and the same or slightly less thermal mass.

4. These values have been interpolated from the ORNL values of R13 and R17.2 walls. The equivalent CF4, CF6, and CF8 formed walls with 3 1/2" (steady-state R19.4) of extruded polystyrene sheathing have slightly more exterior insulation and the same or slightly less thermal mass.

(7) Trow Consulting Engineers Ltd Report T99-01 Rev 1 Dated Aug 30,1999. Based on research by Oak Ridge National Laboratory (ORNL). Researchers at ORNL investigated the effect of thermal mass on annual energy consumption in a range of U.S. climates. Employing the same representative, one-story ranch-type house, the ORNL researchers modeled the space-conditioning energy consumption over a typical year for houses with both lightweight and massive walls. The base house in all cases had a lightweight roof assembly insulated to R30. The contribution of air leakage was assumed to be the same for all homes.

Thermal bridging is caused by wood or steel members, especially in light-frame construction. These members act as a thermal bridge causing heat flow to short circuit. Unlike walls with CONFORM, framed systems can suffer from severe thermal bridging and heat loss especially at corners, windows and partitions (see Figure 5.6). For instance, a 2" x 6" wood framed wall with a drywall interior finish and vinyl siding can be shown to have a nominal R-value of 21.5 (RSI 3.79), using R19 batt insulation. When the thermal bridging inherent in framing around doors and windows is taken into account, ASHRAE considers such a wall to have an R-value of 13.7 (RSI 2.41). Therefore, a 2" x 6" wall system would not meet the requirements of the ASHRAE standard for residential buildings in colder regions, such as Michigan or North Dakota, without additional continuous insulation over the studs, as now prescribed by the energy codes.

Air leakage through the building enclosure can be a major source of energy loss, approximately 30% to 50%. Air tight buildings lose far less energy through the building envelope. Compared to many conventional building methods, walls with CONFORM provides a tighter building envelope, without the use

of an additional air barrier. For instance, a 4" concrete wall with CONFORM CF4 formwork has an air leakage rate of 0.020 L/(s • m²) (0.0039 ft³/(min • ft²)) at a pressure differential of 75 Pa (1.57 psf). This is the same level of air tightness required from a 6-mil thick sheet of polyethylene when used as an air barrier.

Thermal mass effect is provided by thermal insulation applied to the exterior of the concrete wall. This thermal mass effect provides for significantly lower energy consumption when compared to lightweight wall systems with the same nominal R-Value. In some climates, the effective R-value of a wall with CONFORM will be twice that of a framed wall insulated to the same nominal level. The R-value of exterior insulation added to a concrete wall with CONFORM CF4, CF6 and CF8 can be based on prescriptive code requirements or determined by a performance approach. The exterior insulation provided by the insulated CONFORM CF8i formwork has a R-value of 13.3, but the thermal mass effect increases the effective R-value.

Figure 5.6

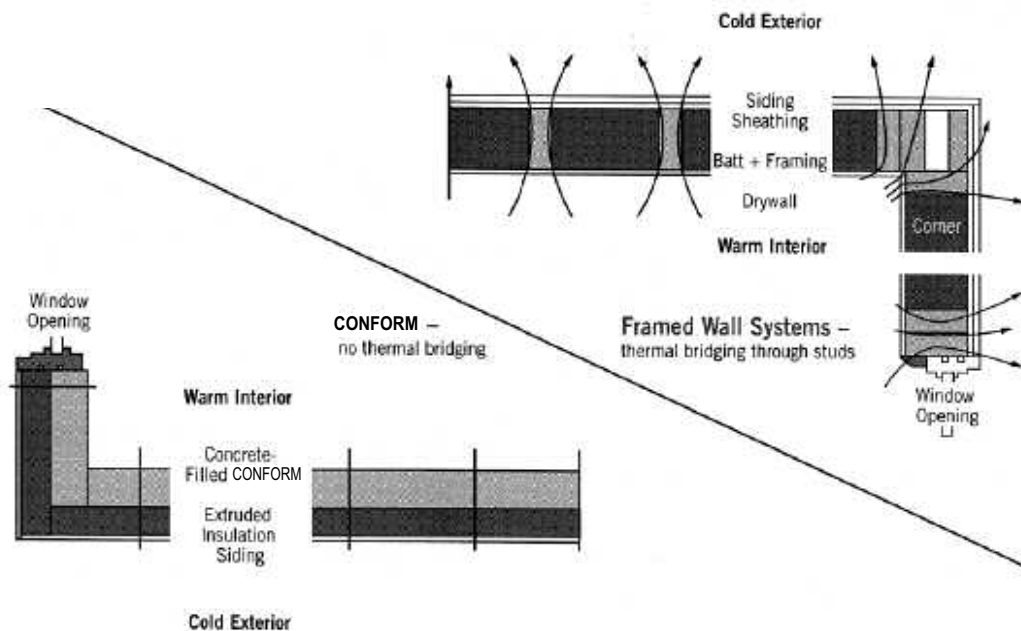

5.6 Vapor and Air Barriers

When filled with concrete, CONFORM acts as a vapour and an air barrier. The two 0.100" thick polymer faces of CONFORM act as the vapor barrier and are more durable than the typical 0.006" thick sheet of polyethylene used in conventional construction. When tested, a 4" concrete wall with CF4 showed an air leakage rate of 0.020 L/(s · m²) (0.0039 ft³/(min · ft²)) at a pressure differential of 75 Pa⁽⁸⁾ (1.57 psf). Consequently, additional air and vapor barriers are not required when using CONFORM.

5.7 Water Penetration

Tests have been conducted to determine the water resistance of concrete walls with CONFORM.

For above-grade use, water penetration testing was conducted in accordance with ASTM E547⁽⁹⁾ using a pressure differential up to 700 Pa (14.6 psf) across the wall and in accordance with ASTM E331⁽¹⁰⁾ using a pressure differential of 300 Pa (6.24 psf) across a sealed opening. It was established that concrete walls with CONFORM are watertight without the use of additional cladding.

In addition, for below-grade or basement use, a wall with CF8i was tested under a 5-foot column of water. During the 24-hour test period no water infiltrated the interior face of the wall. For complete test results, please refer to Trow report dated August 26, 1997. The testing established that basement concrete walls with CONFORM does not require additional damp-proofing on the outside, when used below-grade, if built in accordance with the recommended procedures.

5.8 Indoor Air Quality (IAQ)

In recent years, Indoor Air Quality (IAQ) has become a serious concern, especially due to Volatile Organic Compounds (VOC's) and mold growth in houses and schools. The resulting poor IAQ has serious health implications. Epidemiological studies from the U.K., the Netherlands, Sweden and Canada have consistently shown negative health effects associated with dampness and mold. In children, symptoms most

commonly associated with mold include respiratory problems, aches and pains, diarrhea and headaches. In adults, the symptoms can include aching joints, nausea and vomiting, backache, blocked nose and breathlessness.

As discussed in the following subsections, CONFORM does not contribute to poor IAQ, but further enhances the IAQ by providing a wall surface that does not off-gas and that is mold and mildew resistant.

5.8.1 Volatile Organic Compounds (VOC's)

Testing and chamber studies⁽¹¹⁾ have been conducted to assess the Indoor Air Quality of homes using CONFORM⁽¹²⁾. The objective was to assess the contribution of volatile organic compounds (VOC), or "off-gassing", associated with the extruded PVC building components to the concentration of the total VOC (TVOC) found in the indoor air.

Based on the testing and analysis, the following was concluded:

- The average TVOC concentration found in three model homes tested for IAQ was less than 0.3 mg/m³. This is significantly less than 1.0 – 2.0 mg/m³ typically found in occupied houses and offices.
- Chamber studies indicated that in the worst-case scenario (a house built using CONFORM and occupied only one month after the building components were extruded – representing the maximum amount of off-gassing from the new material), the concentration of 0.04 mg/L (mg/m³) would contribute less than 15% to the TVOC found in the model homes. Note that the concentration of 0.04 mg/m³ is reaching the limit of analytical detection.
- The "off-gassing" from the extruded CONFORM components is significantly less than the off-gassing associated with conventional building products such as: natural wood, laminated wood, particle board, various walls covering, etc.

No health hazards or discomfort has been associated with the TVOC levels found in the three model homes tested for IAQ.

(8) See Trow Report No T93-24, dated October 29, 1993.

(9) See Trow Report No T93-25, dated November 12, 1993.

(10) See Intertek Report No 3077903-1, dated January 27, 2006.

(11) Chamber testing of the extruded CONFORM components was conducted in June 1997. For a complete report, please refer to Alara Report #9736, dated August 18, 1997

(12) Indoor air-quality tests were conducted in January, 1997. For more details, please refer to Alara Report #9701, dated February 11, 1997.

5.8.2 Mold Resistance

The growth of biological pests is assisted and promoted by wet building materials such as gypsum wallboard and wood. These conventional building materials get wet through absorption of water from high indoor humidity, condensation caused by thermal bridging, moist air leaking through the building envelope, or simply by rain/ground water penetrating the interior of the building.

CONFORM does not promote or allow the growth of mold and mildew as moisture does not penetrate the interior, and because the polymer surface does not absorb and store moisture. Even high indoor humidity levels will not damage the interior face of the walls, as the polymer surface is moisture resistant and vapor impervious. Testing has been conducted by Underwriters Laboratories to confirm that the polymer and polyurethane insulation of CONFORM, are mold resistant as per ASTM E21 and ASTM C1338.

5.9 Acoustic Performance

Almost all building codes require that walls separating dwelling units from each other or from public or service areas have a Sound Transmission Class (STC) of not less than 50 (or 45 if field tested). STC is established in accordance with ASTM E90, *Standard Test Method for Laboratory Measurement of Airborne Sound Transmission Loss of Building Partitions and Elements*. Whereas field testing is conducted in accordance with ASTM E336, *Standard Test Method for Measurement of Airborne Sound Insulation in Buildings*.

The acoustic testing of the concrete walls with CONFORM was conducted in accordance with ASTM E336. Based on this testing, the sound transmission of concrete-filled CONFORM is summarized in Table 5.7. A FSTC rating of 45 is considered equivalent to an STC rating of 50.

Table 5.7 Sound Transmission Rating of Concrete Walls with CONFORM

CONFORM	Overall Thickness	FSTC Rating	STC Rating
CF4	100 mm (4")	48	52
CF6	150 mm (6")	47	52
CF8	200 mm (8")	50	55
CF8i	200 mm (8")	53	58

5.10 Longevity and Weatherability

The polymer used for CONFORM, Royalloy B, has been specifically designed to resist fading and discoloration due to weathering, due to a highly UV resistant outer capstock layer.

Accelerated Weathering Tests (Table 5.8) were conducted in accordance with ASTM D4329 and ASTM G53 for 2000 hours. Physical Outdoor Weathering Tests (Tables 5.9 – 5.11) were conducted in accordance with ASTM D4216 and ASTM D1435, for 2 years.

Table 5.8: Weathering Properties of Royalloy B – Accelerated⁽¹³⁾

Property	Units	ASTM Test Method	Results
Yellowness Index	ΔYI	D1925	+ 2.15
Color Retention (Hunter Units)	ΔE	D2244	+ 0.98
	ΔL	D2244	- 0.34
	Δa	D2244	+ 0.01
	Δb	D2244	+ 0.92
Drop Dart Impact	% Retention	D4226	97

Table 5.9: Weathering Properties of Royalloy B – Outdoor⁽¹⁴⁾ (Ohio)

Property	Units	ASTM Test Method	Results		
			6 months	1 year	2 years
Yellowness Index	ΔYI	D1925	- 0.10	- 0.20	- 1.51
Color Retention (Hunter Units)	ΔE	D2244	+ 0.39	+ 0.62	+ 0.68
	ΔL	D2244	- 0.37	- 0.60	- 0.24
	Δa	D2244	+ 0.02	- 0.03	- 0.14
	Δb	D2244	- 0.12	- 0.16	- 0.62
Drop Dart Impact	% Retention	D4226	88	95	93

Table 5.10: Weathering Properties of Royalloy B – Outdoor⁽¹⁴⁾ (Arizona)

Property	Units	ASTM Test Method	Results		
			6 months	1 year	2 years
Yellowness Index	ΔYI	D1925	- 0.09	+ 0.10	+ 1.76
Color Retention (Hunter Units)	ΔE	D2244	+ 0.13	+ 0.27	+ 0.81
	ΔL	D2244	- 0.12	- 0.12	- 0.27
	Δa	D2244	- 0.05	- 0.19	- 0.08
	Δb	D2244	- 0.03	+ 0.15	+ 0.76
Drop Dart Impact	% Retention	D4226	86	86	89

Table 5.11: Weathering Properties of Royalloy B – Outdoor⁽¹⁴⁾ (Florida)

Property	Units	ASTM Test Method	Results		
			6 months	1 year	2 years
Yellowness Index	ΔYI	D1925	- 0.22	- 0.43	+ 0.35
Color Retention (Hunter Units)	ΔE	D2244	+ 0.19	+ 0.22	+ 0.36
	ΔL	D2244	- 0.16	- 0.10	- 0.32
	Δa	D2244	- 0.06	- 0.14	- 0.07
	Δb	D2244	- 0.09	- 0.14	- 0.14
Drop Dart Impact	% Retention	D4226	93	100	92

Notes:

- ASTM D1925, - 2° Standard Observer and C Illuminant
- ASTM D2244, - 10 Standard Observer and D65 Illuminant
- ΔYI – change in yellowness index
- ΔE – total color change
- ΔL – change in lightness/ darkness direction
- Δa – change in red/ green direction
- Δb – change in yellow/ blue direction

(13) See Ortech Report 97-553-M0090C dated June 16, 1997

(14) See Cambridge Report 360975-04 (Final) dated October 15, 2007

6. Specifications

The following specification, 03 11 33 Polymer Concrete Formwork, is for the supply and erection of CONFORM® formwork for polymer-encased concrete walls.

An electronic version of this specification and of a specification, 03 47 33 Polymer-Encased Concrete, for the supply and installation of concrete walls with CONFORM, are available in the Technical Section of the NUFORM® website: www.nuformdirect.com

These specifications are general in nature and should be modified to suit the project specific application.

Section 03 11 33- Polymer Concrete Formwork

Part 1 - General

1.1 Description

1. Comply with the General Conditions, Supplementary Conditions and the requirements of Section 01 00 00.

1.2 Work Included

1. Supply and installation of all CONFORM polymer concrete forming components.
2. Design, supply and installation of all bracing for polymer formwork.

1.3 Material Installed but not Specified or Supplied Under This Section

1. Sleeves required by other divisions.
2. Inserts required by other divisions.
3. Anchors required by other divisions.
4. Supply and installation of reinforcing steel for walls.

1.4 Work By Others

1. Supply and installation of cast-in-place concrete for walls.
2. Supply and installation of reinforcing steel dowels in the foundations.
3. Supply and installation of permanent steel framing.
4. Supply and installation of doors and windows.
5. Supply and installation of roof deck and roofing.
6. Supply and installation of wall cap and flashings.

1.5 Related Work Under Other Sections

1. Section 03 20 00 - Concrete Reinforcement
2. Section 03 30 00 - Cast-In-Place Concrete
3. Section 05 10 00 - Structural Steel
4. Section 05 30 00 - Steel Decking
5. Section 07 00 00 - Roofing
6. Section 08 00 00 - Doors & Windows
7. Section 10 00 00 - Sealants and Flashings

1.6 Reference Standards

1. All codes, standard specifications, and by-laws referred to in this section shall be current editions including all latest revisions, addenda and supplements
2. ASTM 4216 - "Standard Specification for Rigid Polyvinyl Chloride (PVC) and Related Plastic Building Products Compounds"
3. CSA S269.3 - "Formwork for Concrete"
(For USA - ACI Committee 347 (SP-4) 318, "*Formwork for Concrete*")

1.7 Design

1. The design loads shall be in accordance with local building codes and standards.
2. Assume full responsibility for the design, for the adequacy, and for the safety of all CONFORM formwork and related falsework for the polymer-encased concrete walls.

1.8 Submittals

1. Submit copy of Manufacturer's Construction Guide.
2. Prepare and submit copies of erection shop drawings in accordance with Section 01 00 00.
3. Shop drawings shall indicate:
 1. Dimensions related to work by others.
 2. CONFORM component locations, types and lengths.
 3. The locations of control joints and expansion joints.
 4. Temporary bracing details.
 5. Openings, sleeves, inserts, and anchors as required by other divisions.
4. Comply with the requirements of Building Authorities and Regulatory Agencies including submission of required shop drawings.
5. Shop drawings and/or calculations shall bear the stamp and signature of the registered Professional Engineer that is responsible for the formwork. The Professional Engineer shall be familiar with the design and construction of concrete walls with CONFORM formwork.

1.9 Quality Assurance

1. Contractor shall engage an installation contractor, (Installer), who has been qualified by the manufacturer for the installation of CONFORM. Alternatively, the contractor shall engage a technical representative, (Technical Advisor), usually a staff member or representative of the manufacturer, who is qualified to instruct and supervise the installation crew on site for the duration of the work under this Section.
2. Installer or Technical Advisor shall furnish proof of qualifications to Architect, prior to commencement of work under this Section.
3. Installer or Technical Advisor shall meet with the contractor prior to material delivery on site to coordinate provisions for access, storage area, and protection of CONFORM material in accordance with the Manufacturer's Construction Guide.
4. Cost of any independent inspection required by the owner to verify compliance with the sections paid by the owner.

1.10 Samples

1. If requested, submit up to 4 samples, 300 mm (12") long, of a box connector, panel and one other component, for each color and wall each wall type, as directed by the Architect.
2. Site Mock-up: If required, construct a sample 1200 mm x 1200 mm (4' x 4') wall mock-up to include full wall system and details, as directed by Architect. Sample wall mock-up may form part of the finished work if approved by Architect.

1.11 Delivery, Storage & Handling

1. Deliver products in good condition, bearing identification of the product and erection label.
2. Handle and store products in location to prevent damaging and soiling.

1.12 Warranty

1. Provide a standard written material and workmanship warranty with duration of one (1) year in accordance with Section 01 00 00.
2. Owner shall contact the Manufacturer for a written copy of specific warranties for CONFORM material.

1.13 Safety Requirements

1. Provide safety cables, harnesses, railings, barricades and other safety equipment and protection where work under this section is in progress and as required by Regulatory Safety Agencies.

Part 2 - Products

2.1 Acceptable Materials

1. All polymer forming materials shall be "CONFORM" materials, only, as manufactured by:

Nuform Building Technologies Inc.
100 Galcat Drive, Unit 2, Woodbridge, Ontario
Canada L4L 0B9
Tel: (905) 652-0001 or Toll-free 1 (877) 747-WALL (9255)
Fax: (905) 652-0002
E-mail: info@nuformdirect.com
Web Page: www.nuformdirect.com

2. CONFORM components shall be manufactured from rigid PVC, polyvinyl chloride, material conforming to Classification 1 211 2332 0040 in accordance with the ASTM 4216.
3. Substitutes and alternates will not be accepted.
4. Provide CONFORM polymer formwork components as listed below or as may be required, for proper execution of the work.
 1. Box connectors - straight, corner, end, 3-way, 4-way, 45° corner
 2. Panels - 232, 182 and 93
 3. Spacers - 68, 49
 4. Other miscellaneous components
5. Provide new material equal in all respects to those specified.

Part 3 - Execution

3.1 Examination

1. Verify that the site conditions, as required by this Section, are as set out in Section 01 00 00 -General Conditions, and in accordance with the Manufacturer's Construction Guide
2. Examine to determine that foundations installed under Section 03 00 00 are within acceptable tolerances of level, dimensions and locations. Refer to clause 3.9 on tolerances.
3. Examine to determine that structural steel installed under Section 05 00 00 is as specified and within acceptable tolerances of specified locations. Refer to clause 3.9 on tolerances.
4. Examine to determine that reinforcing steel dowels are at specified locations and spacing and within acceptable tolerances. Refer to clause 3.5.
5. Report any discrepancies which affect the work of this Section.

3.2 Preparations

1. Clean all dirt and debris from top of footings prior to commencing work.
2. Remove all snow and ice from the top of foundations, prior to placing the polymer formwork components.
3. Before erection is started ensure all dowels, anchors, structural steel and other items are in place.

3.3 Installation

1. Installation of CONFORM shall be performed by an Installer or supervised by a Technical Advisor as required by this Section.
2. Installation shall be in accordance with Manufacturer's Construction Guide as supplied under this Section.

3.4 Service Penetrations

1. Assist and co-ordinate with all trades in the preparation of a drawing showing the type, extent and location of items to be cast in and openings to be formed in the walls. This drawing must be submitted for review and approval prior to factory penalization of walls.
2. Openings shall be cut and sleeves or form-outs provided for service penetrations (e.g. conduits, piping, ductwork etc.) at the required locations as indicated by the shop drawings by the appropriate trades.
3. All openings required by other trades that are not indicated on the shop drawings and that have to be site cut before or after the concrete is poured, shall be done by this section and all costs shall be the responsibility of the appropriate trade.
4. Prior to concrete placement, cut openings and install PVC pipe sleeves or wood formwork, provided by others up to 225 mm square (9" square) at service penetrations to create voids where services can be passed through the wall at a later date.
5. Service penetrations exceeding 225 mm (9") in width or spaced closer than 3 times the diameters on center shall be reinforced as required by project engineer.

3.5 Tolerances

1. Variations from plumb: 6 mm in 3000 mm ($\frac{1}{4}$ " in 10'-0")
2. Variations from plumb in any story or maximum: 13 mm in 6000 mm ($\frac{1}{2}$ " in 20'-0")
3. Variations from level at tops of walls and sills and at head of openings: 6 mm in 3000 mm ($\frac{1}{4}$ " in 10'-0")
4. Variations in the linear building lines from established position in plan and related position to columns or walls by others: 9 mm in any bay of 6000 mm ($\frac{3}{8}$ " in 20'-0") and 13 mm in bays greater than 12,000 mm ($\frac{1}{2}$ " in bays greater than 40'-0")
5. Variations from specified elevation: 19 mm ($\frac{3}{4}$ ") at top of walls and 13 mm ($\frac{1}{2}$ ") at top of sills
6. Variations in sizes of openings: 13 mm ($\frac{1}{2}$ ")

3.6 Clean-Up

1. Upon completion of work, clear away from the building and site any excess or waste materials and debris and leave the premises in a condition acceptable to the Architect.
2. Repair and patch any defective areas of wall face due to blowouts or breaking of webs using material and methods approved by the manufacturer. Patched surface shall be painted with approved paint to match the surrounding wall.

END OF SECTION

Notes

We hope you found this guide informative while designing your project using CONFORM®.

As always, our main goal at Nuform Building Technologies Inc. is to ensure that our valued customers are 100% satisfied with our service and with CONFORM. Should you have any questions or comments, we would like to hear from you. You may contact us at the following:

Please visit the Technical Section of our Web site at www.nuformdirect.com for the latest version of this guide. Please forward us any suggestions or comments for improving this guide. All suggestions for improvements will be given full consideration for future revisions.

PURCHASER IS SOLELY RESPONSIBLE FOR DETERMINING THE SUITABILITY FOR USE OR APPLICATION OF ANY GOODS, INCLUDING COMPONENTS THEREOF, OR WHETHER SUCH GOODS MEET REQUIREMENTS OF APPLICABLE BUILDING CODES OR SAFETY CODES FOR SPECIFIC APPLICATIONS.

© 2012 Nuform Building Technologies Inc. All rights reserved. Reasonable efforts have been made to ensure the accuracy of this publication; however, any information and data contained herein is subject to change without notice.



The Pre-Finished, Stay-in-Place
Concrete Wall Formwork

For more photos and information, visit our Web site at
www.nuformdirect.com



Nuform Building Technologies Inc.
100 Galcat Drive, Unit #2
Woodbridge, Ontario, Canada
L4L 0B9

Toll Free: 1 877-747-WALL (9255)
Tel.: 905-652-0001
Fax: 905-652-0002

PURCHASER IS SOLELY RESPONSIBLE FOR DETERMINING THE SUITABILITY FOR USE OR APPLICATION OF ANY GOODS, INCLUDING COMPONENTS THEREOF, OR WHETHER SUCH GOODS MEET REQUIREMENTS OF APPLICABLE BUILDING CODES OR SAFETY CODES FOR SPECIFIC APPLICATIONS.