

### Overlapping Joints

Joints in F-Trim, J-Trim and H-Trim need to be overlapped a minimum of 1/2".

- Cut and remove a 1" section from the nailing face and the web of the trim as shown in the figures. Only do this to one end of the trim.
- Overlap with next piece of trim. Ensure there is a gap of at least 1/4" at the nailing face to allow for contraction and expansion.

In extremely cold weather, the saw needs to move slowly through the material in order to prevent chipping or cracking.

If possible, perform the cutting in a heated area.

The recommended clearance of 1/4" for contraction and expansion is based on a maximum temperature variation of 72°F (40°C) and lengths not greater than 16' (4.9 m). For recommendations to suit other conditions, please contact Nuform.

Refer to the following figures for a more detailed look at overlapping F-Trim, J-Trim and H-Trim joints.

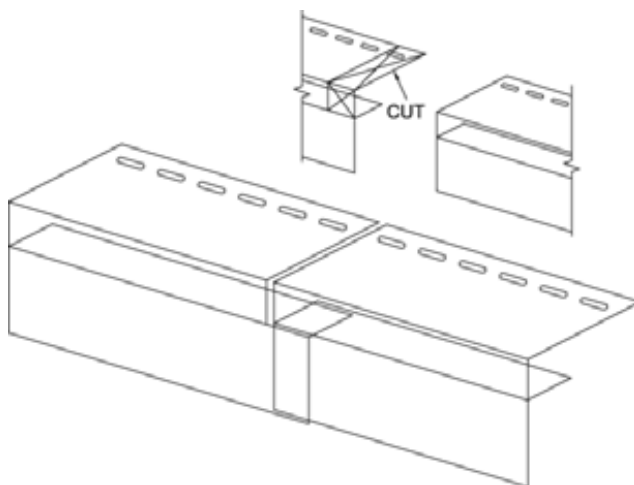

Figure 7 F-Trim Overlap

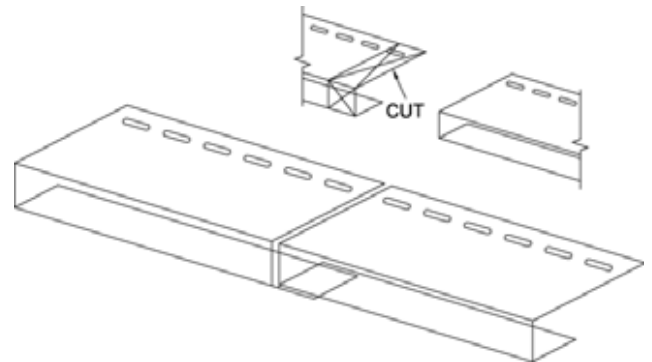

Figure 8 J-Trim Overlap

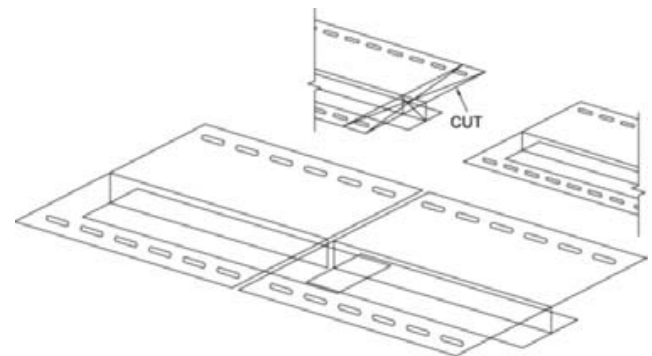

Figure 9 H-Trim Overlap