

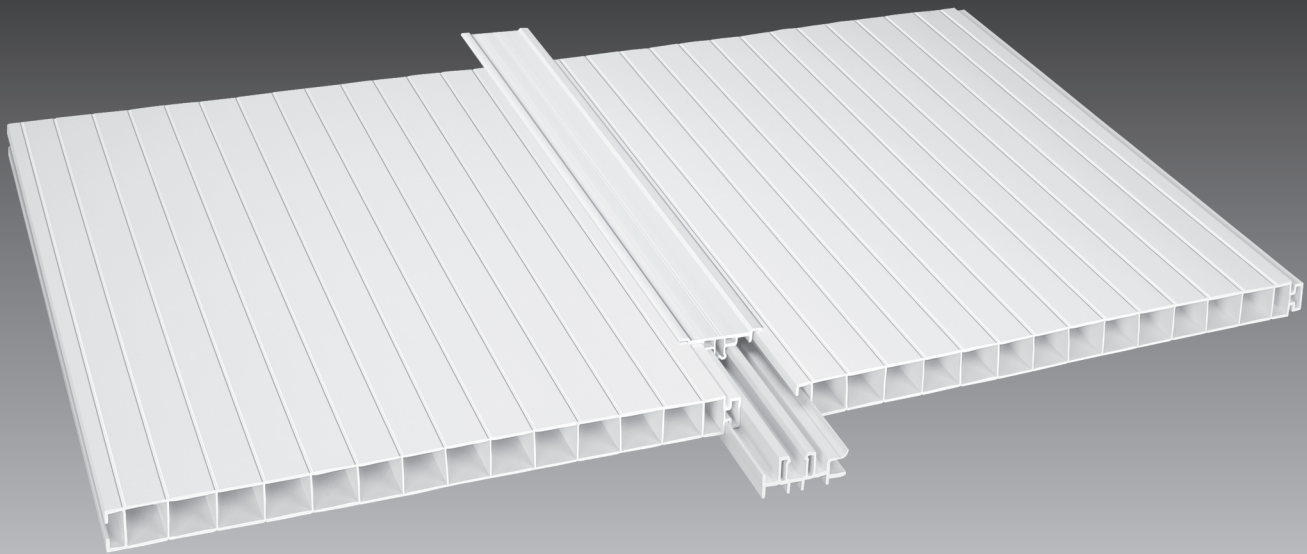

The Power to Renu It!



RENU PANELING SYSTEM

Installation Guide

Version 1.0

PLEASE READ GUIDE
COMPLETELY BEFORE ASSEMBLY.

ALL STATED SIZES ARE NOMINAL DIMENSIONS.

Components

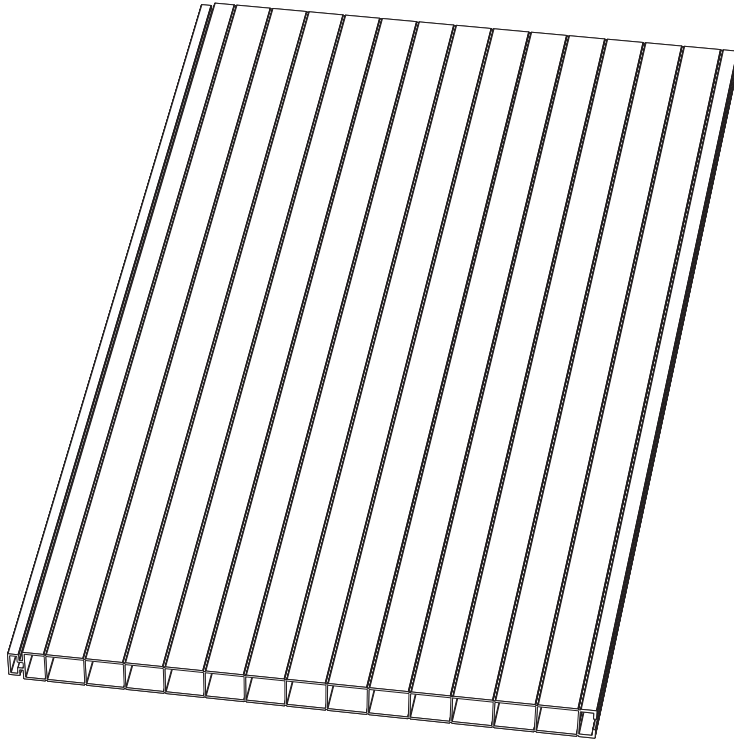

Renu Panel (RP) – 3/4" x 14 5/8" (GER3WPAA): used for walls and ceilings.



Trim Track (TT) – 1" x 1 3/4" (GER3TTAA): fastens to walls and ceilings to hold the Panels in place. **The Trim Track has drainage holes at the bottom to allow proper drainage.**

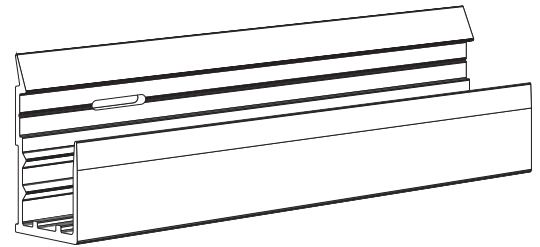

Trim Cap (TC) – 1" x 1 3/4" (GER3TCAA): same component as TT, without the drainage holes at the bottom. The Trim Cap is used as a finishing detail for the Panels, specifically to trim around openings.

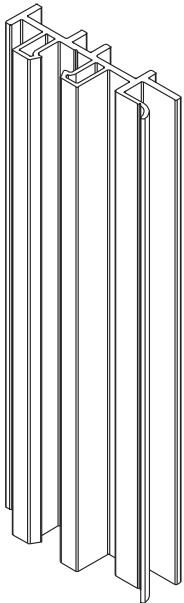

Base Joiner (BJ)
– 3/4" x 2 1/8" (GER3BJAA): fastens to the wall or roof. Connects to either side of the Panels.

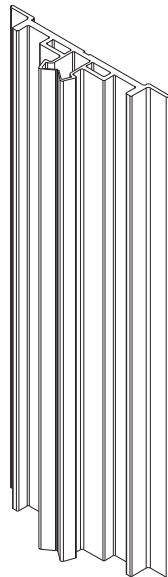

Cap Joiner (CJ)
– 1/4" x 2 1/4" (GER3CJAA): snaps into the Base Joiner and holds the Panels into place.

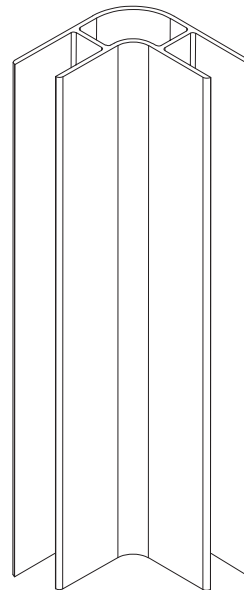

Corner Trim (CN)
– 1" x 3" x 3" (GER3CNAA): used as a 90° inside or outside wall corner. The Corner Trim can also be used at the top of the Panels when installing the Renu Paneling System as a ceiling material.

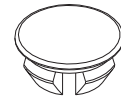

Plastic Plugs (PP) – 3/8" (GER3PPAA): in certain circumstances it might be necessary to fasten a Panel directly onto a wall without using the Base Joiner. The Plastic Plugs are used to cap any holes created in the Panels.

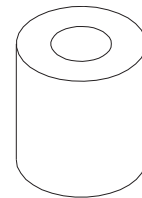

Plastic Spacers (PS)
– 1 1/8" OD x 1/2" ID x 1" (GER3PSAA): used as a spacer in order to fasten directly to the wall behind the Panel.

Recommended Tool List

- Extension Cord
- Safety Glasses
- Ladder
- Tape Measure & Pencil
- Level (4')
- White Rubber Mallet
- Power Miter Saw or Circular Saw (with 80 tooth blade)
- Jigsaw (with 80 fine tooth blade)
- Hammer Drill (with concrete bits)
- Cordless Drill (with drill & driver bits)
- Hole Saw Kit (for cordless drill)
- Screws (for concrete walls use galvanized concrete screws e.g. Tapcon - $\frac{3}{16}$ " x 1 $\frac{1}{4}$ ")
- Caulking Gun
- Caulking (one part neutral cure, oxime silicone) such as:
 - Dow 1199 by DOW CORNING (Tel: 1-800-322-8723) Web: www.dowcorning.com
 - Tremsil 600 by TREMCO (Tel: 1-800-363-3213) Web: www.tremcosealants.com
 - Bondaflex Sil 200 GPN by BONDAFLEX TECHNOLOGIES (Tel: 1-800-641-0234) Web: www.bondaflex.com

General Tips

- 1 Panels can be ordered in standard lengths of 12', 14', 16' or 18', or can be ordered cut to size from the factory.
- 2 Panels should not sit flush with the floor. Panels should be installed a minimum of 1" above the finished floor in order to allow for proper drainage if installing in an environment where water is present (i.e. car wash).
- 3 If ordering Panels cut to size from the factory, ensure that the wall heights are consistent through the building. Wall heights may vary due to slab irregularities.
- 4 Verify site measurements along the full length of the wall and ceilings. Change the lengths of the Panels for each $\frac{1}{8}$ " \pm variation in site dimensions.
- 5 Always start from a corner or opening and work your way out. If the wall contains a penetration (e.g. pipe), you may want to start at the wall penetration and work towards the corner.
- 6 Using a 4' level, periodically check to ensure that the Wall Panels are installed plumb.
- 7 Use approved caulking at all joints, miter cuts, etc... (required for appearance only).
- 8 Strapping might be required on uneven walls and ceilings at joists (if joists are not perpendicular to ceiling material).
- 9 Panels are installed in pairs for walls (Joiners at 30 $\frac{5}{16}$ " o/c);
Panels are installed singly for ceilings (Joiners at 16 $\frac{1}{16}$ " o/c).
- 10 For expansion and contraction provide the following clearances:
 - $\frac{3}{8}$ " gap at top end of all Panels for walls
 - $\frac{1}{4}$ " gap at each end of all Panels for ceilings
 - $\frac{1}{16}$ " gap at each side of all Panels for walls and ceilings

Important Note

- 11 The Renu Panels shall be installed at temperatures above 40°F (5°C). All pieces stored at lower temperatures shall be heated before installation.
- 12 The recommended service temperature for the Renu Panel is 122°F (50°C). The product shall not be directly exposed to flame or any radiant heating sources. Generally, heaters, including radiant heaters, must not be located less than 18" from Renu Panels. Contact the manufacturer of any heater or radiant heater for installation details and the required clearances from the Renu Panels.

Preparation

- 13 Ensure the work area is clear of any debris or items that would impede installation. Pay special attention to the bottom of walls and ensure that there is no protruding concrete or debris that will prevent the Wall Panels from resting flush against the wall.
- 14 Create Wall Sections by sliding two Panels (RP) together.
- 15 Pre-cut all the Panels, Trim Tracks, Trim Caps, Corner Trims, Cap Joiners and Base Joiners to the correct length. Refer to Figure A for wall only installation. Refer to Figures B and C for wall and ceiling installation.
- 16 A layer of 6 mil polyethylene is recommended behind the Renu Panels as a vapor barrier for walls and ceilings constructed with wood or steel framing.

A Wall Only Installation

Figure A

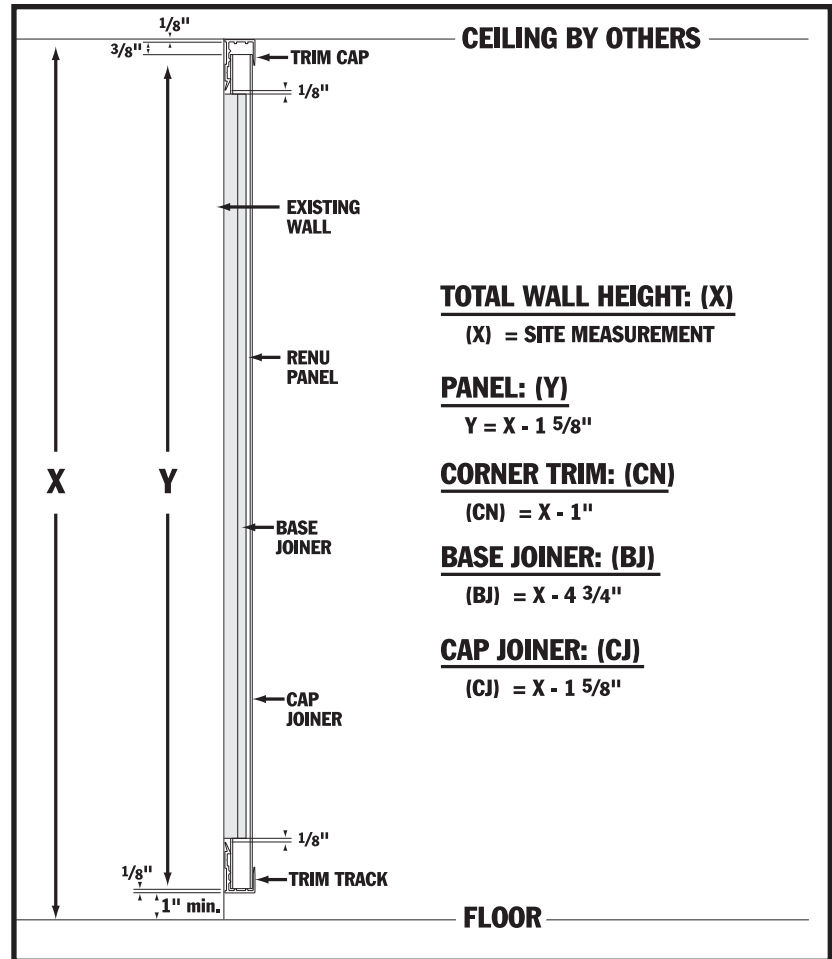

A1 Install a Trim Track to the wall, a minimum of 1" off the floor and 3" from corner, using the recommended screws. Install an inverted Trim Track to the wall, tight to underside of ceiling and 3" from corner, using the recommended screws. Ensure that the screws are fastened in the recessed portion of the track. This will prevent the screw heads from interfering with the Panels. **TIP:** Cut the back legs of the Trim Track short by 1/2" to avoid interference with the back legs of the Corner Trim.

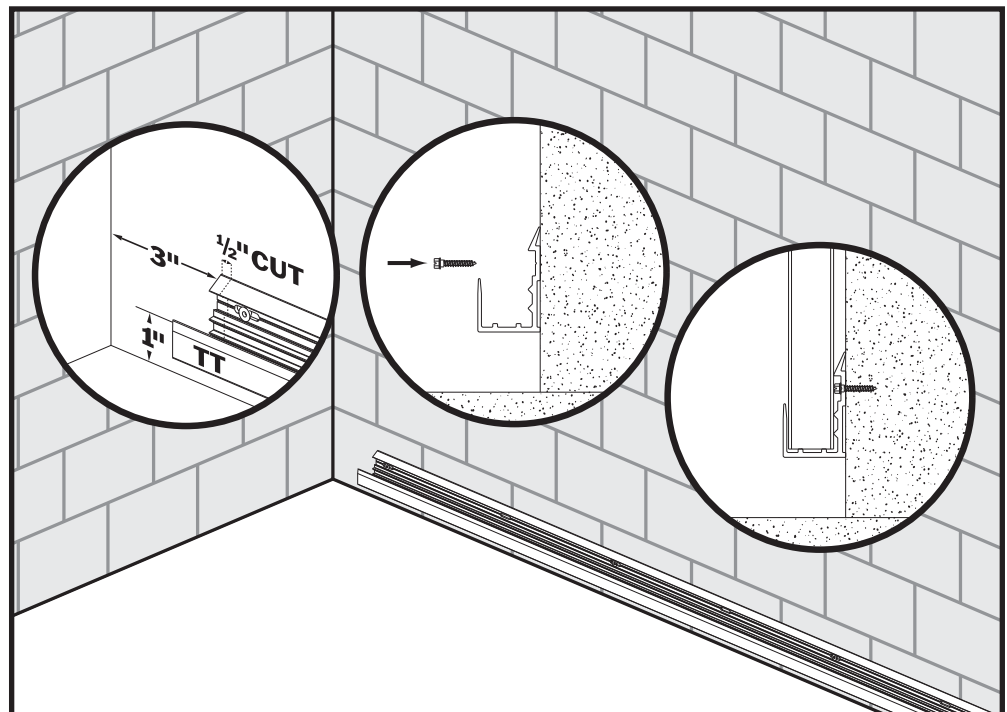

A2

Starting in one corner, assemble a Wall Section (2 x RP) with the male side towards the corner. Lift the top of the Wall

Section up into the top Trim Track. Flex the Wall Section and insert the bottom of the Wall Section into the bottom Trim Track. Place a Corner Trim in the corner and push the Wall Section into the Corner Trim completely so that there is a maximum of a $\frac{1}{16}$ " gap. Fasten the back leg of the Corner Trim in place with a screw 1" from the top as per step A8.

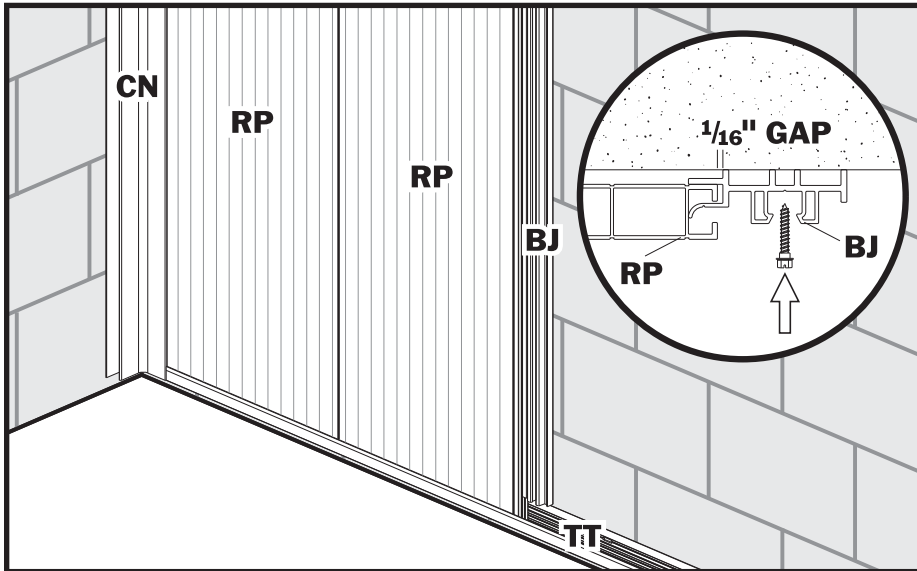
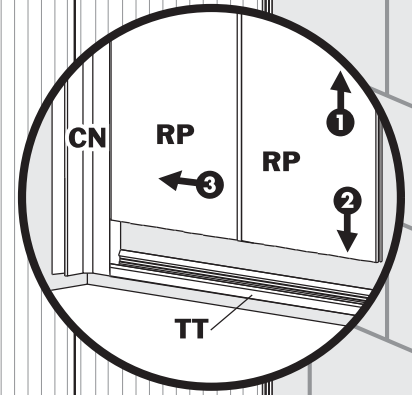
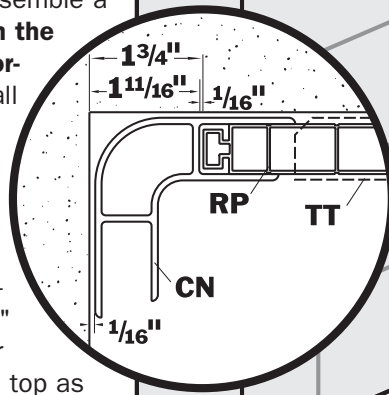

A3

Next, install a Base Joiner by pushing it onto the back leg of the Panel. **The curved leg of the Base Joiner shall touch the web of the Panel but shall not be bent.**

This will provide $\frac{1}{16}$ " for thermal expansion. Use a level to ensure that the Base Joiner is plumb. Drill $\frac{3}{16}$ " holes in the center of the Base Joiner, through into the wall, approximately every 16" on center. Next, fasten the Base Joiner to the wall using the recommended screws. Ensure that the Base Joiner does not extend into the Trim Tracks. The Base Joiner shall be $\frac{1}{8}$ " clear of the Trim Tracks.

A4

Install another pre-assembled Wall Section.

Insert the top of the Wall Section into the top of the Base Joiner and slide the top of the Wall Section up into the top Trim Track. Flex the Wall Section and insert the bottom of the Wall Section into the bottom of the Base Joiner and slide into the bottom Trim Track.

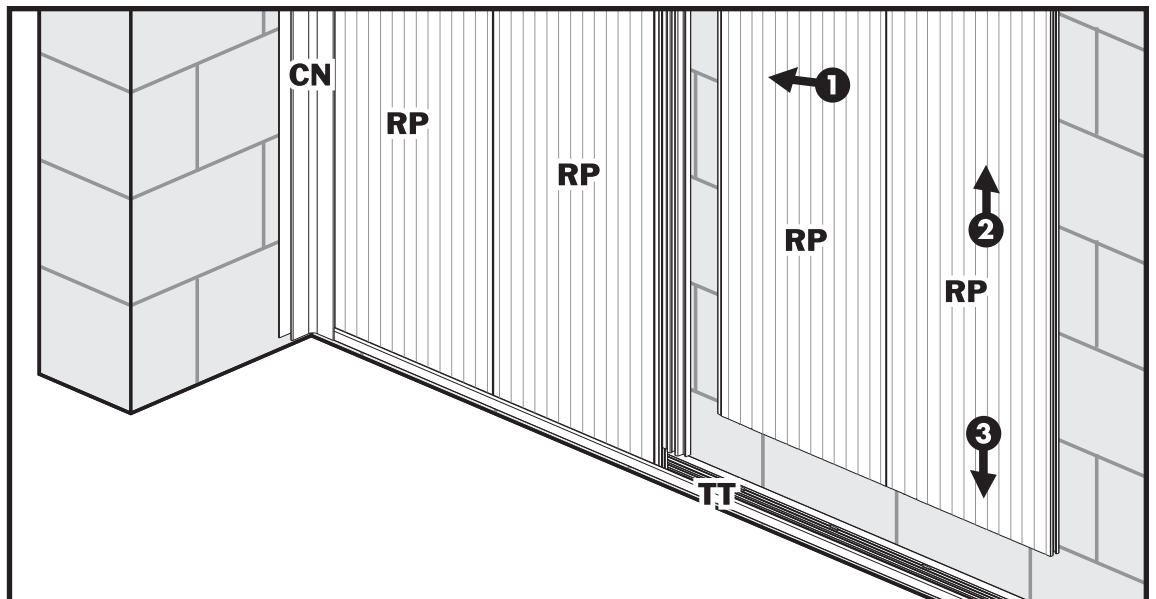

A5 Now that two Wall Sections are positioned at opposite sides of the Base Joiner, place a Cap Joiner over the Base Joiner. Insert the top of the Cap Joiner into the top Trim Track. Flex the Cap Joiner and insert the bottom of the Cap Joiner into the bottom Trim Track. Snap the Cap Joiner into the Base Joiner with a white rubber mallet. **Do not use steel hammers.**

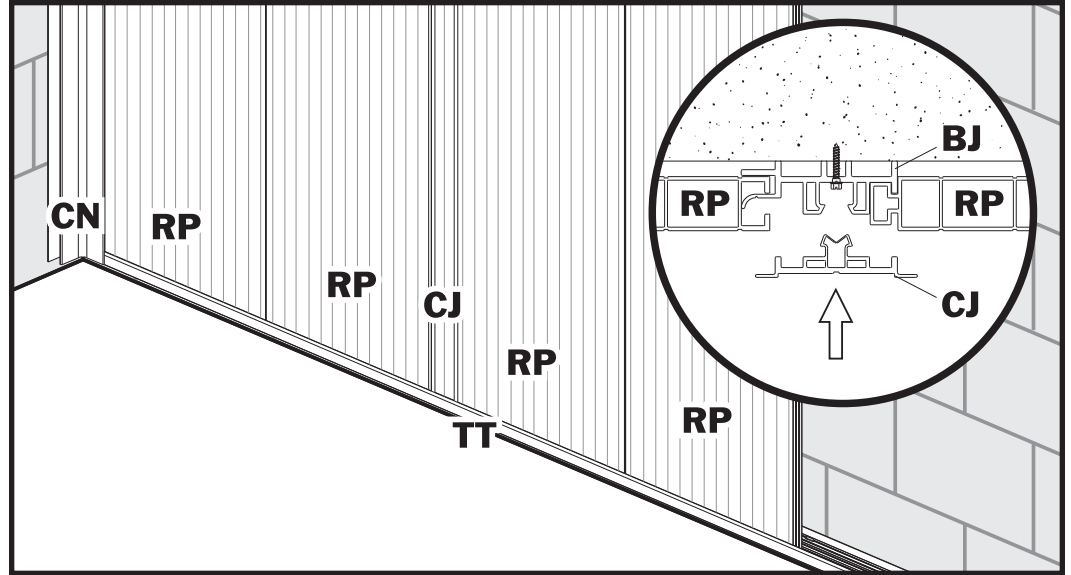

A6 Continue with steps A3 to A5 until you reach another corner of the building. The side of the last Wall Panel section may need to be site cut using a jigsaw or circular saw. Install the last Wall Section and slide into the Corner Trim as per step 2. **TIP:** Do not anchor the last Base Joiner until after the last Wall Section is installed.

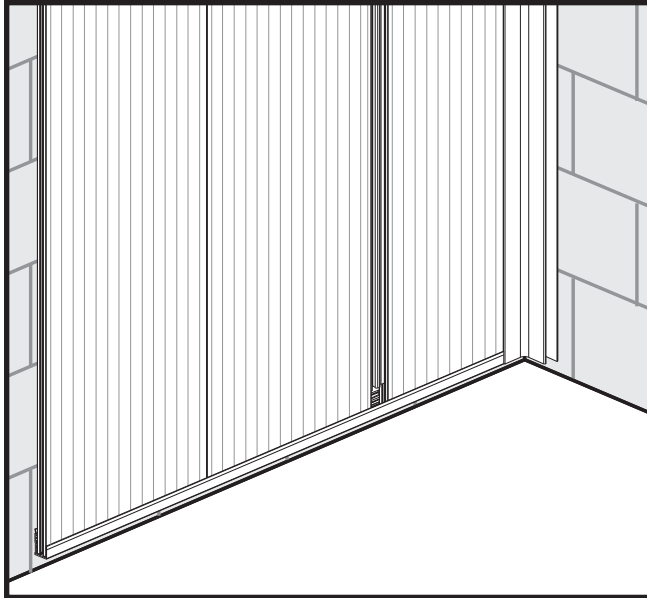

A7

Install Trim Cap around all doors, windows and other openings prior to installing Wall Sections. Miter cut the corners of the Trim Cap and seal with approved caulking. Cut the Panels as required to provide $\frac{1}{16}$ " clearance minimum from the Panels to the inside of the Trim Cap.

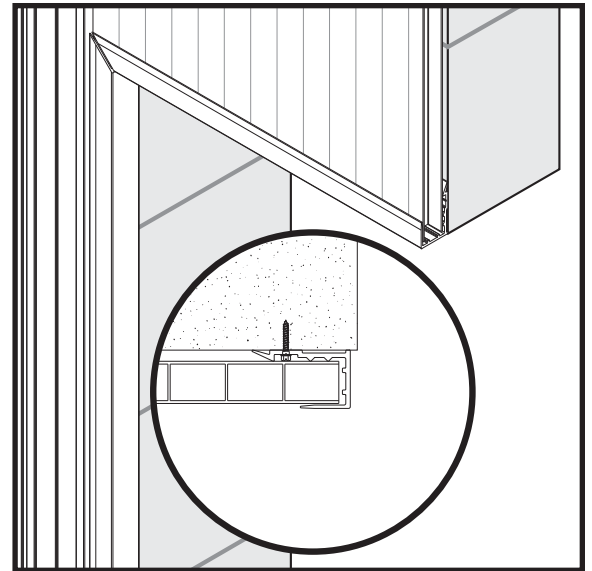

A8 In certain circumstances it will be necessary to fasten a Panel directly to the concrete wall without using the Base Joiner. In this case, pre-drill a $\frac{3}{8}$ " hole into the panel, through the outer surface face only. Next fasten the Panel to the wall using the recommended fasteners. Provide $\frac{3}{16}$ " clearance to the wall, do not over tighten the screws. Finally, use the Plastic Plugs as a finishing cap to cover the $\frac{3}{8}$ " hole in the Panel.

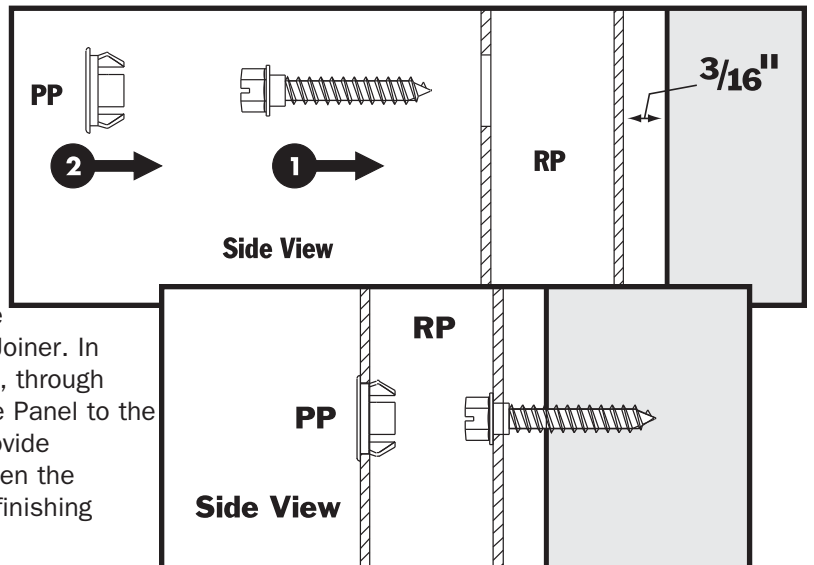

Wall Cut-Outs for Mounting Brackets

Cut-outs, less than 16" square, for mounting brackets or other accessories to the wall can be handled in two ways as noted in steps A9 and A10. For large openings cut after installation of the Panels, fasten the Trim Cap and Panels as per step A8.

A9 Panels can be cut using a jigsaw to create an opening in the Wall

Trim Cap is used as a finishing trim around the opening.

Accessories can then be fastened directly to the wall. This technique works well for large brackets/accessories especially if required to carry heavy loads (e.g. car wash overhead equipment).

TIP: Miter cut the Trim Cap corners and seal in place

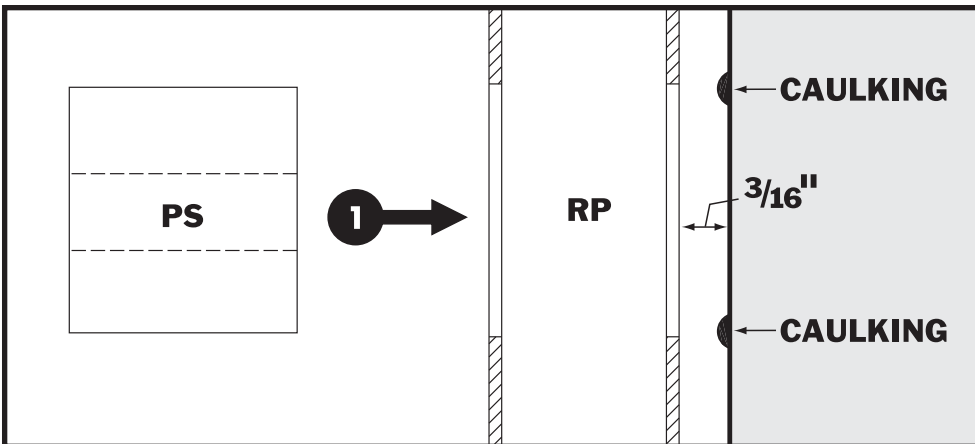
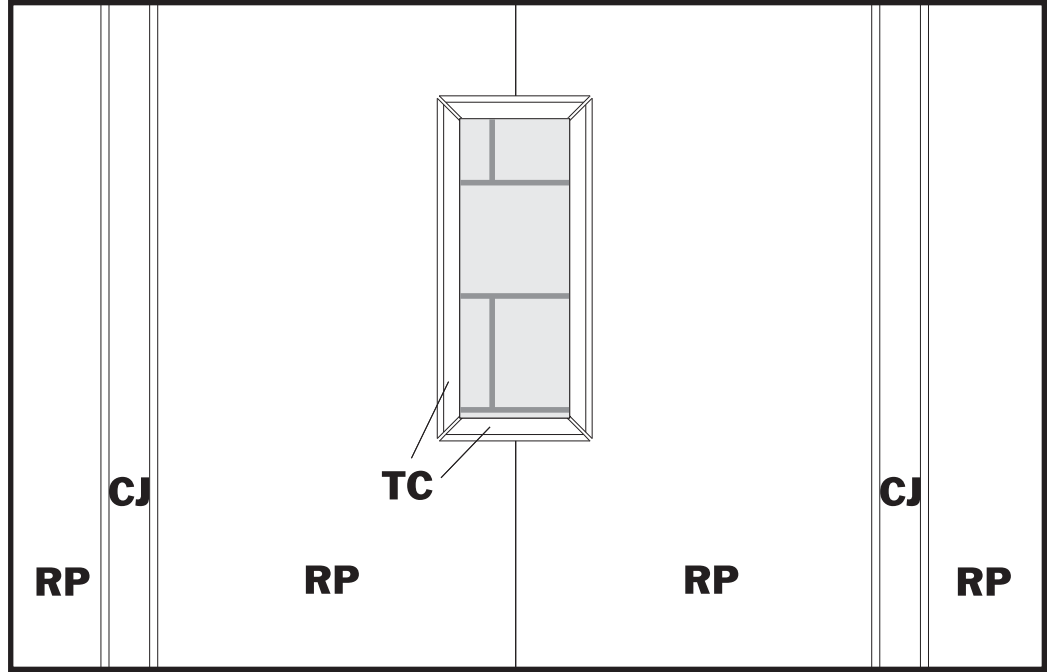

A10 Using a 1 1/8" hole saw, drill a hole in the Panel. Apply a bead of approved caulking to the wall behind the hole and then install the Plastic Spacer. The Plastic Spacer should be flush to the outside surface of the Panel. Fasten the brackets/accessories to the wall through the hole in the Plastic Spacer. **TIP:** Apply a bead of approved caulking around the Plastic Spacer to the face of the Panel.

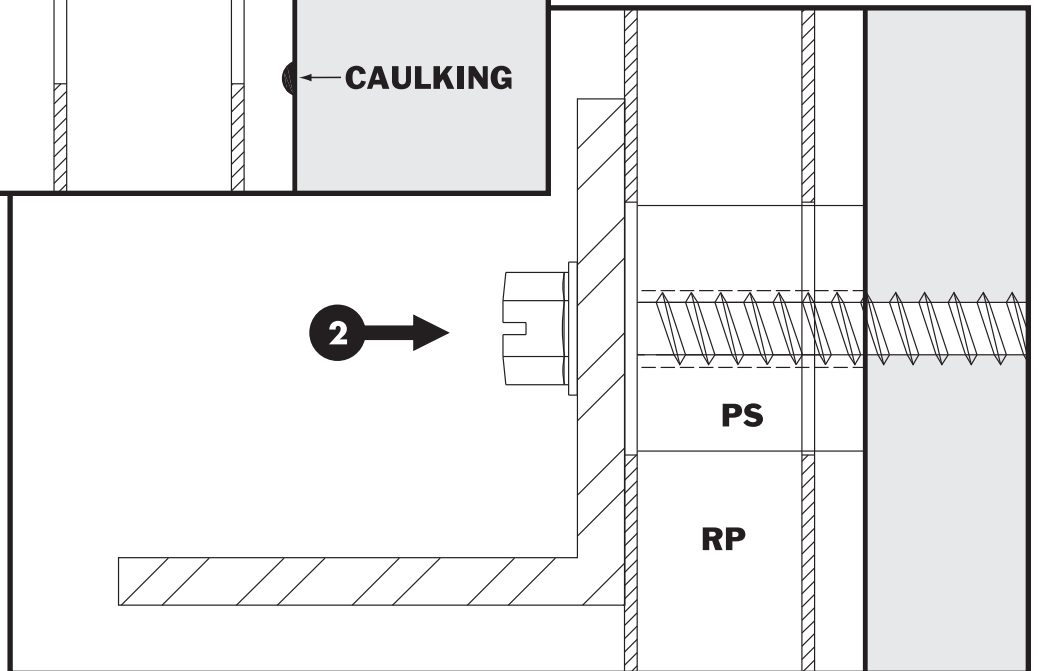

B Wall & Ceiling Installation

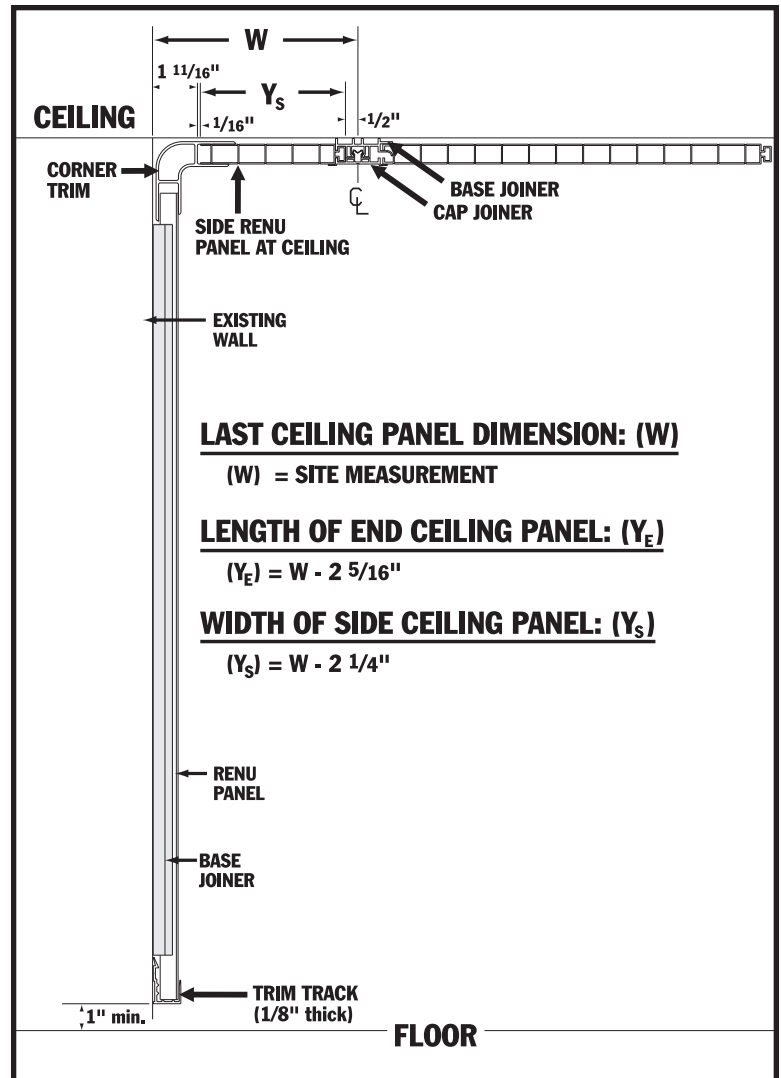
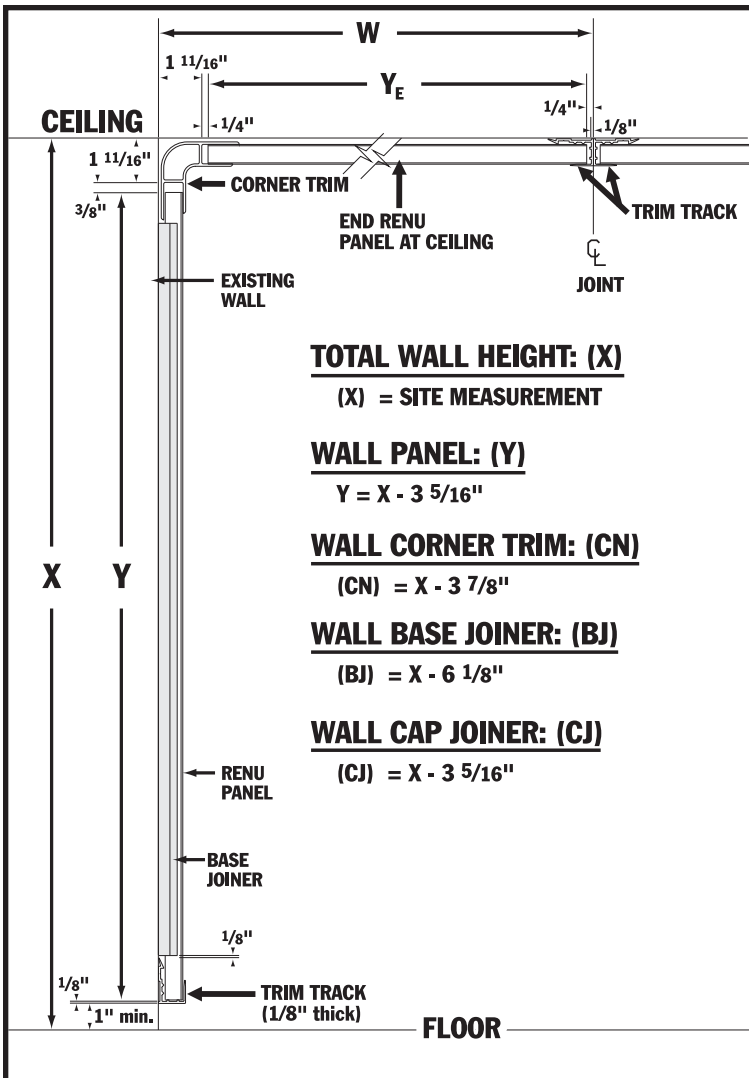

Figure B: Section Parallel to Panels

Figure C: Section Perpendicular to Panels

Wall Installation

B1

Follow steps A1 to A8 of "WALL ONLY INSTALLATION" except:

- do not install Trim Track at ceiling
- cut rear leg of wall Corner Trim $\frac{1}{2}''$ low to suit Corner Trim placed at ceiling
- install Wall Panels and Cap Joiners into bottom Trim Track
- in order to facilitate the installation of the Corner Trim at the ceiling, do not fasten the top 4' of every Cap Joiner. This will provide a "degree of play" between the Panels and the wall and will simplify the installation of the Corner Trim by bending the top of the Wall Panels outward.

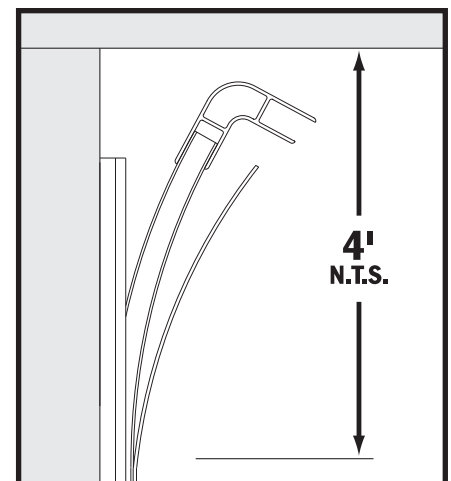

Ceiling Installation

B2 The Renu Panels are installed as a ceiling at underside of joists or strapping. Use a Base Joiner and Cap Joiner between every Panel (16 1/16" o/c). If ceiling length is less than 18', it is recommended to install Panels lengthwise from sidewall to sidewall. This will avoid having a joint in the ceiling. If a joint is required, see item B8 for details on how to create a joint in the ceiling.

B3 Select an appropriate fastener type depending on the type of framing material for the roof joists or strapping (i.e. wood or metal). Connect the Base Joiners to the roof members at 24" on center maximum and at 6" from each end. For Base Joiners perpendicular to the roof joists or strapping that are more than 16" on center, the Base Joiner must be temporarily supported from above as the Cap Joiners are installed. If the ceiling space is inadequate for access to support the Base Joiners, provide strapping or blocking perpendicular to the Base Joiners at 16" on center maximum or provide strapping continuously above each Base Joiner. Provide a vapor barrier, such as 6 mil polyethylene sheeting, above the Renu Panels to protect the roof members or strapping from moisture. **TIP:** Seal the vapor barrier to the perimeter wall and at all joints with approved adhesive tape or fasteners.

B4 Use a Corner Trim on the top of the walls. Miter cut the Corner Trim at the inside corners of the building. Install the Corner Trim by bending the top of the Wall Sections outward. Refer to Wall Installation step B1. **TIP:** Provide 1/8" gap at miter cuts and seal with approved caulking.

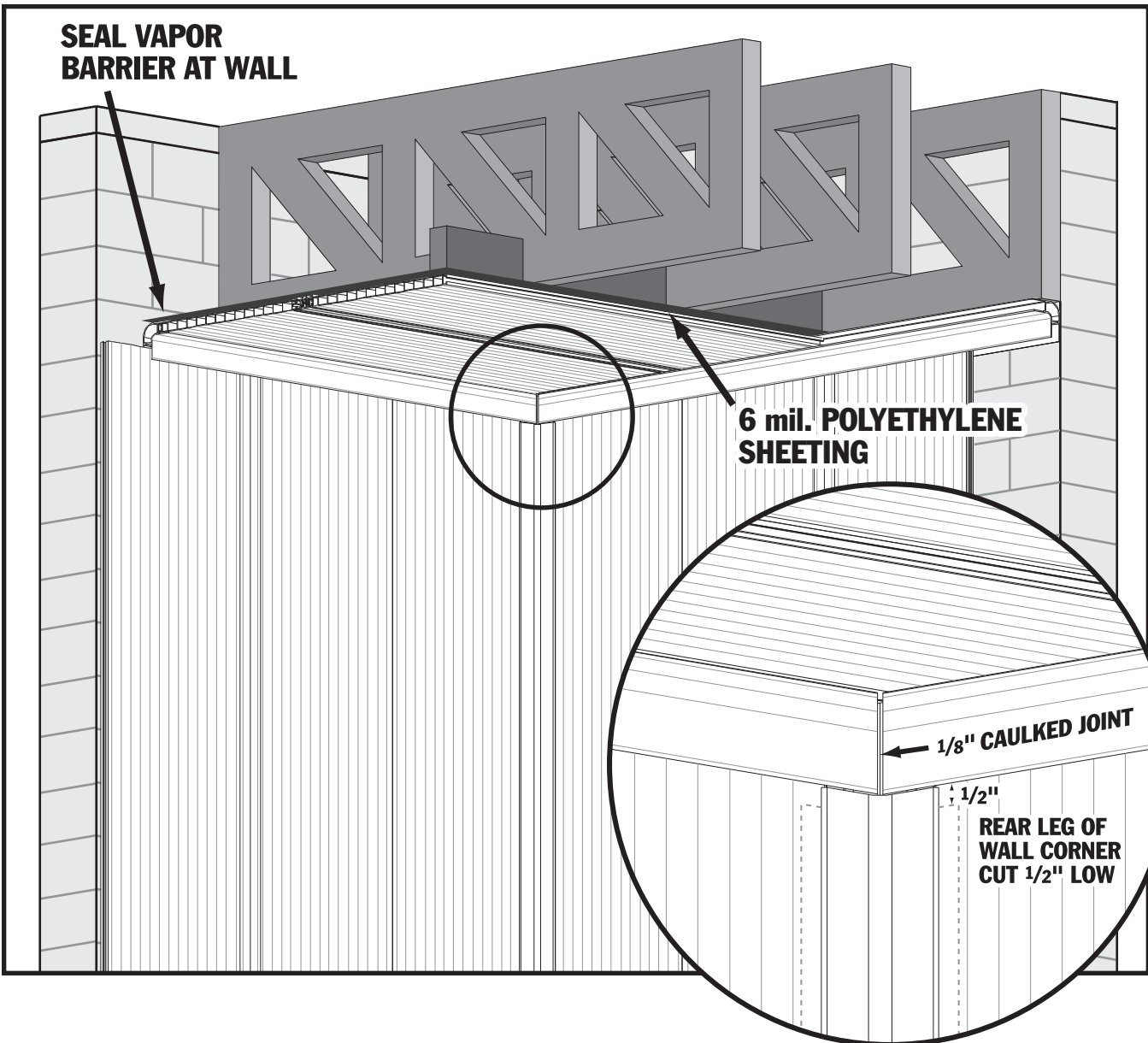

B5 Install Panels for ceiling into Corner Trim pieces by inserting one end and flexing the Panels to insert the other end into a Corner Trim or Trim Track. Provide $\frac{1}{4}$ " clearance at ends of Panels as shown. **Start with the male side of a Panel fitting into the Corner Trim** on a side wall and provide $\frac{1}{16}$ " maximum clearance at side of Panel.

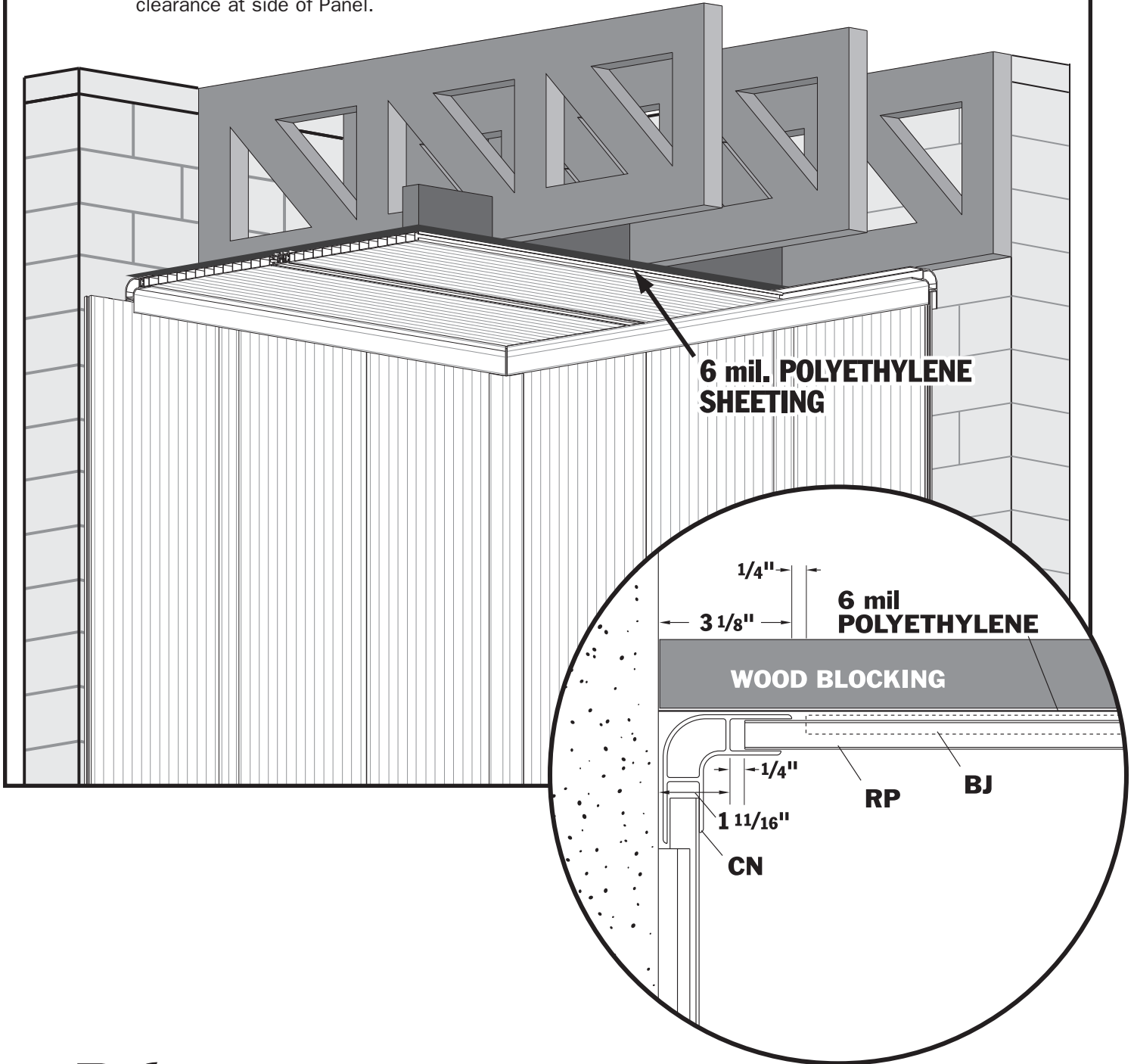

B6 Install Base Joiner to Female side of Panel and anchor to framing. Lift next Panel into Base Joiner and snap Cap Joiner in place. Similar to steps A3 to A5 for "WALL ONLY INSTALLATION".

TIP: Provide support for base of Base Joiner as noted in

B7 Continue to repeat step B6 until you reach the other side of the ceiling. The last ceiling Panel may need to be site cut using a jigsaw or circular saw. Install each end and slide into Corner Trim, providing $\frac{1}{16}$ " clearance. **TIP:** Do not anchor the last Base Joiner until after the last Panel is installed.

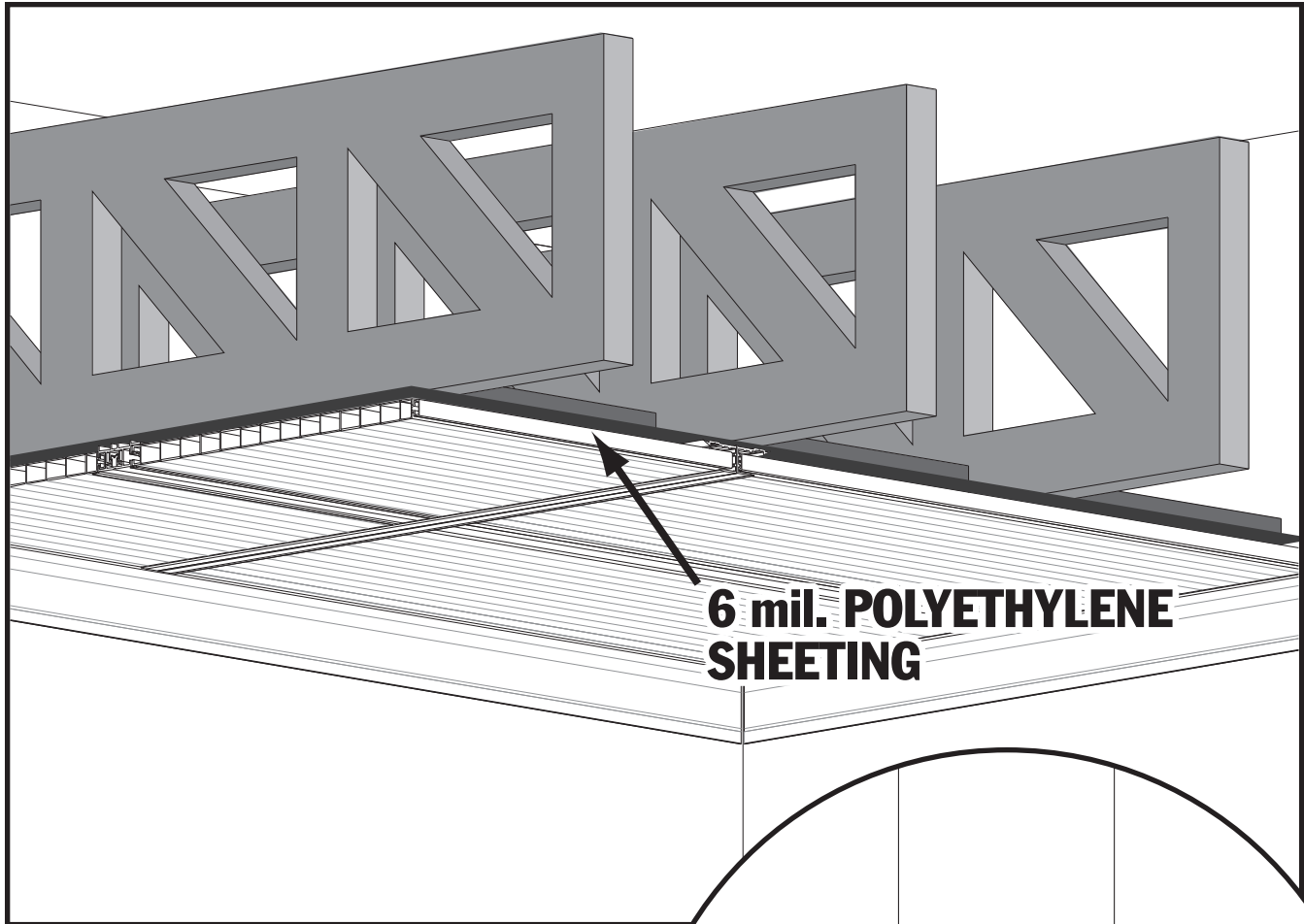

6 mil. POLYETHYLENE SHEETING

B8 If installing under roof joists (wood or metal), Panels should run perpendicular to the roof joists. If the ceiling is longer than 18', a joint will be required. Create a ceiling joint by fastening two Trim Tracks back to back with #6 x $\frac{1}{2}$ " screws at 16" on center. Fasten Trim Tracks onto ceiling joist and provide additional blocking as required. Provide $\frac{1}{4}$ " clearance at end of each Panel.

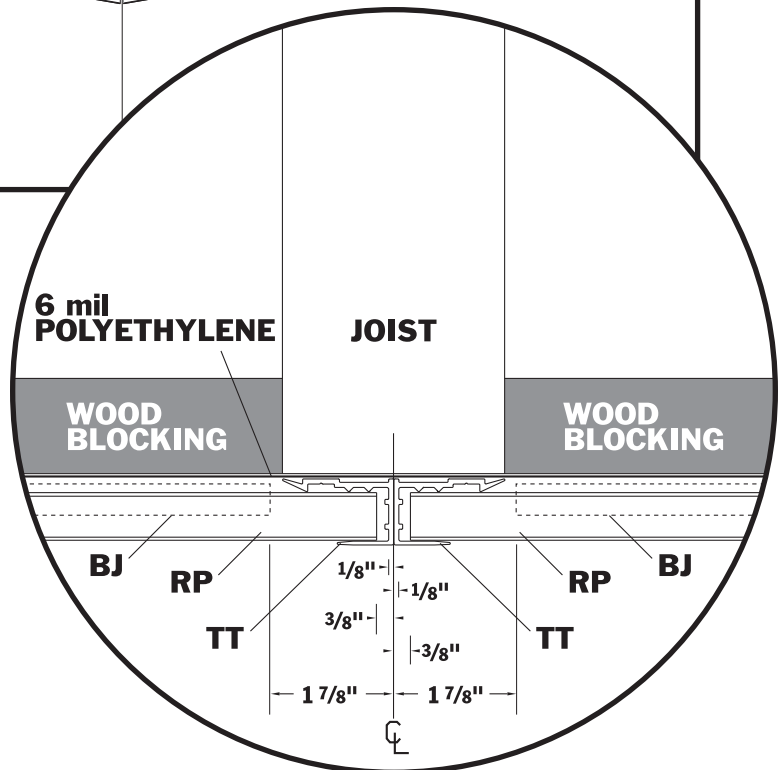



Cleaning the Renu Panels*

Renu Panels are made of a durable material and should provide many years of low maintenance. The Renu Panels require only periodic maintenance using a general cleaner applied with a soft cloth or soft bristle brush. The recommended cleaner is **REVIVE**, a non-toxic cleaner available from Nuform Building Technologies Inc.

For localized areas with heavy stains, other suggested cleaners are Vinegar/Water, Murphy's Oil, Fantastic, vinyl product cleaners or other household cleaners.

For tougher stains (e.g. graffiti), use **Nuform Graffiti Remover**, available from Nuform Building Technologies Inc.

Some cleaners may damage the finish of the Renu Panels and must be tested.* Some of the non-recommended cleaners are Clorox, Pine Power, Tide Power, Grease Relief and Nail Polish Remover.

If you have any questions or comments, please do not hesitate to contact Nuform Building Technologies Inc. at 1-877-747-WALL (9255) or e-mail us at info@nuformdirect.com

* Stain removal is affected by factors such as area involved, severity of stain, and duration of exposure. The recommended cleaners noted above were found to be adequate, but shall not be taken as a warrant or guarantee. The method of removal of a specific stain should be determined by testing a small sample area first, or by contacting Nuform for further information.



Nuform Building Technologies Inc.

1 Regalcrest Court, Woodbridge, Ontario, Canada L4L 8P3
Toll Free: 1-877-747-WALL (9255) (905) 625-0001 Fax: (905) 625-0002

www.nuformdirect.com