



The Pre-Finished, Stay-in-Place  
Concrete Wall Formwork

# CONSTRUCTION GUIDE

VERSION 3.0





## BUILDING SOLUTIONS FOR A BETTER WORLD...

Nuform Building Technologies Inc. is an innovative quality-driven building technologies company. Since the introduction of CONFORM® (formerly Royal Building Systems™) in 1992, the product has received global recognition for its approach in providing an innovative solution to the construction industry.

CONFORM is a patented polymer-based stay-in-place formwork for concrete walls. The extruded components slide and interconnect together to create a concrete formwork. The result is permanent, attractive, and pre-finished concrete walls that can be easily constructed in any climate.

CONFORM is composed of numerous modular components for 100mm, 150mm and 200mm (4", 6" and 8") concrete walls that can be assembled to suit any wall layout, whether you are building a vehicle wash, an agricultural facility or a large industrial building.

CONFORM requires no painting, and resists ultraviolet radiation. The polymer components will not decay or deteriorate over a lifespan that can be measured in decades. Furthermore, CONFORM is highly durable, virtually maintenance free, impervious to weather, and energy efficient.

CONFORM is manufactured using 'R3' extrusion technology as an environmentally friendly product. The polymer components contain over 55% recycled content and are recyclable, energy efficient, mold and mildew resistant and non-toxic.

CONFORM offers complete design flexibility and an innovative building product that is easy to maintain, friendly to the environment, and built to last. Whether you are a developer, contractor, architect, engineer, or designer you can find attractive and cost effective solutions for your next project with CONFORM.



# CONTENTS

<b>1. INTRODUCTION</b> .....	<b>1</b>	<b>11. BRACING</b> .....	<b>35</b>
<b>2. PROJECT ORGANIZATION</b> .....	<b>2</b>	11.1 General.....	35
2.1 General.....	2	11.2 Base of Wall .....	35
2.2 Planning.....	2	11.3 Mid-Height of Wall.....	36
2.3 Individual Components.....	3	11.4 Top of Wall.....	37
2.4 Pre-assembled Wall Sections .....	4	11.5 Ends, Corners, Intersections .....	37
<b>3. WALL MATERIALS</b> .....	<b>5</b>	11.6 Wall Openings.....	39
3.1 CONFORM® Components.....	5	<b>12. CONCRETE PLACEMENT</b> .....	<b>41</b>
3.2 Concrete Mix .....	8	12.1 Concrete Pour.....	41
3.3 Steel Reinforcing Bars .....	9	12.2 Inserts .....	43
3.4 Fasteners, Bracing, Others .....	10	12.3 Washing.....	43
<b>4. EQUIPMENT</b> .....	<b>11</b>	12.4 Remedial Measures .....	43
4.1 Hand Tools .....	11	12.5 Bracing.....	43
4.2 Power Tools .....	11	<b>13. FINISHING</b> .....	<b>44</b>
4.3 Erection Equipment.....	12	13.1 Clean-Up .....	44
4.4 Construction Equipment.....	12	13.2 Multi-storey Band .....	44
<b>5. SAFETY</b> .....	<b>13</b>	13.3 Caulking.....	44
5.1 Workmen.....	13	13.4 Maintenance.....	45
5.2 Weather Conditions.....	13	<b>14. CONFORM® REPAIR</b> .....	<b>47</b>
<b>6. SITE PREPARATIONS</b> .....	<b>14</b>	14.1 Patching.....	47
6.1 Site Grading and Access .....	14	14.2 Materials and Tools Required .....	47
6.2 Storage of Material.....	14	14.3 Repairing Surface Damage - Patching Holes Non-insulated face..	48
6.3 Foundations.....	15	14.4 Repairing Surface Damage - Patching Cracks or Butt Joints....	49
6.4 Wall Dowels .....	15	14.5 CF8i Exterior Face Repair.....	49
6.5 Underground Services.....	16	<b>15. ALTERNATE WALL FINISHES</b> .....	<b>52</b>
6.6 Electrical Power.....	16	15.1 CONFORM® .....	52
6.7 Water Supply .....	16	15.2 Acrylic Stucco - General .....	52
<b>7. WALL ERECTION - GENERAL</b> .....	<b>16</b>	15.3 Stucco - Direct Apply Method.....	52
7.1 Orientation.....	16	15.4 Stucco - EIFS System Method .....	53
7.2 Layout.....	17	15.5 Vinyl Graphics.....	53
7.3 Erection Procedure.....	18	15.6 Paint .....	54
7.4 Wall Length .....	19	15.7 Insulation and Siding.....	54
7.5 Starters.....	20	15.8 Gypsum Board .....	57
7.6 Doors, Windows, Openings.....	20	<b>APPENDIX A</b>	
7.7 Electrical.....	23	- <b>CONSTRUCTION BULLETINS</b> .....	<b>58</b>
<b>8. WALL ERECTION</b>		<b>APPENDIX B</b>	
- <b>INDIVIDUAL COMPONENTS</b> .....	<b>24</b>	- <b>BRACING FOR CONFORM®</b> .....	<b>59</b>
8.1 Erection Procedure.....	24	B.1 General.....	59
8.2 Erection Sequence .....	24	B.2 Bracing Design Guidelines.....	60
<b>9. WALL ERECTION</b>		B.3 Single Bracing .....	61
- <b>PRE-ASSEMBLED WALL SECTIONS</b> .....	<b>26</b>	B.4 Double Bracing.....	64
9.1 Erection Procedure - Low Walls ....	26	B.5 Vertical Bracing at Corners, I-Intersections and Ends .....	67
9.2 Individual Components.....	28	B.6 Bracing at Openings .....	70
9.3 Erection Procedure - High Walls ...	28	B.7 Bracing at Piers, Columns and Double Walls .....	72
9.4 Doors, Windows, Openings .....	30	B.8 Bracing Example .....	73
<b>10. PLACEMENT OF STEEL</b>			
<b>REINFORCING BARS</b> .....	<b>30</b>		
10.1 General.....	31		
10.2 Corner Reinforcing Bars.....	32		
10.3 Placement Sequence.....	33		

# 1. INTRODUCTION

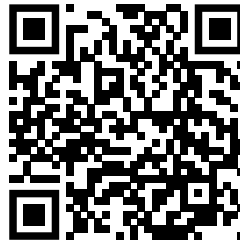
This Construction Guide has been prepared by Nuform Building Technologies Inc. (NUFORM®) to assist contractors, engineers and architects in the understanding of the construction procedures for bearing walls using CONFORM®. It is a part of our continuing effort to provide current and practical information to the users of CONFORM.

The Construction Guide provides information on the following aspects of construction using CONFORM:

- Project Organization
- Wall Materials
- Equipment
- Safety
- Site Preparation
- Wall Erection - General
- Wall Erection - Individual components
- Wall Erection - Pre-assembled Wall Sections
- Placement of Steel Reinforcing Bars
- Bracing
- Concrete Placement
- Finishing
- Repair
- Alternate Finishes

In addition to this Construction Guide, the following guides are also available to assist in designing and building your projects using CONFORM:

- Technical Guide
  - Engineering Guide
- [nuformdirect.com/resources/guides/](http://nuformdirect.com/resources/guides/)



Although every effort has been made to ensure that all the information provided in the Construction Guide is factual and consistent with good construction practice, NUFORM does not assume any liability for errors or oversights resulting from the use of information contained in this guide. Anyone making use of the information provided in these guides assumes all liability arising from such use.

The suggested suppliers for various products described in this guide are for information purposes, only. NUFORM does not warrant or guarantee the performance the performance of any of the products. Please consult each supplier for specific information regarding their products, and recommended application and warranty, if any.



1.0 Bearing Wall Project

## 2. PROJECT ORGANIZATION

### 2.1 GENERAL

1. CONFORM® consists of extruded rigid polymer components that serve as a stay-in-place formwork for concrete walls including bearing walls, non-bearing walls, shear walls, retaining walls and foundation walls. The extruded components slide and interconnect together to create a concrete formwork that remains in place after the concrete is poured and cured. Four different CONFORM types are available, as identified in the following Table 2.1:

TABLE 2.1: CONFORM

CONFORM	Wall Thickness		
	Overall (Nominal)	Concrete Core	Insulation <sup>1</sup>
CF4	100 mm (4")	95 mm (3.74")	0
CF6	150 mm (6")	145 mm (5.71")	0
CF8	200 mm (8")	195 mm (7.67")	0
CF8i	200 mm (8")	139 mm (5.47")	54 mm (2.13")

2. The time to erect and brace CONFORM depends on the specific project. General guidelines are provided in sections 2.3 and 2.4.

3. The time to place the concrete in CONFORM depends on the placement method. With a concrete pump, an average of 225 m<sup>3</sup> or (300 yd<sup>3</sup>) can be placed in a 10 hour day (22.5 m<sup>3</sup> (30 yd<sup>3</sup>) per hour). However, this can vary significantly depending on the project.

### 2.2 PLANNING

1. The planning and preparation of the site, materials, equipment and related trades varies with each project and can greatly affect the erection and economy of CONFORM.

2. It cannot be overstated how important it is to have all activities prepared and coordinated prior to starting erection of CONFORM. CONFORM is based on a concept of sliding components together, which is so simple and easy that any difficulties with any other aspect of the work can greatly hamper and delay the CONFORM erection. Only if all activities are pre-planned and well organized can CONFORM be erected in an efficient and economical manner.

3. One of the major construction decisions regarding the planning and organization is whether to erect the CONFORM components individually or in pre-assembled wall sections. This affects all aspects of the project: the CONFORM drawings, shipping, off-loading, storage, bracing, erection methods, construction schedule and project costs.

4. The decision to ship and erect CONFORM using individual components or pre-assembled wall sections is based on the project size, the wall height and the availability of construction equipment. The following is a general guide in selecting the appropriate erection method:

TABLE 2.2: CONFORM ERECTION METHODS

CF4	<ul style="list-style-type: none"> <li>CF4 walls are erected individually and not pre-assembled, except for headers and sills and for walls of selected custom projects</li> </ul>
CF6 & CF8	<ul style="list-style-type: none"> <li>CF6 and CF8 walls less than 4300 mm (14') high are erected individually except for walls of unique projects and for headers and sills.</li> <li>Pre-assembled wall sections are used for walls over 4300 mm (14') high</li> </ul>
CF8i	<ul style="list-style-type: none"> <li>CF8i walls less than 3000 mm (10') high are erected individually and are not pre-assembled except for walls of unique projects and for headers and sills.</li> <li>Pre-assembled wall sections are used for walls over 3000 mm (10') high</li> </ul>

(1) The CF8i components are pre-insulated with 54 mm (2.13") of polyurethane insulation. The insulation cavity is on the exterior side of the wall and protected from the interior with the non-combustible concrete core.

5. Also, the decision to ship and erect CONFORM using individual components or pre-assembled wall sections is based on the site storage, the amount of double handling, the erection sequence and the erection costs. For individual components, the labor costs for off-loading, sorting, handling and erection are increased. For pre-assembled wall sections, the cost for shipping and equipment rentals are increased.

6. Once the erection method is finalized, the erection sequence must be determined. The erection sequence affects the shipping, off-loading, material handling, construction methods and construction schedule. The erection sequence is selected, for each project, to minimize the construction time and material handling based on the site conditions, bracing requirements, reinforcing bar spacing and the available equipment.



2.2 Bearing Wall Project in Progress

### 2.3 INDIVIDUAL COMPONENTS

1. Typically, individual components are used for small projects that are not more than 900 m<sup>2</sup> (10,000 sq. ft.), where wall heights are less than 4.3 m (14') or where the use of a boom truck, scissors lift and telescopic boom lift is not practical.

2. Components that are shipped individually require less trucking space since the components can be stacked tightly to completely fill a closed trailer or container. The individual CONFORM

components are manually loaded and unloaded from the closed trailer. Generally, it takes approximately 4 hours for 6 men to unload a 53' trailer or a 40' container. The components are stored in neat piles as close as possible to the final wall locations.

3. Alternately, the individual components can be packaged onto skids and loaded and unloaded from a closed trailer or an open flat-bed with a forklift. This is very helpful for multi-level construction since the skids of material can be placed directly on the upper floor slabs. Each skid of material is approximately 450 kg (1000 lb).

4. The components must be well organized at the site and are erected manually piece by piece as CONFORM is assembled.

5. The individual components are erected manually from ladders, rolling scaffolds or man-lifts. Approximately 40 lineal meters (120 lineal feet) of wall, 4.5 m (14') high, can be erected and braced in a day with a crew of 6 men working for 10 hours.

6. The bracing is erected as the CONFORM erection progresses and typically involves light framing using wood or cold formed steel members.



2.3 Construction using Individual Components

## 2.4 PRE-ASSEMBLED WALL SECTIONS

1. Typically, pre-assembled wall sections are used for large projects that are over 900 m<sup>2</sup> (10,000 sq. ft.), where wall heights are over 4.3 m (14') and where the use of a crane, scissors lift and telescopic-boom lift is practical due to the size and scope of the project.



2.4a Pre-assembled Wall Sections for Off-Loading with Crane

2. The components are pre-assembled at the manufacturing facility into large wall sections. Typically, the wall sections are full height and are 2250 mm (7'-4") wide, maximum side. Some of the components near corners, intersections and openings are shipped loose along with components inbetween preassembled sections.

3. The wall sections are shipped on open flat bed trailers. The trucks allow 2 hours for off-loading unless other arrangements are made. When possible, the wall sections are erected directly from the trailers. Alternately, the wall sections are off-loaded by boom truck or forklift and stored near their final wall locations.

4. The wall sections are shipped to suit the erection sequence, when erected directly from the trailers. Otherwise, they are shipped in reverse sequence when the material is off-loaded, prior to erection.

5. The wall sections are erected using a boom truck. Scissors lifts or telescopic-boom lifts are used for the workmen.

6. For some projects, it may be possible to provide pre-assembled wall sections that are small and lightweight so that they can be lifted by hand, using 2 workmen.

7. The bracing is pre-erected prior to the wall erection or is erected as the wall erection proceeds. The bracing of pre-assembled wall sections usually involves a significant amount of material and labour, due to the height of the wall. The choice of bracing methods is selected to suit the availability of material and the project requirements.



2.4b Erection of Pre-assembled Wall Section

8. Approximately 90 lineal meters (300 lineal feet) of non-bearing wall, 9 m (30') high, can be erected and connected to steel framing or pre-erected bracing, with a crew of 6 men working for ten hours.















## 3. WALL MATERIALS

### 3.1 CONFORM® COMPONENTS














1. All of the CONFORM® components that are required for each project are indicated on the Shipping List and on the Erection Drawings. The various CONFORM components are identified in Figures 3.1 to 3.4.
2. The CONFORM components are precut to the required lengths, fabricated to suit the specific project requirements and labeled to match the erection drawings.
3. For walls that are over 6500 mm (21') high, the individual CONFORM components are split into two or more lengths. The joints in the alternating components are staggered near mid height. For pre-assembled wall sections, the staggered joint is typically 1500 mm (5') high and is not less than 900 mm (3'-0"). The horizontal joints in the CONFORM components do not affect the concrete pour and concrete remains monolithic. The joints are concealed with an architectural, 'multi-storey', band.
4. For large projects, CONFORM wall sections are pre-assembled at the manufacturing facility. The maximum width of pre-assembled sections is 2250 mm (7'- 4") to suit shipping and handling. The CONFORM components of a wall section are screwed together at the webs. For wall sections with staggered joints, the members are screwed together on the exterior face, at the staggered joints.
5. To avoid delays during erection, spare CONFORM components are ordered based on the project size, the project schedule, the site proximity to the manufacturing facility, the potential for damage on site and the potential for site modifications. The spare pieces include U250 universal box connectors, panels (P232, P182, P093), spacers (S068 and S049) and box joiners. The quantity and type of spare pieces are discussed with a NUFORM® representative to suit each specific project.



**FIG 3.1 CF4 COMPONENTS**  
**NOMINAL THICKNESS 4" -**  
**ACTUAL THICKNESS 3<sup>15</sup>/<sub>16</sub>" (100MM)**

Symbol	Components	Dimension	Label
<b>Box Components</b>			
	Straight	100mm 3 <sup>15</sup> / <sub>16</sub> "	BS
	End	100mm 3 <sup>15</sup> / <sub>16</sub> "	BE
	Corner	100mm 3 <sup>15</sup> / <sub>16</sub> "	BC
	3-Way	100mm 3 <sup>15</sup> / <sub>16</sub> "	BT
	4-Way	100mm 3 <sup>15</sup> / <sub>16</sub> "	BX
	45°	50mm 2"	BA
<b>Panel Components</b>			
	Panel 93	94.3mm 3 <sup>11</sup> / <sub>16</sub> "	PD
	Panel 182	183.3mm 7 <sup>3</sup> / <sub>16</sub> "	PH
	Panel 232	233.3mm 9 <sup>3</sup> / <sub>16</sub> "	PM
<b>Spacer Components</b>			
	Spacer 49	50mm 1 <sup>15</sup> / <sub>16</sub> "	SF
	Spacer 68	69.5mm 2 <sup>3</sup> / <sub>4</sub> "	SS
<b>Joiner Components</b>			
	Box Joiner	39mm 1 <sup>1</sup> / <sub>16</sub> "	JB
<b>Starter Components</b>			
	Starter	3mm 1/ <sub>8</sub> "	ST
<b>Opening Components</b>			
	Basic Frame Opening	3mm 1/ <sub>8</sub> "	BF

**FIG 3.2 CF6 COMPONENTS**  
**NOMINAL THICKNESS 6" -**  
**ACTUAL THICKNESS 5<sup>7</sup>/<sub>8</sub>" (150MM)**

Symbol	Components	Dimension	Label
<b>Universal U250</b>			
	Universal U250	250mm 9 <sup>7</sup> / <sub>8</sub> "	UN
<b>Box Components</b>			
	Straight	150mm 3 <sup>15</sup> / <sub>16</sub> "	BS
	Corner	50mm 5 <sup>7</sup> / <sub>8</sub> "	BC
	45° - Outside	100mm 1 <sup>15</sup> / <sub>16</sub> "	BA
<b>Panel Components</b>			
	Panel 93	94.3mm 3 <sup>11</sup> / <sub>16</sub> "	WP
	Panel 182	183.3mm 7 <sup>3</sup> / <sub>16</sub> "	WP
	Panel 232	233.3mm 9 <sup>3</sup> / <sub>16</sub> "	WP
<b>Spacer Components</b>			
	Spacer 49	50mm 1 <sup>15</sup> / <sub>16</sub> "	SF
	Spacer 68	69.5mm 2 <sup>3</sup> / <sub>4</sub> "	SS
	Curved Spacer 7.5°	89mm 3 <sup>1</sup> / <sub>2</sub> "	SC
<b>Joiner Components</b>			
	Box Joiner	39mm 1 <sup>1</sup> / <sub>16</sub> "	JB
<b>Starter Components</b>			
	Starter	3mm 1/ <sub>8</sub> "	ST
<b>Opening Components</b>			
	Basic Frame Opening	3mm 1/ <sub>8</sub> "	BF

**FIG 3.3 CF8 COMPONENTS**  
**NOMINAL THICKNESS 8" -**  
**ACTUAL THICKNESS 7<sup>7</sup>/<sub>8</sub>" (200MM)**

Symbol	Components	Dimension	Label	
<b>Universal U250</b>				
	Universal U250	250mm	9 <sup>7</sup> / <sub>8</sub> "	UN
<b>Box Components</b>				
	Straight	100mm	3 <sup>15</sup> / <sub>16</sub> "	BS
	Corner	200mm	7 <sup>7</sup> / <sub>8</sub> "	BC
	45° - Corner	50mm	1 <sup>15</sup> / <sub>16</sub> "	BA
<b>Panel Components</b>				
	Panel 93	94.3mm	3 <sup>11</sup> / <sub>16</sub> "	PD
	Panel 182	183.3mm	7 <sup>3</sup> / <sub>16</sub> "	PH
	Panel 232	233.3mm	9 <sup>3</sup> / <sub>16</sub> "	PM
<b>Spacer Components</b>				
	Spacer 49	50mm	1 <sup>15</sup> / <sub>16</sub> "	SF
	Spacer 68	69.5mm	2 <sup>3</sup> / <sub>4</sub> "	SS
<b>Starter Components</b>				
	Starter	3mm	1/8"	ST
<b>Opening Components</b>				
	Basic Frame Opening	3mm	1/8"	BF

**CONFORM ACCESSORY COMPONENTS**

<b>Electrical Raceway</b>				
	Low Voltage Electrical Raceway	-	-	EC
<b>Multi-Story Band</b>				
	Multi-Storey Cap	155mm x 9mm	6 <sup>1</sup> / <sub>8</sub> " x 3/8"	-
	Multi-Storey Channel Cap	-	-	-
	Multi-Storey Channel Cap Cover	155mm x 9mm	6 <sup>1</sup> / <sub>8</sub> " x 3/8"	-

**FIG 3.4 CF8i COMPONENTS**  
**NOMINAL THICKNESS 8" -**  
**ACTUAL THICKNESS 7<sup>7</sup>/<sub>8</sub>" (200MM)**

Symbol	Components	Dimension	Label	
<b>Universal U250</b>				
	Universal U250	250mm	9 <sup>7</sup> / <sub>8</sub> "	UN
<b>Box Components</b>				
	Straight	100mm	3 <sup>15</sup> / <sub>16</sub> "	BS
	Outside Corner	200mm	7 <sup>7</sup> / <sub>8</sub> "	BC
	Inside Corner	200mm	7 <sup>7</sup> / <sub>8</sub> "	BC
	45° - Outside	50mm	1 <sup>15</sup> / <sub>16</sub> "	BC
<b>Panel Components</b>				
	Panel 93	94.3mm	3 <sup>11</sup> / <sub>16</sub> "	PD
	Panel 182	183.3mm	7 <sup>3</sup> / <sub>16</sub> "	PH
	Panel 232	233.3mm	9 <sup>3</sup> / <sub>16</sub> "	PM
<b>Spacer Components</b>				
	Spacer 49	50mm	1 <sup>15</sup> / <sub>16</sub> "	SF
	Spacer 68	69.5mm	2 <sup>3</sup> / <sub>4</sub> "	SS
<b>Starter Components</b>				
	Starter	3mm	1/8"	ST
<b>Opening Components</b>				
	Basic Frame Opening	3mm	1/8"	BF

### 3.2 CONCRETE MIX

1. The specified 28 day compressive strength of the concrete is determined by the structural engineer for the project.
2. The concrete mix proportions and the types of aggregates are selected to meet the specified strength and to provide a workability that allows the mix to flow through the coring without vibration. The workability is dependent on the cement content, the aggregate size and shape, the water content and the weather conditions during placement.
3. The following mix specification is recommended to meet the workability requirement:
  - Specified compressive strength at 28-day of 20 MPa (3000 psi) minimum or 25 MPa (3500 psi) for freeze-thaw conditions
  - Water to cement ratio of 0.55 maximum. This may provide more cement than required for strength but the high cement content is required for workability.
  - Maximum aggregate size of 10 mm (3/8") rounded stone such as pea gravel
  - Minimum slump of 100 mm-125 mm (4"-5") at the point of discharge. Approximately 150 mm (6") at the truck.
  - Water reducing admixture
  - Air entrainment of 5-7% for freeze-thaw conditions, when applicable
4. To achieve the high slump and desired flow, the mix will have a high cement content and in many cases higher than is required for the specified compressive strength. For heavily reinforced walls, the slump may have to be slightly higher to ensure that the concrete is in full contact with the reinforcing steel bars in areas of congestion, such as in corners with hooked bars and in lintels with more than one layer of horizontal reinforcing steel.
5. The use of fly ash is not recommended since it tends to create a concrete mix that adheres to the inside of the CONFORM components and results in a poor concrete flow.
6. The use of plasticizers or super-plasticizers in the concrete mix is not recommended. Often, it is necessary to place the concrete at a slow pace and the time constraint of a plasticizer may not be suitable and may result in poor flowing concrete and poor consolidation.
7. The concrete does not segregate when placed in CONFORM due to the inner webs of the box connectors and panel components, which form small cells that act like individual "elephant trunks" and prevent the "free-fall" of heavier aggregates.
8. The fluid pressure on the face of the CONFORM components is significantly less than that experienced with conventional formwork. The large number of inner webs and coring create a bridging action and the numerous joints between the components relieve the pressure by bleeding the water and cement paste.
9. Internal mechanical vibrators are not recommended for use with CONFORM since this may cause the faces of the CONFORM components to bow and bulge. To ensure that there are no voids and that the concrete is well consolidated, the face of the CONFORM components is externally vibrated by tapping with rubber mallets or by applying external mechanical vibrators.
10. The quantity of concrete is calculated based on the wall area and is adjusted for wall openings, wastage and specific project conditions. The theoretical quantities of concrete for walls with CONFORM are shown in Table 3.1 (Metric units) and Table 3.2. (Imperial units).

**TABLE 3.1: CONCRETE TAKE-OFF (METRIC UNITS)**

	CF4	CF6	CF8	CF8i
	<b>Square Metre of Wall Area</b>			
Per Cubic Metre of Concrete	11.1 m <sup>2</sup>	7.2 m <sup>2</sup>	5.4 m <sup>2</sup>	7.5 m <sup>2</sup>
	<b>Cubic Metre of Concrete</b>			
Per Square Metre of Wall Area	0.0903 m <sup>3</sup>	0.1385 m <sup>3</sup>	0.1867 m <sup>3</sup>	0.1336 m <sup>3</sup>

**TABLE 3.2: CONCRETE TAKE-OFF (IMPERIAL UNITS)**

	CF4	CF6	CF8	CF8i
	<b>Square Foot of Wall Area</b>			
Per Cubic Yard of Concrete	91 ft <sup>2</sup>	59 ft <sup>2</sup>	44 ft <sup>2</sup>	61 ft <sup>2</sup>
	<b>Cubic Yard of Concrete</b>			
Per Square Foot of Wall Area	0.0110 yd <sup>3</sup>	0.0169 yd <sup>3</sup>	0.0227 yd <sup>3</sup>	0.0164 yd <sup>3</sup>

### 3.3 STEEL REINFORCING BARS

1. The size and spacing of steel reinforcing bars are selected by the structural engineer for each project to suit the specific structural requirements.
2. The spacing of the vertical reinforcing steel is selected to suit the spacing of the CONFORM components, which are based on a 1000 mm (3'-4") grid. A bar spacing of 167, 250, 333 and 500 mm (6-1/2", 10", 13" and 20") are common.
3. The vertical bars are placed the full height of the wall.

4. The vertical bars are 15M (#5) or larger in order to maintain a straight and plumb bar within the wall. Typically, the vertical bars are placed in the center cell of the U250 universal component or the center of box connectors.

5. Wire hoops are tied with 16 ga. wire or tack-welded to each vertical bar in order to locate the bars at the specified location from the face of the wall. The wire hoops are placed at 600 mm (2') from each end and at 3000 mm (10') on center maximum, with a minimum of two hoops per bar.



3.3 Vertical Rebar with Hoop

6. The spacing of the horizontal reinforcing steel is selected to suit the spacing of the coring in the webs of the CONFORM components, which is at 83.3 mm (3-1/4") on center. A bar spacing of 250, 333, 416 and 500 mm (10", 13", 16" and 20") is common.
7. Typically, the horizontal bars are placed in lengths up to 5500 mm (18') and are installed with laps, as specified on the structural drawings.
8. The horizontal bars are placed through the coring in the webs of the CONFORM components and are installed after the vertical bars are placed.

9. Conventional 'L' bars cannot be installed at corners and intersections of walls with CONFORM. Therefore, 180° hooked horizontal bars must be installed and a vertical bar must be placed through the overlapping hooks.

10. The 180° hooks for horizontal bars are bent using the pin diameters used for stirrups and ties. The 180° hooks must fit through the coring in the webs of the CONFORM components. Refer to the CONFORM Engineering Guide ([https://www.nuformdirect.com/wp-content/uploads/Engineering\\_Guide\\_v2.0.pdf](https://www.nuformdirect.com/wp-content/uploads/Engineering_Guide_v2.0.pdf)).

11. Where 'L' bars are essential at the corners, they can be installed by using a threaded mechanical splice at the bend of the 'L' bar.

### 3.4 FASTENERS, BRACING, OTHERS

1. The required fasteners depend on the specific project and may include:
  - Fasteners for CONFORM components
  - 1-1/2" Common Nails (for formwork plywood)
  - 3" Double Headed Nails (for bracing and forming lumber)
  - 3" Common Nails (for bracing and forming lumber)

2. The required bracing materials depend on the erection and bracing methods selected for the specific project and may include:

- Nominal 2x4, 2x6, 2x8, 2x10 and 4x4 Framing Lumber (for bracing and formwork)
- 1/2" OSB Sheathing (for formwork)
- 3/4" Rough Spruce or Pine Plywood Sheathing (for formwork)
- Form Brace Aligners (for rakers)
- Slotted Steel Channels and Fittings (for small projects)
- Cold Formed Steel Angle 2"x2"x18 ga (for small projects)
- Steel Angle 3x2x3/16" (for large projects)
- Bakers Scaffold w/Wheels (for erection of small projects)
- Heavy Duty Scaffolding (for erection and shoring of large projects)
- I Beams (for shoring of large projects)
- Post Jacks (for shoring of large projects)

3. The other items that may be required for a specific project include:

- Cleaners and Patching Materials (refer to Section 13 and 14)
- Paints and Cladding Materials (refer to Section 15)
- Oxime Neutral Cure Silicone Sealant (refer to Section 13)
- Wire Hoops and Tie Wire
- AIFB (Ten-test)
- Polystyrene or Polyurethane Insulation Boards (to form pockets and expansion joints)
- Foundation Drainage Mat
- Miscellaneous Construction Materials

## 4. EQUIPMENT

### 4.1 HAND TOOLS

1. The hand tools used on most projects:
  - Measuring Tapes (7.5 m/25') and (30 m/100')
  - 100' Chalk Reel & Chalk
  - 48" Aluminum Hand Level
  - 16" x 24" Carpenter's Square
  - 20 oz Claw Hammers
  - 28 oz White Rubber Mallets
  - 10 lb or 20 lb Sledge Hammer
  - Utility Knife and Blades
  - Hack Saw and Blades
  - 24" Carpenter's Hand Saw (Crosscut, 10 TPI)
  - Screwdriver Sets (Slot, Phillips, Robertson)
  - 3/4" x 8" Concrete Chisel
  - 7" Wire Cutters
  - 8" Linesman Pliers
  - 12" Adjustable Wrench
  - 8" Aluminum Hand Trowel
  - Caulking gun
2. The additional hand tools used for small projects:
  - Plumb Bob
  - Mason String Line
  - 12" Combination Square
  - 4 in 1 Carpenter's File
  - Wood Chisel Set (1/4", 1/2", 3/4", 1")
  - Carpenter's Block Plane
  - 9-3/4" Straight Metal Snips
  - 10" Vice Grips
  - 24" Bar Clamps or Quick-Grip Clamps
  - Rivet Gun (1/8"Ø x 1/2" aluminum rivets)
3. The additional hand tools used for large projects:
  - Surveyor's Level
  - Surveyor's Laser Transit
  - 20"x 14" Carpenter's Clamps
  - 3/8" x 100' Rope

### 4.2 POWER TOOLS

1. The power tools required on most projects:
  - 3/8" Cordless Drill Kits and Spare Batteries (14.4V min.)
  - Extension Cords and Power Bars
  - 1/2" Electric Impact Drill
  - HSS Drill Bits (1/16"Ø to 1/2"Ø)
  - Magnetic, 6" Round Shaft, Driver Bits (Phillips, Robertson #1 & #2, Socket)
  - Hole Saw Kit (3/4"Ø to 2-1/2"Ø)
  - 1-1/2" Rotary Hammer Drill (for dowels)
  - Concrete Drill Bits (5/32", 3/16", 3/4", 1")
  - Heat Gun
  - 7-1/4" or 8" Circular Saw (60 Teeth Blades)
  - Reciprocating Saw (14 TPI x 8" Blades)
  - 4-1/2" or 5" Grinder (grinding discs)
  - 12" or 14" Gas Powered Quick Cut Saw (Metal & Concrete Blades)
  - 3000 psi Power Washer (with heater for hot water in winter)
  - Gas Powered Generator (2500 watt)
  - Jig Saw (18 TPI Blades)
  - 10" or 12" Sliding Compound Mitre Saw (with 72 Teeth blades)

### 4.3 ERECTION EQUIPMENT

1. The erection equipment used on most projects:

- Aluminum Step Ladders (4', 8' or 12')
- Baker's Scaffold or Aluminum Scaffold
- Concrete Funnel (CF4, CF6, CF8/8i)
- Concrete Bucket (1/2 yard)
- Push Brooms and Corn Brooms
- 6' Scraper
- Square Shovel
- Wheelbarrow
- Soft Bristle Brushes for Washing
- 100' Garden Hose with Spray Nozzle

2. The additional erection equipment used for large projects:

- Surveyor's Laser Transit for Vertical Line
- Extension Ladder (20' or 30')
- 3/8" x 250' Rope
- Strapping Equipment and Strapping Refills
- Lifting Bar (15/16"Ø x 9' smooth bar)
- Lifting Chains (2 hooks and 8' chains)

### 4.4 CONSTRUCTION EQUIPMENT

1. The construction equipment used on most projects:

- 34 m Concrete Pump with 3" or 4" reducer and S-bend

2. The additional construction equipment used for large projects:

- Scissors Lift (40' platform)
- Telescopic-Boom Lift (60' arm) or a second Scissors Lift
- Telescopic Fork Lift (40' arm)
- Boom Truck (1200 lb capacity at 70')
- MIG Welder with electrodes, mask and gloves

## 5. SAFETY

### 5.1 WORKMEN

1. All workmen must follow the applicable construction safety rules and regulations to operate all equipment and tools and to perform all work.
2. Workmen shall not travel or work below any wall sections or components that are lifted overhead by a boom truck or workmen.
3. Workmen must wear construction gloves to handle the CONFORM® material. The edges of the coring and the ends of the components are hazardous.
4. The components must not be held through the coring when slid together. The coring in the webs creates a sharp shear as the components are slid together and can cause serious injury.
5. Workmen working off the ground or on elevated platforms must wear the appropriate safety harnesses.

### 5.2 WEATHER CONDITIONS

1. The CONFORM components are not affected by weather conditions. However, long components or pre-assembled panels are not erected in adverse weather conditions for safety reasons. Short walls and sill walls may be erected in most weather conditions.
2. CONFORM must not be erected in high winds since the components and wall sections cannot be handled safely by the workmen.
3. The walls are not erected in icy or snowy conditions where the workmen have poor footing conditions.
4. The appropriate lateral bracing for stability and wind conditions must be installed as the CONFORM components are erected. The lateral bracing must remain in place until the concrete is cured and the permanent bracing or structural framing is attached.



5.1 Bearing Wall Project



## 6. SITE PREPARATIONS

### 6.1 SITE GRADING AND ACCESS

1. The ground at the exterior and interior of the building is graded to a level surface for equipment access during erection of the walls. Typically, the ground is graded to the finished sub-base elevation specified for the exterior paving and the interior floor slab, but not higher than 150 mm (6") below the top of the foundation wall or footings.

2. Depending on the method of erection, individual component or pre-assembled wall sections, the ground may have to be graded level for at least 6 m (20') wide at the exterior and interior side of the foundation wall. In the case of preassembled walls, it is recommended that the width at the exterior side of the foundation wall be 15 m (50'). This is to allow 4.5 m (15') for a scissors lift or telescopic boom lift, 6 m (20') for a boom truck to lift the panels and 4.5 m (15 ft) for trucks to deliver the panels.

### 6.2 STORAGE OF MATERIAL

1. A secure area is required on site for storage of all material and equipment. The size of the area depends on the size of the project, the delivery schedule for material and the equipment being used for erection. The storage is selected to keep the components as clean as possible. If the grooves of the panels become dirty, the components will not slide together easily.

2. Care is taken to avoid damaging the finished surface of the CONFORM® components. Individual components are stacked on their edges (cored side down) to prevent damage and scratches to the finished faces. The components are never stored on the finished faces and components are never dragged on their faces or dragged over the face of another component.

3. The labeling is noted during off-loading and similar components are stacked together. When practical, a separate pile is created for each different length of each different individual component and the labels are placed at the same end. The piles are placed in close proximity to the area where the material will be installed. The labels are placed at the top of the components and for flat walls the first hole of the coring is 37 mm (1-1/2") from the top end.

4. The individual components are stacked in a level configuration, one on top of the other. The components are placed on leveled wood sleepers that are spaced at 1.5m (5') on center, maximum. The components have a tendency to deform if they are stored with uneven or insufficient support. The flat straight piles do not exceed than 1200 mm (4') high by 1200 mm (4') wide and the piles are braced for stability.



6.2a Storage of Individual Components

5. When daily temperatures are consistently over 30°C (86°F), the material should be stored in the shade or covered with loose tarps that provide shade but do not restrict the air flow. CONFORM material must not be stored in closed containers or tightly wrapped with tarps or plastic wrap, since this will increase temperatures and may result in deformation of the components.

6. The pre-assembled wall sections are shipped on open trailers and are erected directly from the trailers (flat beds) or are off-loaded. In either case, the material must be delivered and stored around the building within reach of the boom truck and stacked to suit the sequence of wall erection, in order to minimize handling of the material.



7. The pre-assembled wall sections must be protected at the lower bottom edge to prevent scratches to the face of the wall section below as they are lifted for erection with a boom truck.

8. In the case of multi-level buildings, a storage and work area at least 3 m (10') wide is required around the perimeter of each level. The loose material is shipped on skids and the skids are lifted to the upper level as required.

9. The material is checked with the shipping list and any discrepancies are reported immediately to Nuform Building Technologies (1-877-747-9255).

10. All spare materials and spare CONFORM components are identified and stored separately. When spare CONFORM components are placed in a wall, the pieces are oriented to ensure that the coring is aligned.

### 6.3 FOUNDATIONS

1. All footings, foundation walls and foundation slabs are constructed prior

to starting the erection of the CONFORM components.

2. The foundations are straight and within 6 mm (1/4") of the locations specified on the CONFORM layout drawing and must take into account any adjustments for thermal expansion and contraction of the CONFORM components. Refer to Construction Bulletin #1 (<https://www.nuformdirect.com/wp-content/uploads/Construction-Bulletin-01-Building-Layout.pdf>).

3. The tops of the foundations are finished with a wood float and are level  $\pm 3$ mm in 3000 mm (1/8" in 10') and within 6 mm (1/4") of the specified elevation.

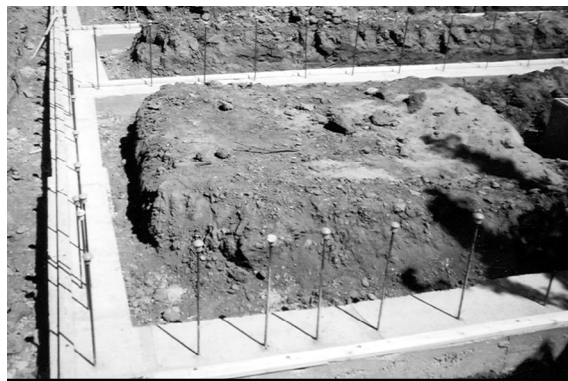
4. A drainage chamfer where specified at the edge of foundations is provided.

5. The foundations are clean of debris and loose concrete.

### 6.4 WALL DOWELS

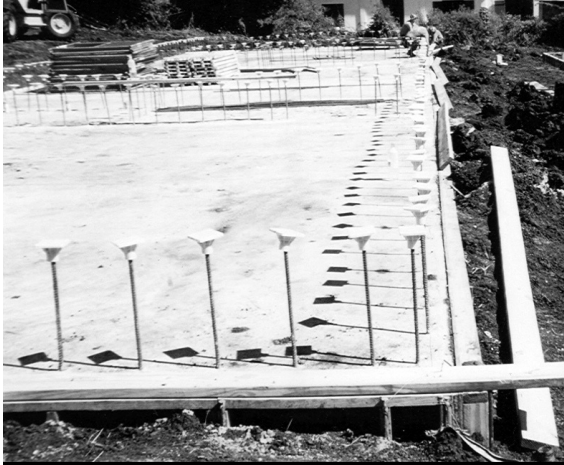
1. Dowels are installed during the construction of the foundations, in accordance with the structural drawings.

2. For footings and foundation walls, the dowels are either tied in place prior to pouring the concrete for the foundations or placed in the concrete as the foundations are poured. Dowels that are missing or incorrectly located are site-drilled and grouted into the foundations, as specified by the structural engineer.



6.4a Footings with Dowels

3. For monolithic foundation and floor slabs, the dowels are placed in holes that are drilled into the slab and filled with epoxy or cementitious grout, as specified by the structural engineer.



6.4b Foundation Slab with Dowels

4. The dowels are located accurately to suit the CONFORM components. The dowels are placed within 20 mm (3/4") of the center of each component in order to avoid interference with the webs of the CONFORM components.

5. The locations of the dowels at each side of door openings are critical and must be accurately located.

## 6.5 UNDERGROUND SERVICES

1. All underground and in-slab plumbing is installed prior to pouring the foundation slab.
2. All underground and in-slab electrical wiring is installed prior to pouring the foundation slab. Electrical conduit is installed below the foundation slab to suit the distribution of wiring to the walls or CONFORM service channels.

## 6.6 ELECTRICAL POWER

1. Hand tools for workmen are battery operated whenever possible.
2. Portable generators are recommended for site power in order to provide accessibility at all locations and to minimize the length of extension cords.

## 6.7 WATER SUPPLY

1. A water supply, hoses and washing nozzles are required for cleaning the walls during concrete placement.
2. A power washer is recommended to clean the walls with a pressure of 3000 psi.
3. For small projects, the power washer is connected to a water tap and for large projects it is connected to a water truck.
4. Hot water is used in cold weather construction.

# 7. WALL ERECTION - GENERAL

## 7.1 ORIENTATION

1. **CONFORM® is a pre-finished concrete wall formwork. Additional painting or veneers are not required. CONFORM material is handled and treated as a "pre-finished" product to avoid unnecessary damage or marring of the surface or the components.**

2. The CONFORM components are pre-cut to length as required for each project. However, some components may need to be site cut if there are field changes to suit site conditions, or to revise the openings for door and windows.

3. Experienced concrete or formwork installers are trained to become familiar with the various CONFORM components and the labeling system used on the CONFORM assembly drawings. Each component is specifically labeled for a location within the wall. During erection, one person is assigned to locate and coordinate the components or wall sections consecutively, in accordance with the CONFORM erection drawings.

**4. CONFORM components are installed with the “labeled end” up. This allows verification during assembly of the component locations and also maintains the alignment of coring for proper flow of concrete between the components. Assembling a component upside-down will cause the coring to be mis-aligned and concrete will not flow properly between the wall components.**

5. The component sequence and orientation is checked and re-checked throughout the assembly. The removal and re-assembly of wall components due to incorrect sequence or orientation can significantly delay the erection.

**6. The CONFORM components must be visually inspected for damage or breaks to the web between the coring. Any CONFORM components with a broken web must be replaced or repaired, since the webs hold the two faces of the wall together during placement of concrete. Damage or a fracture of a web will result in a bulge in the wall face and damage to two or three webs can result in a blowout.**

7. During extremely cold temperatures, avoid dropping the CONFORM components as fractures to the ends and breaks in the webs may occur.

8. Bracing is required to hold the top and bottom of the wall as the components are assembled. For high walls, additional bracing is required at mid-height. Refer to the bracing section to ensure proper materials are on-site before starting the wall erection.

9. The installation of CONFORM components requires a foundation or floor by others. The foundation must have the required reinforcing dowels accurately located in accordance with the structural drawings and the CONFORM drawings.

## 7.2 LAYOUT

1. The dimensions of the foundation and square of the foundation are verified with respect to the CONFORM layout drawings, including any adjustments for thermal expansion and contraction. Refer to Construction Bulletin #1. [nuformdirect.com/wp-content/uploads/Construction-Bulletin-01-Building-Layout.pdf](http://nuformdirect.com/wp-content/uploads/Construction-Bulletin-01-Building-Layout.pdf)



2. The elevation and levelness of the top of the foundation are verified to ensure that the foundations are suitable for CONFORM and that elevation changes are provided where specified.

3. The location of one face of each wall is measured as accurately as possible, + 3 mm (+ 1/8"), and marked on the top of the foundation using a chalk line. All measurements along a wall are taken cumulatively from one corner in order to obtain accurate locations. A 3:4:5 triangle is used to ensure that corners are square. Where possible, the diagonals are measured from corner to corner and made equal to ensure the layout is square.

4. Each side of all openings is measured and marked on the top of the foundation.

5. Prior to starting the wall erection, strapping is provided flush with the face of the wall along the entire perimeter of the chalk line using steel angles or wood members that are anchored to the foundation every 400 to 600 mm (16" to 24") on center.



7.2 Metal Strapping and Dowels

6. The locations of dowels are checked as indicated on the drawings. Any missing or mislocated dowels are corrected.

### 7.3 ERECTION PROCEDURE

1. Typically, an erection crew is composed of 6 workmen and a foreman. In addition, truck drivers, mobile crane operator and a concrete pump operator are required. It is recommended that a NUFORM® representative be on site during initial projects, to provide technical assistance.

2. Any ice or snow on top of the foundation walls is removed prior to erecting the walls, using brooms or propane heaters.

3. Erection of CONFORM components usually starts at a corner. Several components of a wall section are erected at each side of the corner. The corner is braced and checked to ensure that it is plumb prior to proceeding.

4. Erection proceeds along one wall to the next corner by sliding adjacent components or wall sections together. The components or wall sections are placed tight to the strapping on the foundation and are braced at the top and bottom as they are erected.

5. The appropriate universal, box connectors, panels and other components are installed according to the CONFORM layout drawings.

6. The plumb of the wall face and the joints between components are monitored as the wall is erected. The plumb of previously erected walls is verified at the start of each day prior to continuing with the erection since temperature changes can affect the established plumb lines due to thermal expansion.

7. If the erected portion of a wall is not plumb after the erection of several meters, it will be necessary to push or pull the components or wall sections as they are erected to re-establish plumb wall joints.

8. If a large portion of a wall is found to be not plumb, after erection, it may be necessary to remove and reinstall part of the wall. It may be possible to adjust the plumb using the bracing or using heavy equipment to push the wall at the corners.

9. For speedier erection, form aligners with turnbuckles are used on the rakers. Initially, the face of the wall is plumbed with a four foot carpenter's level to within + 25 mm (+1") of plumb at the top of the wall. After a complete building face or wall is erected, the wall is set plumb and straight within 3 mm in 3000 mm (1/8" in 10') using a laser level or a string line from corner to corner and adjusting the form aligners. The string line may be left in place to verify that the walls remain straight during the concrete placement.



10. The cleanliness of the components and especially the legs and panel grooves will affect the sliding of the panels. The components are kept clean and any obvious dirt wiped away.

11. If difficulty is encountered in sliding the components, the joints are lubricated by spraying the leg or groove with a silicone lubricant or a vinyl protectant (such as Armor-All). If the components are difficult to slide, they are hit at the top with a sledge hammer or a demolition gun but using a wood block to protect the end of the component. Excessive force must not be used with the hammer or the components will break or chip. Use sufficient force to achieve a 25 mm to 50 mm (1" to 2") drop per blow. Also, refer to Construction Bulletin #2 (<https://www.nuformdirect.com/wp-content/uploads/Construction-Bulletin-02-Sliding-of-Components.pdf>).



## 7.4 WALL LENGTH

1. The CONFORM components have a tolerance of 0.5 mm (1/32") at each joint but this varies depending on the temperature, the straightness of the components, the height of the wall and the type of component.
2. Due to the large number of joints, this tolerance allows the length of the wall to be adjusted by pushing and pulling on the components as they are erected. In this manner it is possible to keep the wall length close to the specified length indicated on the CONFORM drawings and to keep the joints plumb. Tapping or shaking the bottom of the wall will aid in adjusting the wall length.
3. High temperatures or low temperatures affect the horizontal length of the walls. The theoretical wall length will vary 2.9 mm in 5000 mm for each 10°C (1/8" in 16' for each 20°F) variation in temperature. The theoretical dimensions on the CONFORM drawings are calculated at 20°C (68°F).
4. When the erection is within approximately 1.5 m (5') of a corner or a large opening, the wall length remaining is measured at the top and bottom of the wall and verified with the supplied components or wall sections. Metric dimensions are used to determine the acceptability of the remaining components since the imperial dimensions for components are rounded to the nearest fraction. The wall is plumbed if the top and bottom dimensions are not equal.

5. The components or wall sections are adjusted adjacent to a corner or a large opening, using spacers and small panels to suit the required dimension. Refer to Construction Bulletin #3 (<https://www.nuformdirect.com/wp-content/uploads/Construction-Bulletin-03-Wall-Dimensions.pdf>) to determine the components required to suit a specific dimension.



## 7.5 STARTERS

1. Starters are used to create T-intersections except for the CF4 wall. Refer to Construction Bulletin #15 (<https://www.nuformdirect.com/wp-content/uploads/Construction-Bulletin-15-Starter-Installation.pdf>).



2. Usually, starters are assembled to the adjacent components, prior to starting the wall erection. A starter is oriented on the adjacent components so that the coring holes will be aligned.

3. The web of the starter is connected to the face of the adjacent components with 1/8"  $\varnothing$  x 1/2" long aluminum pop rivets. The pop rivets are located 20 mm (3/4") from each side of the starter and centered between each second coring hole, at 167 mm (6-5/8") on center.

4. Holes are cut in the face of the adjacent component to match the coring holes in the starter.



5. Alternately, the starter is temporarily held in place in order to cut the coring holes in the face of the adjacent component. Then, the starter is slid onto the next panel and both the starter and the panel connected to the adjacent component, by reaching through the coring to install #10 x 3/4" screws, at the same spacing specified for pop rivets.

## 7.6 DOORS, WINDOWS, OPENINGS

1. CONFORM is installed to one side of a wall opening. The sill components are installed and the first 2 or 3 components or wall section at the other side of the wall openings are installed. The coring is checked to ensure that it is aligned.

2. At door openings, temporary wood blocking is anchored to the foundations at each side of the opening to maintain the correct opening width and location.

3. All horizontal steel reinforcing bars that are required adjacent to an opening must be placed in the wall prior to installing door frames.

4. Wrap-around hollow metal frames, if required, are installed before the header above the opening.

5. Steel overhead door frames, if required, are erected prior to starting the erection of CONFORM. The frames are anchored to the foundations and held in place with temporary steel or wood bracing.



7.6a Overhead Door Frame Installation

6. When steel lintels are specified, a “cut out” to match the lintel shape is site cut into the web of the box or panel adjacent to the opening. The height for the underside of the steel lintel can be determined by temporarily installing a component from the header and scribing a line on the web at each side of the opening. The lintel is lifted into position and inserted into the “cut-out” in the two side components. The header components are pre-fabricated to suit the lintel, if requested.

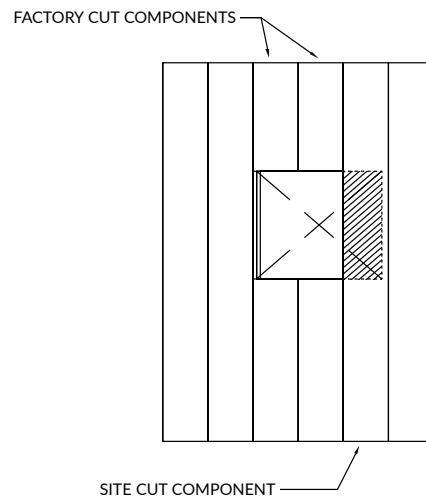


7.6b Steel lintel Installation

7. The header components are pre-assembled and the webs are connected together. The header is installed between the two side components and is held in place by screwing the webs at the ends of the header to the webs of the side components. For large headers, at least one T-support is provided initially, until the temporary bracing is installed to support the weight of wet concrete to be placed in the header.

8. If you received your material as “Site Cut” it will be necessary to cut the components on either side of the opening to achieve the correct opening size.

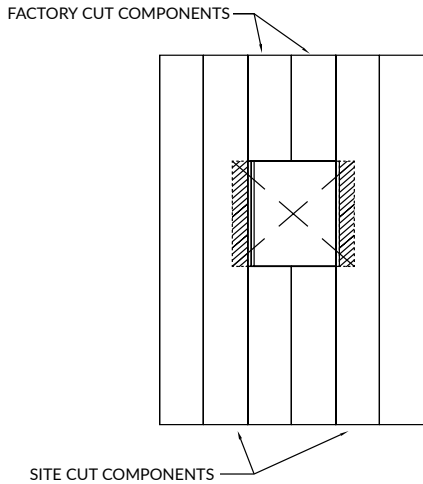
Identify the location of the opening in the wall. If the project permits, move the location of the openings to the left or right, without changing the required opening width as shown in Figure 7.6c. Depending on the size of the opening, this may reduce the amount of site work that is necessary as only one panel needs to be cut (hatched portion).



7.6c One Component Site Cut

If the location of the openings cannot be altered due to project constraints, then it will be necessary to cut one panel on each side of the opening to achieve the correct opening size. See Figure 7.6d





7.6d Two Site Cut Components

Once the location of the openings is determined, proceed to cut the CONFORM components on either side as required using a jig saw or circular saw (hatched portion). Alternatively, you can use an oscillating saw or an angle grinder.

Refer to Construction Bulletin No. 20 for additional bracing and flashing details. [nuformdirect.com/resources/conform-bulletins/](http://nuformdirect.com/resources/conform-bulletins/)



9. Horizontal reinforcing bars in the header are installed from one end, after the header is in place. Alternately, they are spliced and installed in the header before it is erected and the bars are moved each way into the adjacent walls leaving an appropriate lap in the header.

10. Bracing is installed for the opening and frames to maintain the dimensions, plumb and square of the opening during placement of concrete.

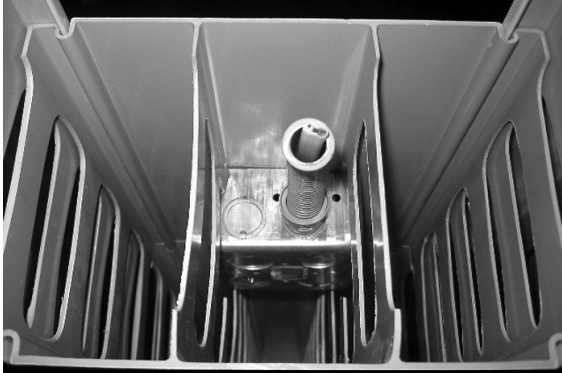


11. Conventional hollow metal door frames or wood door frames are installed in openings that are formed with CONFORM. The CONFORM components are selected to provide openings that suit the specified frames.

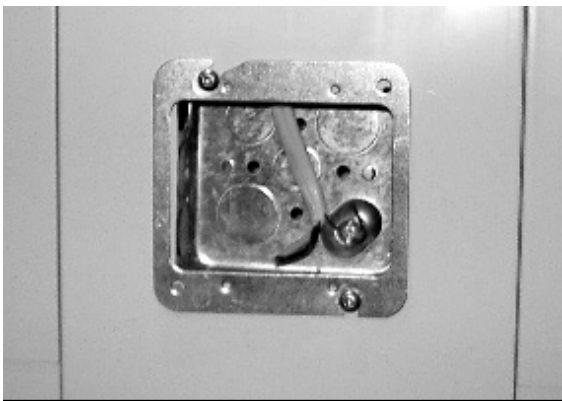
12. Large mechanical openings are planned and the CONFORM components are pre-cut to suit the opening. Small mechanical openings and sleeves are site cut into CONFORM components. All openings are formed and braced. Alternately, openings and sleeves can be site cut or drilled through the wall after the concrete is poured.

## 7.7 ELECTRICAL

1. For conventional electrical wiring, masonry electrical boxes and rigid or flexible conduit are installed in the components as the wall is erected.

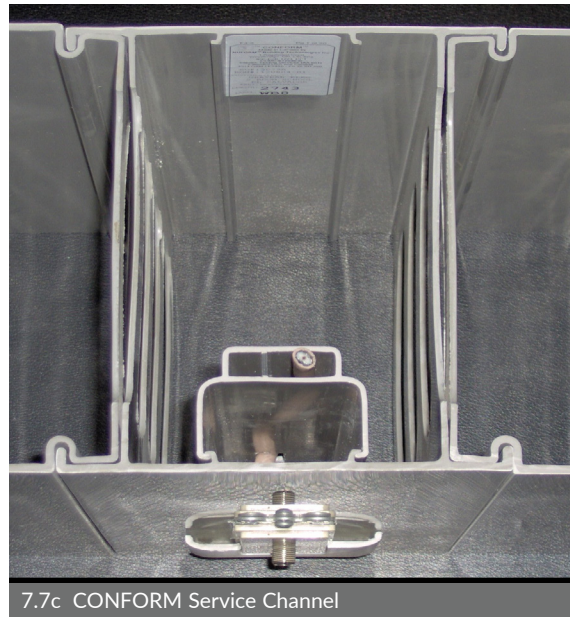


7.7a Electrical Box and Conduit



7.7b Electrical Box Installation

2. A CONFORM non-metallic service channel is used for low voltage wiring and communication cables. The locations of all service channels are pre-determined and noted on the CONFORM erection drawings. During erection, service channels are installed in the component with receiving legs or using the channel adapter. The channels are full height and the tops of the channels are sealed with duct tape. The channels are checked to ensure they are sealed during the concrete placement. The locations of the channels are marked on the face of the component with tape, for future reference.



7.7c CONFORM Service Channel

3. For industrial projects, the electrical boxes and wiring are surface mounted in the same manner as conventional concrete or masonry walls.

## 8. WALL ERECTION - INDIVIDUAL COMPONENTS

### 8.1 ERECTION PROCEDURE

1. The individual components have a distinctive top and bottom orientation, which must be maintained in order for the coring to be aligned. Typically on flat cut walls, the top of the first coring hole is 37 mm (1-1/2") from the top of the wall. During erection the top of the components must be identified to ensure that all coring is aligned within 10 mm (3/8").

2. The individual components are erected sequentially by two workmen, one working on the ground and one working on a scaffold or man-lift. The first panel is placed on the foundation and each subsequent component is lifted to the top with the connector leg of the component is aligned with the grooves of the adjacent component and slid to the bottom.

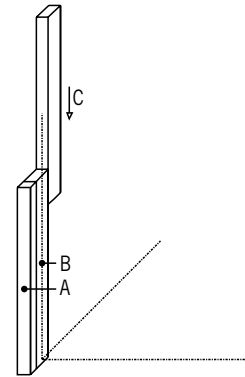


8.1 Erection of CONFORM® Components

3. The installation of the last component between two parts of a wall can be made easier by lifting one of the adjacent components, approximately 900 mm (3'). One side of the last component is slid onto the lifted component and the other side of the last component is connected to the wall by pulling or pushing on the end of the last component. Then, the last component and the adjacent component are slid down to the foundations.

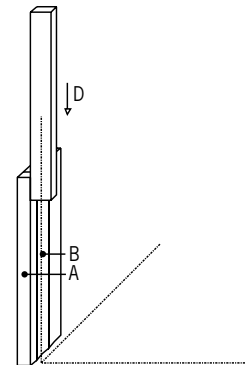
### 8.2 ERECTION SEQUENCE

1. Erection is started at a corner or a T-intersection with several components installed as per diagram 8.2a



8.2a Erection of CONFORM® Components

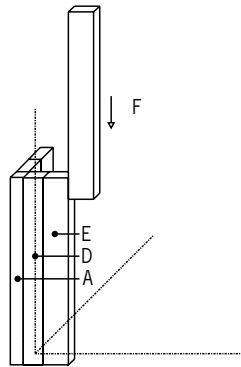
2. The first panel component is installed into the corner box as per diagram 8.2b.



8.2b Erection of CONFORM® Components

3. The pieces are checked to ensure that the correct components are installed and properly oriented and that the coring is aligned.

4. Additional components are added at each side of the corner or T-intersection for a distance of 667 mm (2' 2") as per diagram 8.2c.



8.2c Erection of CONFORM® Components

5. Bracing is provided at the top and bottom of the corner or T-intersection assembly and the components are screwed together at the top after the assembly is accurately plumbed.

6. The erection of CONFORM components is continued sequentially, in accordance with the CONFORM layout drawings, including the components for doors, windows and openings.



8.2d Erection of CONFORM® Components

7. The wall erection is continually monitored to ensure the correct component sequence and alignment of coring.

8. Measurements are taken along the length of the wall to ensure that the dimensions are maintained in accordance with the CONFORM drawings. The components are pulled or pushed together as the erection proceeds to ensure the specified dimensions are achieved.

9. Temporary bracing and steel reinforcing bars are installed as the wall erection proceeds.

10. If horizontal hooked corner bars are required, refer to Section 10, Steel Reinforcing Placement, for the erection of corners and intersections.

11. The other corners and T- intersections are precisely located to suit the CONFORM layout. As the erection is completed at a corner or T-intersection, the wall is pushed or pulled to ensure that the corner or T-intersection is at the correct location.

# 9. WALL ERECTION - PRE-ASSEMBLED WALL SECTIONS

## 9.1 ERECTION PROCEDURE - LOW WALLS

1. Typically, the pre-assembled wall sections are erected using an overhead crane with a capacity to lift a full wall section to the top of the wall, so that the wall section is slid into place using its own weight.
2. An erection crew is composed of 5 workmen and a foreman. In addition, a crane operator and truck drivers are required. During lifting, two workmen are required to hold ropes at the base of the wall sections. Two workmen are required on scissor lifts or telescopic lifts to guide the wall sections in place, to connect the bracing, to install individual components between wall sections and to install reinforcing bars. One workman is required to guide the panels at the bottom, to handle the bracing materials and to handle the individual components.



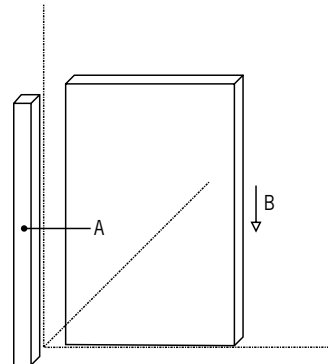
9.1a Erection of Pre-assembled Wall Section

3. The pre-assembled wall sections have unique locations and orientations that must be maintained in accordance with the CONFORM® layout drawings. Also, the top of each wall section must be identified in order for the coring to be aligned.

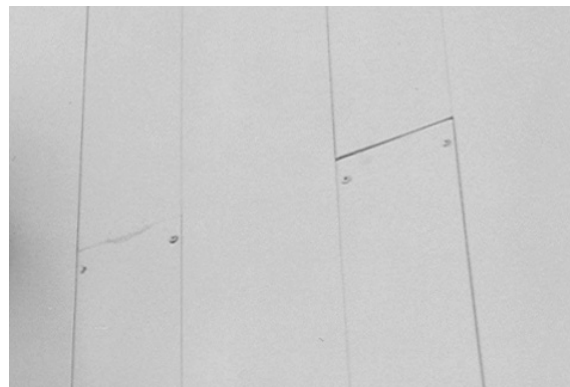
4. For low walls ( up to 20' ) Typically the pre-assembled wall sections have the connecting legs on one side and the grooves on the other end. The connecting component (typically a Universal component) is slid in between the pre-assembled sections.

5. The pre-assembled wall sections are inspected prior to lifting to ensure that all components are secured to each other and especially that the lower components below a staggered joint are adequately connected to the upper components that contain the hoisting bar.

6. The Corner component is placed on the foundation wall and held in place - see diagram 9.1b.

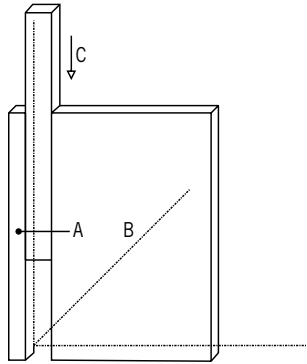


9.1b Erection of Pre-assembled Wall Section



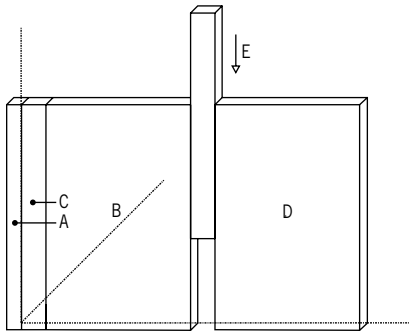
9.1c Screws at Staggered Joint

7. The first pre-assembled section is lifted into place– see diagram 9.1d.



9.1d Erection of Pre-assembled Wall Section

8. The joining component ( typically a Panel Component ) is slid in between the corner and first preassembled section. Subsequent preassembled sections are installed in the same manner – see diagram 9.1e.



9.1e Erection of Pre-assembled Wall Section

9. Prior to lifting, all dirt or ice is removed from the grooves of the panels at each side of a wall section and the grooves are lubricated, as necessary.

10. A 23.8 mm (15/16") diameter hoisting bar is placed in the second core from the top of the wall section. Chains and hooks are connected to the hoisting bar at approximately 375 mm (15") from each side of the wall section. If slings are used, a spreader bar is provided to prevent distortion at the top of the wall sections.

11. Two 7.5 m (25 ft) long ropes are connected to the bottom corners of the wall sections prior to lifting and are held by workmen at all times. The ropes are hooked through or tied to the coring at the second web from the sides the wall sections.

**12. Workmen never walk under a wall section lifted by a crane.**

13. A wall section is lifted adjacent to the dowels in the foundation. If the dowels will interfere with the webs of the components, the dowels are bent a minimum of 12 mm (1/2") away from the webs to allow for final adjustment of the wall section. The wall section is lifted away from the foundation prior to workers bending the dowels.

**14. Workmen shall never place their hands between a wall section and a dowel or between two wall sections. A sudden gust of wind will move the wall sections in an unexpected manner.**

15. The wall section is lifted above the dowels or the adjacent box connector and lowered into the correct position adjacent to the strapping or angle on the foundation.



9.1f Pre-assembled Wall Section Lowered over Dowels

16. The individual component or components are installed on the previous wall section before the next wall section is erected. The individual components are installed using a scissors lift or zoom-boom lift.

17. Bracing and sufficient temporary anchors are connected to each wall section prior to removing the slings and the hoisting bar.

18. As each wall section is erected, the bracing and anchors are completed as required to safely support the wall.

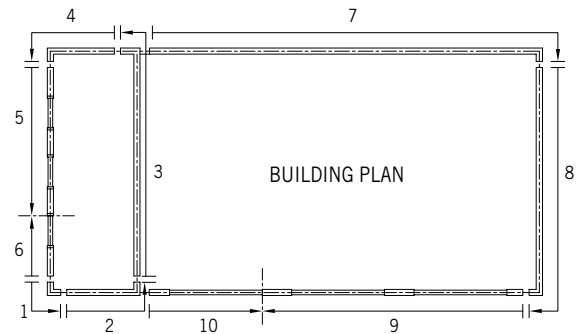
19. The exposed screws on the faces of the wall that were used to secure the components to each other at a staggered joint are removed once the bracing is completed. In special cases, it may be necessary to remove these screws to plumb the wall components, after the wall section is placed on the foundations.

## 9.2 INDIVIDUAL COMPONENTS

1. Individual components are provided to join wall sections together and construct short lengths of walls near corners and openings.
2. Typically, an individual box connector component is installed between wall sections. However, for a wall section with a finger joint, the lower part of the wall is joined with a box connector and the upper part of the wall is joined with a panel, a box connector and another panel.
3. Workmen on a scissors lift or zoom-boom lift install the connecting components. The components are lifted by a workman at the top and guided together by a workman at the bottom. Both workmen carefully slide the components down.
4. Also, refer to Section 8.

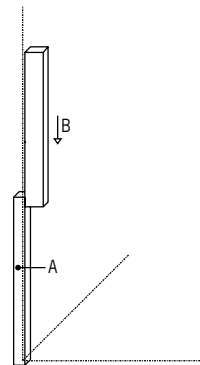
## 9.3 ERECTION PROCEDURE - HIGH WALLS

1. Start the erection of pre-assembled wall sections at one corner of a building and proceed around the building in a sequential manner. Typically, the erection is completed for sequential rectangular elements where interior walls divide the building into several areas or bays. The last wall section of each rectangle may be completed adjacent to an opening to assist in the placing of horizontal reinforcing steel.



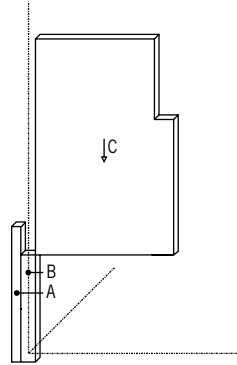
9.3a Erection Sequence for Wall Sections

2. Place the appropriate corner box into the corner – typically the longest corner component. Install the adjacent bottom component ( typically the shortest Panel component ) into the corner component – see diagram 9.3b



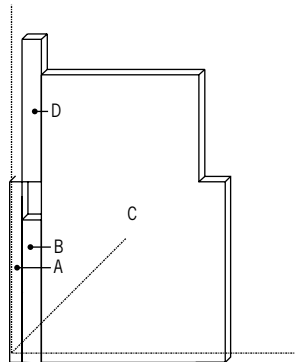
9.3b Erection Step 1

3. Lift one of the adjacent pre-assembled wall sections to 50mm (2") above the panel component and lower the wall until the section reaches the foundation- see diagram 9.3c.

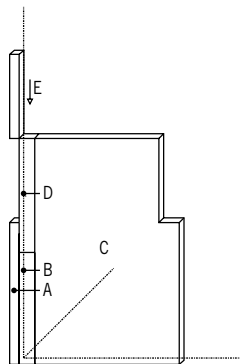


9.3c Erection Step 2

4. Install the top panel - - see diagram 9.3d. Install the top corner box - see diagram 9.3e.



9.3d Erection Step 3

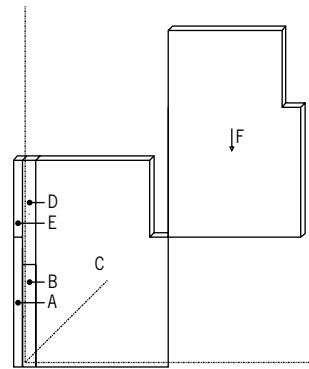


9.3e Erection Step 4

5. Accurately locate the wall section on the foundation, plumb both ways and connect the bracing.

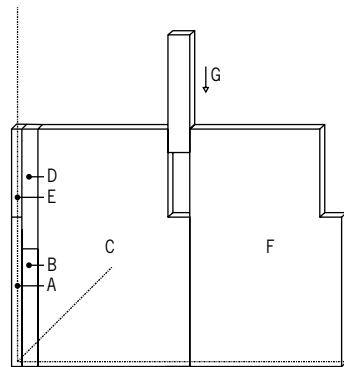
6. Before proceeding, install horizontal hooked corner bars if required. Refer to Section 11, Steel Reinforcing Placement.

7. Lift and install the next wall section into the grooves of the first pre-assembled section and lower to the foundation wall. - see diagram 9.1f.



9.3f Erection Step 5

8. Install top connecting component- see Diagram 9.3g. Continue installing pre-assembled sections adding top component as sections are installed.



9.3g Erection Step 6

9. Accurately locate the wall section on the foundation, plumb both ways and connect the bracing.



**10.** The wall sections are continued sequentially, in accordance with the CONFORM layout drawings, by repeating Items 6 to 10, including the wall sections for doors, windows and openings.

**11.** Temporary bracing and steel reinforcing bars are installed as the wall erection proceeds.

**12.** The wall erection is continually monitored to ensure the proper wall section sequence, component sequence and alignment of coring.

**13.** Measurements are taken along the length of the wall to ensure that the dimensions are maintained in accordance with the CONFORM drawings and that the wall sections are plumb in both directions. The wall sections are pulled or pushed together as the erection proceeds to ensure the specified dimensions and plumb are achieved.

**14.** Individual components are often used adjacent to corners, wall intersections, doors, windows and openings in order to achieve the specified dimensions. The spare components are substituted for some or all of the individual components where necessary to ensure that the specified dimensions are met. If required, some components are removed from the side of a pre-assembled wall section and spare components installed to suit the specified dimensions.

## 9.4 DOORS, WINDOWS, OPENINGS

**1.** Typically, the components for sills and headers at doors, windows and other openings are pre-assembled to suit the opening width.

**2.** The sill sections are erected consecutively with the full height wall sections. The header sections are erected after the full height wall sections are placed at each side of the opening.

**3.** Depending on the header height and length, the header sections are lifted using various methods. With the hoisting bar offset to one side, the wall section is placed on shoring, held by hand or held with a forklift while the hoisting bar is removed. Alternately, reinforcing steel bars less than the width of the wall section can be used as a hoisting bar and left in the wall.

**4.** Prior to removing the hoisting bar, a header section is supported on temporary formwork for the opening and is braced.

**5.** Openings may be required to be "site cut" to suit your requirements refer to section 7.6 for additional info.

# 10. PLACEMENT OF STEEL REINFORCING BARS

## 10.1 GENERAL

1. Reinforcing steel bars are provided as specified on the structural drawings for the project, provided by the project engineer.

2. Vertical bars are provided 25 mm (1") less than the height of the wall. The vertical bars are placed in the required component and spacing as required by the structural drawings. Wire hoops are tack welded or tie wired to the bars at 600 mm (2') from each end and at 3 m (10') maximum, with a minimum of two hoops per bar. The hoops are sized to suit the diagonal dimension of the component and are bent lightly as required. The hoops are located on the bars to suit the specified location of the bars within the width of the wall.



10.1a Vertical Reinforcing Bars

3. Typically, the vertical bars are erected as the wall erection proceeds and must be installed prior to the horizontal bars, except at corners.

4. If specified, the vertical bars are tied to the foundation dowels by lifting the individual component approximately 12". This must be done prior to placing the horizontal bars.

5. In some cases, the vertical bars are tied to the foundation dowels prior to erecting the CONFORM® components. The individual components are lifted over the top of the vertical bars.

6. Horizontal bars are installed after the vertical bars and are placed through the coring in the CONFORM components. The recommended length for a horizontal bar is 5500 mm (18'). The horizontal bars are installed after each 4667 mm (16') length of wall is erected or after each second wall section erected. The horizontal bars are lapped with the previous bars, as specified on the structural drawings. The ends of the bars do not project beyond the web of the last component so that the next component can be slid into place.



10.1b Horizontal Reinforcing Bars

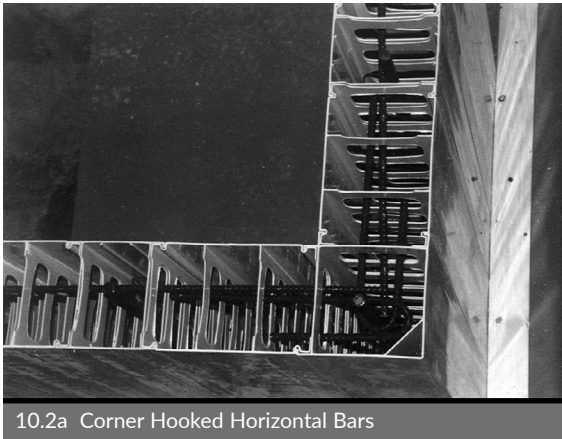
7. The horizontal bars are not tied in place. If required, the horizontal bars can be wedged between staggered vertical bars or wedged between vertical bars and the side of the coring.

8. At openings, vertical bars are placed at each side and horizontal bars extend a minimum of 610 mm (2') each side of the opening.

9. The horizontal bars are installed prior to erecting an end box or uncored starter at the end of the wall.

## 10.2 CORNER REINFORCING BARS

1. When corner horizontal bars are specified, 180° hooked bars are provided in each direction and are lapped with the straight horizontal bars. The 180° hooks are fabricated to suit the width of the CONFORM coring by using the same pin diameters as those for stirrups and ties. The overall length of the hooked horizontal bars is 600 mm to 900 mm (2' to 3'), as required to suit the specified lap length. The length of the hooked portion is 50 mm (2") longer than the width of the wall, so that the web will hold the hook horizontal.



2. The hooked horizontal bars are placed as soon as the wall erection extends beyond the end of the hooked bar. A vertical bar without hoops is placed inside the component and through the two overlapping hooked bars.



3. At the first corner, the hooked horizontal bars are installed from both directions. However, at the other corners, the hooked horizontal bars are installed into the wall prior to erection of the corner box. After the corner box is installed, the hooked horizontal bars are pulled back into the corner by reaching into the wall through the coring of the corner box. The wall is continued at the other side of the corner and the second hooked horizontal bar is installed as soon as the wall erection is beyond the end of the hooked horizontal bar. The hooked horizontal bars at intersections are installed in a similar manner.

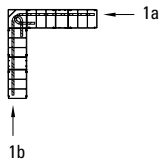
4. For walls with exterior cladding, the hooked horizontal bars in the final corner can be installed by cutting holes in the outer faces of the corner box connector and providing temporary formwork over the holes during concrete placement.

5. For walls without exterior cladding, the wall is designed with a control joint installed in a straight section of wall. The wall is erected each side of the control joint and the horizontal bars are installed at each side of the control joint before the final component is installed.

6. Alternately, for walls without exterior cladding, the horizontal bars are installed on each side of an opening and the bars at the header are pushed to one side of a final component. By reaching down into the header after the component is installed, the horizontal bars in the header are moved back across the component and lapped with the bars in the wall.

### 10.3 PLACEMENT SEQUENCE

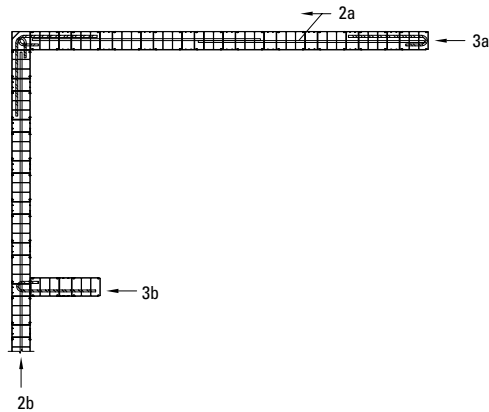
1. At the first corner, the hooked horizontal bars are installed from both directions.



10.3a First Corner

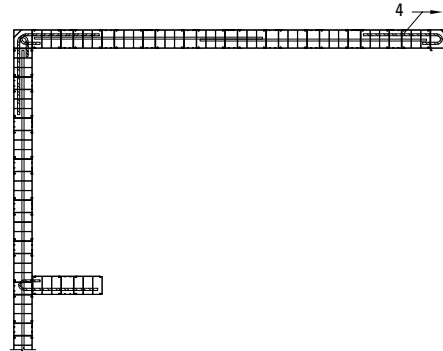
2. Straight horizontal bars are installed in straight walls adjacent to the first corner.

3. Horizontal hooked bars are installed at the ends of straight walls prior to installing the next corner and are installed at intersections after erecting a sufficient length of wall.



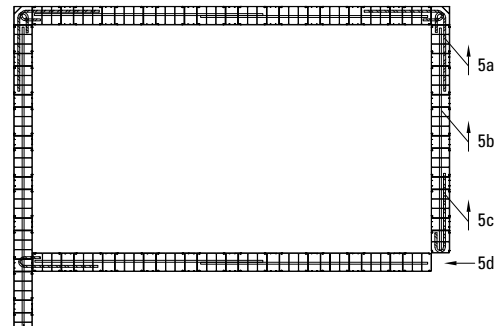
10.3b Straight Walls

4. After installing another corner, the horizontal hooked bars are pulled into the corner by reaching through the coring.



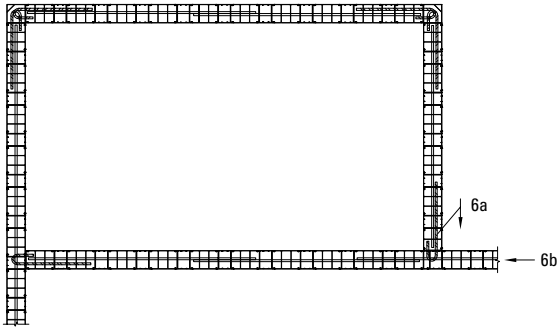
10.3c Other Corners

5. Horizontal hooked bars are installed in the other direction at a corner as soon as a sufficient length of wall is installed. Then straight bars are installed as the walls are continued from a corner or from an intersection.



10.3d Corner Walls and Intersecting Walls

6. Horizontal hooked bars and straight bars are continued around the project in a similar manner.



10.3e Continuation Around Project

7. If the exterior face is clad, the horizontal bars can be installed from the exterior by drilling holes in the exterior face at the corners and intersections.

8. If the exterior face is to be exposed, the last CONFORM component should be installed where a control joint is allowed and the horizontal reinforcing can be discontinuous. Alternately, the last CONFORM components could be installed above an opening where it is possible to reach into the components and move the horizontal bars to suit the specified lap.

# 11. BRACING

## 11.1 GENERAL

1. CONFORM® requires temporary bracing for lateral stability. The temporary bracing must withstand wind, seismic and other construction loads that may occur during erection of the components, during placement of the concrete and until installation of the permanent floor and roof members that provide a lateral load resisting diaphragm.
2. The bracing requirements for CONFORM are determined based on the wall thickness, the wall height, the wall layout, the presence of permanent or temporary framing (girts, columns, roof, etc.) and the wall erection method, which is either by individual components or by pre-assembled wall sections.
3. Also, the wall bracing scheme and technique depend on the specific site climatic conditions, soil and foundation conditions, material availability and local practices.
4. It is highly recommended that a local engineer or contractor be contacted to perform the bracing calculations and drawings. Refer to the Engineering Guide ([https://www.nuformdirect.com/wp-content/uploads/Engineering\\_Guide\\_v2.0.pdf](https://www.nuformdirect.com/wp-content/uploads/Engineering_Guide_v2.0.pdf)).
5. The wind and earthquake loads are calculated based on the applicable Building Code with the appropriate reduction factor for temporary bracing.
6. The CONFORM components provide permanent formwork for both faces of a wall and include integral cross-ties to hold the two faces together during concrete placement.
7. Under normal site conditions, the empty CONFORM components are able to span vertically between lateral bracing approximately 30 times the CONFORM thickness.

8. The temporary bracing is required to hold the wall straight and plumb, to provide the lateral stability for wind and seismic loads and to resist construction loads during placement of concrete.
9. Also, bracing is required for areas that are subject to unbalanced hydrostatic pressure during concrete placement. Typically, these areas include openings, corners, T-intersections and ends.
10. Unbalanced, hydrostatic pressures from the placement of concrete are calculated based on the appropriate standard for formwork design. The webs of the CONFORM components provide cross ties to hold the faces of the wall together, but the webs also restrict the flow of concrete in the plane of the wall and this force must be resisted by bracing.
11. **The bracing should be re-checked immediately prior to the placement of concrete to ensure that all members are properly installed and that the CONFORM components are correctly located, aligned and plumbed.**

## 11.2 BASE OF WALL

1. A continuous horizontal member is required at one side or both sides of the CONFORM components to hold the members straight.



11.2a Bottom Bracing at One Side

2. The bottom bracing member may also act as formwork to cover any gaps at the underside of the wall due to irregularities in the surface of the top of the foundation or slab.



11.2b Bottom Bracing at Both Sides

3. The bottom bracing member is anchored to the CONFORM components and the foundation as required for the lateral wind forces and vertical forces from rakers.
4. For bottom bracing member at one side of the wall, it is connected to the wall at 400 mm (16") on center, maximum. For walls over 5000 mm (16'), the connection to the wall is at 200 mm (8") on center, maximum, to prevent the wall from buckling laterally as the concrete is placed.

The connection to midheight bracing is at 200 mm (8") on center, maximum. The spacing of fasteners depends on the bracing location and local wind conditions. Refer to Section 6 of the CONFORM Engineering Guide ([https://www.nuformdirect.com/wp-content/uploads/Engineering\\_Guide\\_v2.0.pdf](https://www.nuformdirect.com/wp-content/uploads/Engineering_Guide_v2.0.pdf)).

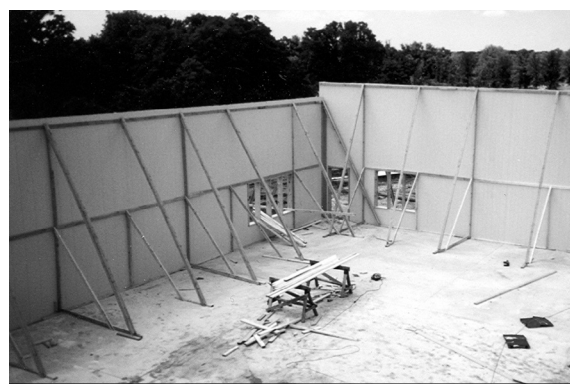
### 11.3 MID-HEIGHT OF WALL

1. For high walls, a continuous horizontal bracing member is required at one side or both sides to hold the wall straight at mid-height.



11.3a Mid Height Bracing at One Side

2. The bracing is connected to diagonal rakers that are anchored to deadmen or a slab, in order to hold the wall plumb.
3. The bracing is anchored to the wall and the rakers as required for lateral wind forces and vertical forces from rakers.



11.3b Mid Height Bracing at Both Sides

## 11.4 TOP OF WALL

1. A continuous horizontal bracing member is required at one side or both sides to hold the top of the wall straight.



11.4a Top Bracing at One Side

2. The top member may also act as formwork to provide a smooth level surface at the top of the wall due to minor variations in the lengths of the CONFORM components.



11.4b Top Bracing at Both Sides

3. The bracing is connected to diagonal rakers that are anchored to deadmen or a slab, in order to hold the wall plumb.

4. The bracing is anchored to the wall and the rakers as required for lateral wind forces and vertical forces from the rakers.

## 11.5 ENDS, CORNERS, INTERSECTIONS

1. The ends of walls, wall corners and wall intersections will tend to move laterally as the concrete is placed. In-plane bracing is required at the top and at intermediate locations to prevent wall elongation during concrete placement.



11.5a Bracing at End of Wall





11.5b Bracing at Corner



11.5c Bracing at Wall Intersection

2. In addition, the end, corner and intersection components require partial or full-height vertical formwork to maintain a flat surface and to prevent separation between the wall and starters or end caps.

3. For CF4 corners and CF8i exterior corners only, the full-height vertical formwork and intermediate bracing noted in Item 2 are not required for wall heights less than 3000 mm (10').

4. The formwork is pressed tight against the wall and anchored to the wall or the foundation. The formwork is braced at the top and at intermediate locations by diagonal rakers that are anchored to deadmen or a floor slab.

5. At the ends of walls, a steel channel can be added in the CONFORM component to reduce the concrete pressures on the formwork and help maintain a flat surface.

6. All wall intersections and piers, except for the CF4, are created using starters and these locations must be formed and braced full height to prevent the starter from separating at the intersection.

7. Box joiners in piers and near the ends of walls must be formed and braced full height to prevent the legs of the box connectors separating from the box joiner.



11.5d Bracing at CONFORM Pier



11.5e Bracing at High Pier

## 11.6 WALL OPENINGS

1. The components or wall sections are pre-fabricated to the dimensions of openings.
2. A continuous buck is required around all openings to resist the vertical and horizontal concrete pressure, to maintain a flat surface and to prevent the face of the opening from bowing.
3. The buck is formed using conventional wood framing.



11.6a Bracing at Opening

4. The buck is connected to the CONFORM components and to prevent separation between the wall and buck.



11.6b Bracing at Window Opening

5. All bucks require vertical and horizontal shoring at the header and jambs, respectively, to keep the opening square, to maintain the correct opening dimensions and to resist the concrete pressure and weight.



11.6c Bracing at Door Opening

6. The opening bracing is connected, when required, to diagonal rakers that are anchored to deadmen or a slab in order to hold the opening plumb and to prevent the wall from bowing at the opening.
7. The header and sill of openings more than 1.2m (4') wide require bracing on the face of the wall to maintain a flat plane across the opening.
8. Openings within 8' (2.5 m) of a corner or end of a wall shall have the opening and the corner or end tied together to maintain the dimension of the wall and to prevent bowing.

**9.** Openings for overhead doors are provided using a bent steel plate supplied with the structural steel. The bent steel plate is erected and temporarily braced to the structural steel. The wall components or sections at each side of the opening are pushed horizontally into the steel plate at each side and the header members are lifted and slide into the side components. All door headers shall be clamped to the bent steel plate frame at overhead doors to secure wall in place.



11.6d Bracing at Overhead Door

**10.** Small openings and sleeves for mechanical, plumbing services, and roof scuppers are site cut as required.

# 12. CONCRETE PLACEMENT

## 12.1 CONCRETE POUR

**1. Immediately prior to starting a concrete pour, the bracing must be re-checked to ensure that all members are properly installed and that the CONFORM® components are correctly located, aligned and plumbed.**

2. The ready-mix concrete is ordered in accordance with the specifications given in Section 3.2. The recommended concrete slump at the truck, is 150 mm (6") and typically, the concrete is placed using a boom pump. For small projects, the concrete may be placed with a trailer pump and hoses or with a small bucket suspended from a crane.

**3. Regardless of the method of placement, the concrete slump is tested for each truck prior to discharging the concrete. A slump less than 100 mm (4") at point of discharge is rejected since a stiff mix may result in significant honeycombing or voids. A high slump is required to ensure a monolithic concrete wall and to provide adequate pressure to seal the joints between the CONFORM components.**

4. The concrete placement crew is composed of 5 workmen and a foreman. One workman holds and moves the concrete pump hose. One workman trowels the top of the wall. One workman power washes the CONFORM surface and one person on each side of the wall visually checks and monitors the bracing and face of the CONFORM during the pour. In addition, truck drivers and concrete pump operator are required. Also, it is recommended that a NUFORM® field representative be on site during initial projects.



12.1a Concrete Pour in Progress

5. The hose of the concrete pump is provided with a reducer to 76 mm or 100 mm (3" or 4") maximum at discharge and an S bend at the end. A quick shut-off valve at the point of discharge is recommended. An elephant trunk is used to restrict the free-fall pressure if an S bend is not available. Concrete must not be discharged directly into the CONFORM components from a large vertical height.

6. An aluminum or wood concrete funnel is recommended to minimize spillage on the face of the CONFORM.



12.1b Concrete Funnel, Reducer and S-Bend

7. Direct visual contact is required between the concrete placers and the pump operator to control the flow and placement of concrete.

**8. Typically, mechanical vibration of the concrete is not required. If voids are suspected, a rubber mallet is used to tap the face of the CONFORM or external mechanical vibration is provided.**

9. Internal mechanical vibration is not recommended since it will increase the hydrostatic pressures and cause deformation of the faces of the CONFORM.

10. There must be no ice or snow within the components when placing concrete into the walls. Any ice or snow is removed by using hot water immediately prior to placing the concrete.

11. The placement of concrete will cause the CONFORM components to move laterally if large variations in concrete height are created. Small lifts of 5' to 6' (1.5 m to 1.8 m) at one time are used until the concrete achieves initial set.

12. The rate of concrete placement varies with the wall height, concrete mix and site conditions. Under ideal conditions pour rates as high as 5000 mm (16') per minute are possible for CF8i forms. For CF6 and CF8 walls, the pump is operated at a slow speed. A rate of 9 cubic meters (11 cu yds) per hour is recommended to reduce the surface bowing and lateral movement of the components.

13. Concrete is placed using the pump at its slowest speed or in a stop/start mode at all piers, corners, intersections and ends of walls.

14. Prior to filling the lower half of the wall in a uniform manner, the following areas are completed in sequence to hold in place or "lock-in" the CONFORM components. The pump is used at its slowest speed or in a stop/start mode and the concrete is allowed to achieve an initial set before continuing.

1. At window sills pour full height, up to 3 m (10') maximum
2. At headers over large openings pour full height up to 3 m (10') maximum
3. At each side of door jambs pour 1/2 wall height, up to 3 m (10') maximum

4. At corners and intersections pour 1/2 wall height, up to 3 m (10') maximum
5. For long walls pour a 1200 mm (4') long section, 3 m (10') high every 15 m (50') along the wall

15. Prior, to filling the upper half of the wall in a uniform manner, the following areas are poured in sequence. The pump is used at its slowest speed or in a stop/start mode and the concrete is allowed to achieve an initial set before continuing.

1. At headers over large openings pour full height
2. At each side of door jambs pour up to header
3. At corners, ends and intersections pour up to 3/4 wall height

16. Continuous visual inspection of bracing for vertical alignment and plumb is required at both the inside and outside of the walls during any concrete placement. The pour is stopped at any areas of CONFORM that start to move and continued only after the concrete has an initial set.

17. Continuous visual inspection is required to check for excessive bowing of the surface and blowouts at both the inside and outside of the CONFORM. The concrete pour is stopped or the rate of pour is reduced when problems are detected. As noted in Section 12.4, wood formwork and bracing is ready to provide temporary support for any problem areas that develop.

18. The concrete is poured within 25 mm (1") of the top of the wall and external vibration is used to ensure that the formwork is filled solid. The CONFORM faces are tapped with rubber mallets or an external mechanical vibrator is used, such as a quick cut saw with the guard down. Care should be taken to not damage the finished surface of the CONFORM.

19. After all concrete is settled, the formwork is filled to the top and the top of the concrete is screeded level with the top of the components. A wood float finish is provided.

## 12.2 INSERTS

1. Plastic fixing blocks are installed for wall caps while the concrete is wet.
2. Cast-in-anchors are installed in the top of the wall, as required.

## 12.3 WASHING

1. **The CONFORM surfaces are washed immediately after placement of concrete and before the concrete or the cement paste can harden or dry.** The concrete slurry is not left on the surface for more than 30 minutes after concrete placement since once hardened it is very time consuming to remove and the CONFORM finish may be damaged during the removal.
2. Both faces of CONFORM are cleaned using a power washer during the concrete pour as the slurry bleeds from the joints between the CONFORM components or as concrete is spilled on the faces of the walls.
3. Areas that are difficult to clean and small areas are cleaned using a water hose and broom.
4. A visual inspection of the CONFORM is done as the washing proceeds and any problems are corrected or noted for repair at a later date.

## 12.4 REMEDIAL MEASURES

1. Additional formwork is not required to hold the faces of the CONFORM flat except at specific locations as noted in Section 11. However, broken webs, concrete with excessive slump or mechanical vibration can result in hydrostatic pressures that may cause bulging or a blowout of the CONFORM face.
2. If a blowout occurs during placement of the concrete, the concrete pump and the concrete placement in that area is stopped immediately.
3. Blowouts usually occur during the first lift and usually if the concrete is poured too fast or too high. The workmen on each side of the CONFORM must always be checking during the pour for such occurrences.
4. Plywood forms and bracing must be on site and ready for use prior to starting the concrete pour.
5. At blowouts, the concrete is trowelled or power-washed out of the formwork so that a plywood form can be used to push the CONFORM face flat. Adequate bracing is provided to hold the plywood form in place before restarting the concrete pour.

## 12.5 BRACING

1. **The temporary bracing for lateral stability is removed only after the floor or roof structures are completed and provide the permanent lateral bracing.**
2. The vertical bracing and formwork at corners, intersections, ends, columns and pilasters are removed after the concrete has set, 4 hours minimum.
3. The bracing and formwork for openings is removed after adequate strength is reached, 72 hours minimum. Re-shores are provided when required.

# 13. FINISHING

## 13.1 CLEAN-UP

1. The faces of CONFORM® are wiped with a damp clean cloth to remove any surface dirt. An approved cleaner is used to remove any difficult to remove marks or stains.
2. The surface may be given a final wash with a degreaser to provide a glossy appearance.
3. The spare or extra components are discarded or cleaned and stored off-site for future projects.
4. All debris is removed from the work area.

## 13.2 MULTI-STOREY BAND

1. A multi-storey band is installed to cover any joints, to cover holes from mid-height bracing or as an architectural feature. The band is installed in lengths of approximately 2 m to 3 m (6' to 10') long with a 25 mm (1") gap between the pieces.
2. The band is fastened to the wall face with #6 x 5/8" stainless steel screws in slotted holes at 400 mm (16") on center maximum.
3. A multi-storey band channel cap is snapped into the center of the band to cover the screws.
4. A multi-storey band joint cover, 200 mm (8") long, is snapped over the band to cover the joints.
5. A multi-storey band joint cover, 400 mm (16") long, is scored with a knife, heated with a heat gun and bent around the corners to cover the corner joints.

## 13.3 CAULKING

1. When the base of the wall is below the finish floor, caulking may be applied at the base of the wall, around the exterior perimeter, between the underside of the wall insulation and the top of the foundation wall. The caulking must not prevent the joints between the box connectors and panels from draining to the exterior.

2. When the base of the wall is flush with the interior finished floor, caulking is applied at the base of the wall, around the interior perimeter, from the wall face to the floor slab. Caulking must not be applied on the exterior side of the wall.

3. Caulking is applied between the exterior face of the wall and the bent steel plate at the jambs around the overhead doors. Caulking must not be applied at the exterior face of the header flashing and frame.

4. Caulking with backing rod is applied at expansion joints and at all control joints between CONFORM and other walls.

5. Silicone sealant can be applied to CONFORM. Caulking shall be a one part, neutral cure, oxime, silicone sealant. The following silicone sealants have proven effective for use on CONFORM:

1. Dow Corning Dowsil™
2. Tremsil® 600
3. Bondaflex® Sil 200GPN

<https://www.dow.com/en-us/pdp.dowsil-1199-silicone-glazing-sealant.04031863z.html#tech-content>

[https://www.tremcosealants.com/fileshare/DataSheets\\_Hyland/Tremsil\\_600\\_DS.pdf#page=1&zoom=auto,-259,798](https://www.tremcosealants.com/fileshare/DataSheets_Hyland/Tremsil_600_DS.pdf#page=1&zoom=auto,-259,798)

<http://www.masco.net/pdf/catalogs/liquidandpowder/datasheets/bondaflex/sil200gpn.pdf>

6. Prior to use, CONFORM should be clean, and free from dirt and debris. Apply as per manufacturers' recommended instructions.

### 13.4 MAINTENANCE

1. Routine cleaning of CONFORM is the best deterrent to long term build up of dirt, stains and other contaminants. Normal maintenance consists of washing with REVIVE or mild soap and water using a soft cloth or ordinary long-handled soft bristle brush. The recommended cleaner REVIVE is a non-toxic cleaner available from NUFORM.

2. Stains that are difficult to remove may require special treatment. Most non-abrasive cleaners can be used on CONFORM, although some are easier to use. Preferably, use a cleaner that will not leave a film on the surface or dull the finish over time.

3. Stain removal is affected by factors such as area involved, severity of stain, application or use (e.g. car wash buildings), and duration of exposure, regional factors

(e.g. harshness of water), and atmospheric conditions. The recommended cleaners outlined in Table 13.1, were found to be adequate, but shall not be taken as a warrant or guarantee.

4. The method of removal of a specific stain should be determined by testing a small sample area first. For further assistance contact NUFORM or your NUFORM representative.

5. The following cleaners are not recommended for use on CONFORM as the chemical composition of these cleaners may harm the face or the finish of CONFORM over time.


- Chlorox
- Pine Power
- Grease Relief
- Tide Power (laundry detergent)
- Ivory Liquid Soap
- Nail Polish Remover



13.4 Finished Project with CONFORM



**TABLE 13.1: WALL CLEANING CHART**

Recommended Cleaners	Stains															Comments			
	Common Dirt	Grease & Oil	General Stains	Pencil Marks	Permanent Marker	Paint	Scuff Marks	Pen/Ink	Lipstick	Bubble Gum	Crayon	Grass Stains	Rust	Mold & Mildew	Tar	Dulls Finish	Toxic – Handle With Care	Easy to Use	2 Steps or More
	✓	✓	✓	⊘	⊘	⊘	⊘	⊘	⊘	⊘	⊘	⊘	⊘	⊘					
Nuform Graffiti Remover	✓	✓	✓	✓	⊘	✓	✓	✓	✓	✓	✓	✓	✓	✓	⊘	✓	✓	✓	
Castrol – Super Clean Degreaser	✓	✓	✓	✓	⊘	⊘	⊘	✓	✓	✓	✓	✓	✓	✓	⊘				
Armstrong – New Beginning Wax Remover	✓	✓	✓	✓	⊘	⊘	⊘	⊘	✓	✓	✓	⊘	⊘	⊘				✓	
Windex – Outdoor Cleaner	✓	✓	✓	✓	⊘	⊘	⊘	✓	✓	✓	✓	✓	✓	✓	⊘			✓	
Armour All – Multi-Purpose Cleaner	✓	✓	✓	✓	⊘	⊘	⊘	⊘	✓	✓	✓	✓	⊘	✓	⊘			✓	
Mastercraft Paint & Varnish Remover	✓	✓	✓	✓	⊘	✓	✓	⊘	✓	⊘	⊘	⊘	⊘	⊘		✓	✓	✓	
Mastercraft Graffiti Remover	⊘	⊘	✓	✓	⊘	⊘	⊘	⊘	⊘	⊘	⊘	⊘	⊘	⊘		✓	✓		
Muratic Acid Solution	✓	✓	✓	⊘	⊘	⊘	⊘	⊘	✓	⊘	✓	✓	⊘	✓	⊘	✓	✓	✓	
Fantastic	✓	✓	✓	⊘	⊘	⊘	✓	✓	✓	✓	⊘	✓	✓	✓	⊘			✓	
Murphy's Oil	✓	✓	⊘	⊘	⊘	⊘	⊘	⊘	✓	✓	⊘	✓	✓	⊘	⊘				
Lestoil	✓	✓	⊘	⊘	⊘	⊘	⊘	⊘	⊘	⊘	✓	⊘	⊘	⊘					
Windex	⊘	✓	⊘	⊘	⊘	⊘	⊘	⊘	⊘	✓	⊘	✓	✓	✓	⊘				
Water Base Cleaners	⊘	⊘	⊘	⊘	✓	⊘	⊘	⊘	⊘	⊘	⊘	⊘	⊘	⊘					
Vinegar & Water	✓	⊘	⊘	⊘	⊘	⊘	⊘	⊘	✓	⊘	⊘	⊘	⊘	✓	⊘				
Soft Scrub	⊘	✓	⊘	✓	⊘	✓	⊘	⊘	⊘	⊘	⊘	⊘	⊘	✓					

✓ - Recommended

⊘ - Not Recommended

# 14. CONFORM® REPAIR

## 14.1 PATCHING

1. Like any wall surface product, CONFORM® is not immune to neglect or damage. There are two types of damage than can affect the wall: structural or non-structural surface damage.
2. Damage of a structural nature (i.e. the concrete wall has been severely damaged and may cause the wall to fail), must be reviewed by a structural engineer. The concrete wall will need to be repaired to ensure it is structurally sound before the surface is repaired.
3. Small non-structural surface damage, during construction or after, can be patched with a Bondo Patch Kit and are painted to match the wall color. Refer to this section Construction Bulletin #19 (<https://www.nuformdirect.com/wp-content/uploads/Construction-Bulletin-19-CF8i-Exterior-Face-Repair.pdf>).
4. Large non-structural surface damage, such as large holes or blowouts, are patched by cutting out the face of a wall, chipping and restoring the concrete and installing a new facing. The new facing is cut from spare components and secured to the concrete with a polyurethane construction adhesive such as LePage Bulldog Grip 'PL' Premium™. The Bondo Patch Kit is used to patch at the edges of the new facing, as required.
5. Any large areas of surface damage to the insulated face of the CF8i components, after the wall is poured, can be repaired by removing and replacing the insulated cells of the components. A NUFORM® representative should be contacted for further information of the remedial measures.

## 14.2 MATERIALS AND TOOLS REQUIRED

### Materials:

- All Purpose Putty by Bondo Corporation
- Fiberglass Cloth for Automotive and Marine Repairs
- Kolorbond Spray Paint by Formula 40 USA Inc.

### Tools:

- Utility knife
- 2" or 3" putty knife or plastic spreader
- Masking tape
- Medium Aluminum Oxide sandpaper 80 to 100 grit
- Fine wet/dry Aluminum Oxide sandpaper, 200 to 320 grit
- Fine wet/dry Aluminum Oxide sandpaper, 1000 to 1500 grit
- Fine wet/dry Aluminum Oxide sandpaper, 1500 to 2000 grit
- Tack cloth
- Electric buffer with very mild abrasive paste or wax
- Light duty grinder for medium sandpaper (optional)

### 14.3 REPAIRING SURFACE DAMAGE - PATCHING HOLES NON-INSULATED FACE

For non-structural damage (i.e. surface damage), the wall can be repaired using the following procedures (see figure 14.1):

**Step 1 – Cut a rectangle hole** in the polymer around the damaged area. A neat square or rectangular patch is easiest to cut with the wall filled with concrete and easiest to patch. Inspect for cracks and loose material. Clean concrete and wall to ensure surface is free of any loose material, dust, oil, grease etc. Chip concrete flush to inside face of polymer, if required.

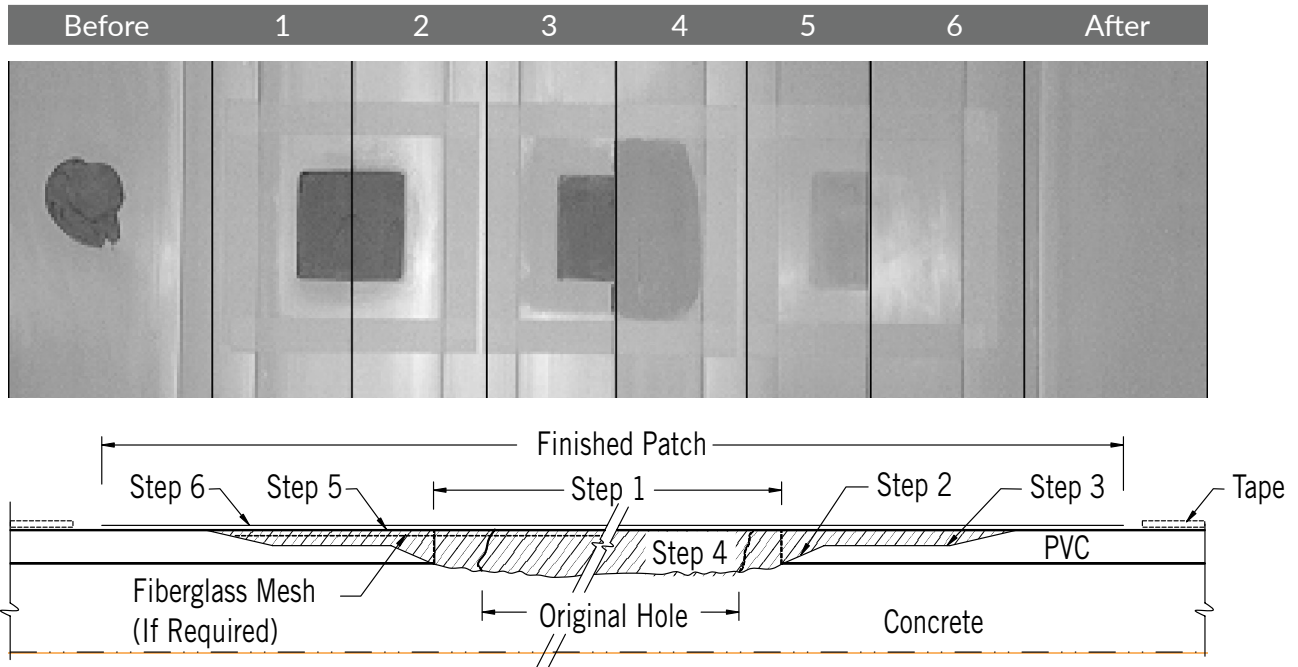
**Step 2 – Bevel cut the edge** of the polymer all around the hole at 45° angle or flatter to provide good bond for patching compound. Before sanding, protect the adjacent wall finish from damage by applying masking tape at 40 to 50 mm beyond the opening at the top and bottom and at the closest joint between components on the sides of the opening.

**Step 3 – Sand around the hole** with medium aluminum oxide sandpaper (80 to

100 grit). Vigorous sanding must create a small depression with a rough surface, 0.5 mm deep and 10 to 15 mm beyond the hole. This will improve the bond for the patching compound, allow a flush finish for the patch and reduce the possibility of future cracks. Ensure that the sanded area and hole are dry and clean.

**Step 4 – Apply the patching compound**, a two-part polyester resin all-purpose putty, to the hole and the sanded depression. Mix the compound and the cream hardener thoroughly, following the instructions on the label. Apply the compound with a 2" or 3" putty knife or a plastic spreader, depending on the size of the patch. Also, the compound may have to be applied in 2 or 3 layers depending on the size of the patch. For large patches, apply a layer of fiberglass cloth between layers and extend 10 to 15 mm beyond the hole. Apply the compound to leave a smooth, flat surface that is raised very slightly above the surrounding surface. A good quality trowel finish can significantly reduce the sanding required to obtain an acceptable patch.

**FIGURE 14.1: REPAIRING SURFACE DAMAGE - Patching Holes**



**Step 5 – Sand the patching compound** after it is dry. Follow the instructions on the label. It usually requires a drying time of 10 to 15 minutes in good conditions before sanding. First, use aluminum oxide medium sandpaper (80 to 100 grit) to eliminate all excess material and to featheredge the patch to the desired shape and surface. Allow the compound to dry an additional 10 to 15 minutes and then sand with fine wet or dry sandpaper (200 to 320 grit). Finally, sand with fine wet sandpaper (200 to 320 grit), that is moistened, and create a finish surface as smooth as the original polymer. Ensure that the entire surface is dry and free of all dust prior to painting. Prior to painting, repair and extend the masking around the area to be painted, as required.

**Step 6 – Paint the patched area** with a color-matched paint that is formulated for permanent use on PVC and other rigid thermoplastics. Apply the paint to avoid over-spray and apply in light layers to avoid runs and dripping. Allow first coat to dry before applying a second coat. Between coats, lightly sand the area with fine wet sandpaper (1000 or 1500 grit), which is moistened. After the final coat, remove the masking and lightly sand the area again with fine wet sandpaper (1500 or 2000 grit), that is moistened. The final sanding is to blend the edge of the paint to the existing polymer and the sanding must be parallel to the joints (parallel to length of the components). Finally, buff the painted area with an electric buffer and a very mild abrasive paste or wax (vinyl floor wax or polishing compound).

**14.4 REPAIRING SURFACE DAMAGE - PATCHING CRACKS OR BUTT JOINTS**

1. Clean the cracks and remove any loose material. Clean area as much as possible and ensure surface is free of any loose material, dust, oil, grease, etc.

2. Bevel cut the edge of the polymer along both sides of the crack. Before sanding, protect the adjacent wall finish from damage by applying masking tape at 40 to 50 mm beyond the crack at the top and bottom and at the closest joint between components on the sides of the crack.

3. Follow steps 3 to 6.

**14.5 CF8I EXTERIOR FACE REPAIR**

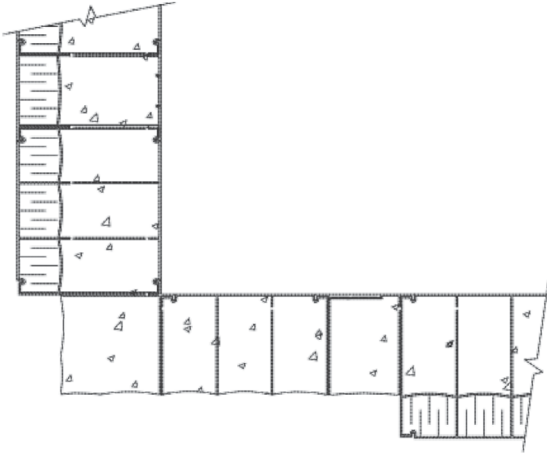
The Repair of the CF8i Exterior Face involves removing and replacing the insulated cells of the CF8i components. This method of repair is used where the size of the damaged area is too large to be patched with an All Purpose Putty. This repair method will take 2 men, approximately 2 days, to replace a 1100 mm (43") wide section of wall.

1. Exterior Insulated Face Removal
  - The multi-storey band or top flashing is removed as necessary.
  - Sawcuts 50 mm (2") deep are made along the edges of the damaged components using a circular saw. Vertical cuts occur in box connectors and are 25 mm (1") from joints.
  - Additional vertical cuts and horizontal cuts at 1.2 m (4') on centre are made to aid in removal of the damaged portion.
  - The exterior insulated face is removed carefully ensuring that adjacent components are not damaged.



**FIGURE 1 - DAMAGED WALL**

2. Exterior Surface Preparation
  - Using chisels, claw hammers, scrapers, grinders and saws, the remaining PVC skin is removed to reveal the bare concrete.
  - The PVC webs are cut and ground flush with the face of the concrete.
  - The edge of the panel at each side of the repair is exposed and cleaned flush to the face of the concrete.



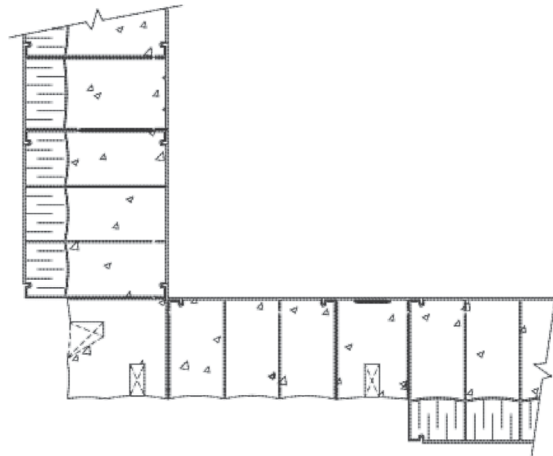
**FIGURE 2 - SURFACE PREPARATION**

3. Material Preparation
  - The replacement corner boxes and straight box connectors are ordered with 14 ga steel plates placed full height in the insulation cavities prior to foaming.
  - The replacement facing components are ordered with the insulation cavity detached from webs of the components.
  - Self-Drilling Hex Head Screws, 1/4" dia x 2" long, are installed on the back of the replacement box connector facing components. The screws are installed in the centre of the steel plates so that the head of the screw projects 38 mm (1 1/2"). The screws are located 100 mm (4") from the top and bottom and 610 mm (24") on center, maximum.



**FIGURE 3 - REPLACING FACING COMPONENTS**

4. Material Preparation
  - Holes are drilled 3/4" dia x 2" deep into the concrete to match the location of the screws in the replacement box connector components.
  - At one side of corners, the drilled holes are chipped horizontally to create a bevelled slot in order to install the corner section.
  - ALL COMPONENTS ARE DRY FIT TO ENSURE A SMOOTH FINISHED SURFACE. The face of the concrete especially at corners and at each side of the repair is ground to ensure a good fit for the new facing.

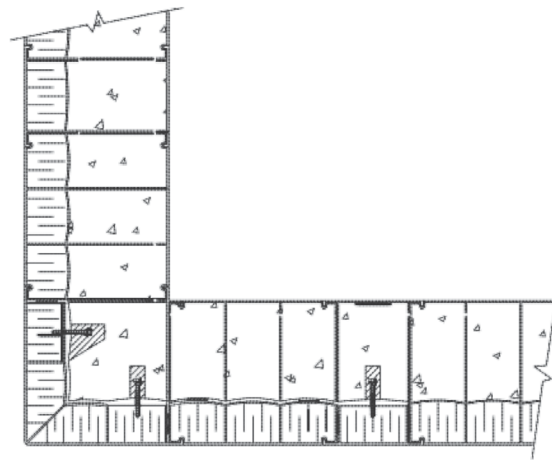


**FIGURE 4 - DRILLED HOLES**

## 5. Exterior Facing Installation

- Lepage Bulldog Grip "PL" Premium Polyurethane Construction Adhesive is applied to the concrete at the panel locations. The adhesive is applied at both sides of the replacement panel facings, in 50 mm (2") dia. blobs, 3/4" thick, and is located 100 mm (4") from the top and bottom and 610 mm (24") on center. The panel section is put in place and pushed hard to ensure a good bond.
- A 10 mm (3/8") bead of the Bulldog Grip Adhesive, 300 mm (12") long is applied along each side of each panel section, centred on each of the drilled holes for the box connector facings.
- Starting at a corner, the holes for the screws are filled with Simpson Strong Tie "AT" Acrylic Based Anchoring Adhesive (Model AT30). This product has a short curing time and the work must be done rapidly to ensure a good fit before the adhesive sets.
- Immediately after applying the adhesive, the corner replacement facing is pushed into place and interlocked with the adjacent undamaged panel at one side and the adjacent replacement panel facing at the other side. The corner box is held with braces at 1.5 m (5') on centre for 5 to 10 minutes until the adhesive sets.
- The other box connector facings are installed in a similar manner. Each piece is installed immediately after the epoxy adhesive is placed in the holes for the screws and the piece is held in place with bracing for 5 to 10 minutes. If required, the adjacent replacement panel facing can be pushed sideways slightly to suit the box connector facing legs, while maintaining the adhesive bond to the concrete.

- To complete the installation, the multi-storey band or top flashing is replaced.



**FIGURE 5 - REPLACEMENT FACING INSTALLED**

### Materials:

- Replacement CF8i insulated facing components
- Polyurethane Construction Adhesive and caulking gun - Bulldog Grip 'PL' Premium Polyurethane Construction Adhesive by Lepage
- Two Part Epoxy Adhesive and applicator gun - Simpson Strong Tie 'AT' Acrylic Based Anchoring Adhesive, Model AT30 by Simpson Strong Tie - include 10 to 15 spare applicator nozzles for each cartridge of adhesive
- 1/4" dia x 2" long Self-Drilling Hex Head Screws
- Bracing materials

### Tools:

- Circular Saw
- Claw Hammer
- Chisel
- Scraper
- Grinder with Concrete Blades
- Hammer Drill with 3/4" concrete bit
- Cordless Drill with hex head driver

# 15. ALTERNATE WALL FINISHES

## 15.1 CONFORM®

1. CONFORM® is a finished product and is available in two basic colors: Tan (color # 316) and White (color # 138). Although CONFORM derives many of its advantages when left in its finished state (e.g. low maintenance), it is versatile and accommodates most traditional wall finishes available on the market.

## 15.2 ACRYLIC STUCCO - GENERAL

1. Acrylic stucco applications have become very popular over the years and are ideally suited to be applied to the interior or exterior surfaces of CONFORM. Stucco is one of the most versatile cladding systems and offers the end user with almost unlimited finishing possibilities, textures and colors.

2. Stucco applications can be installed directly to CONFORM types CF4, CF6 and CF8 using an adhesive conditioner or on an insulation board. For CONFORM type CF8i, stucco must be applied on an insulation board using an EIFS system. Do not apply stucco directly over the insulated face of the CF8i components, since thermal movements will crack the stucco. The ideal stucco material for use with CONFORM is a premixed, water based acrylic coating.

3. Consult the manufacturer and installer to verify the suitability of the stucco, the required primer, the recommended application procedures and the limitations on use of their product. NUFORM assumes no liability for any finishes or for any damage to the CONFORM surface.

4. The following steps should be considered prior to any stucco application:  
Surface Preparation:

- CONFORM should be filled with concrete prior to stucco application

- The CONFORM surface should be clean and free from any debris, including spill over from concrete pour and lubricants if used in sliding panels. If the surface includes contaminants the stucco application may not bond properly
- Refer to manufacturers' guidelines for proper storage and transportation of stucco materials

5. Application of acrylic stucco systems should only be carried out using products that have been fully evaluated and deemed suitable by the manufacturer for use with CONFORM.

- Please contact your local stucco dealer or contact NUFORM for further info.

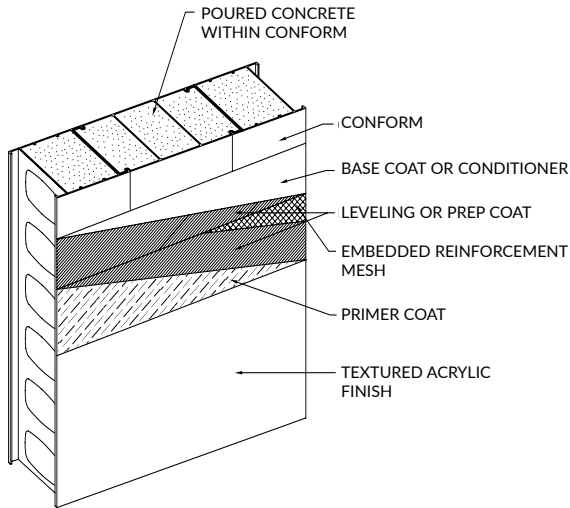
## 15.3 STUCCO - DIRECT APPLY METHOD

1. Most direct apply stucco applications consist of the following steps:

- Base coat or conditioner. This material is applied directly to CONFORM. This material basically prepares CONFORM to receive the stucco application and ensures proper bonding
- Leveling or prep coat is applied on top of the base coat or conditioner
- A reinforcing mesh is then applied to the leveling or prep coat
- Another application of the leveling or prep coat is applied to further encase the reinforcing mesh
- A primer coat is then applied
- Finally, a textured finished coat is applied

2. Refer to manufacturer for specific installation instructions.

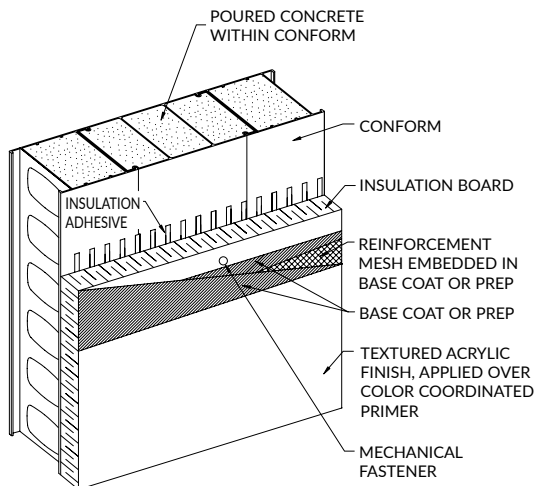
**FIGURE 15.1: STUCCO - DIRECT APPLY METHOD**



#### 15.4 STUCCO - EIFS SYSTEM METHOD

1. Insulation board must be properly fastened to the wall prior to installation of the stucco application. The insulation board can be mechanically fastened to the wall or glued to CONFORM using an approved adhesive.
2. Once the insulation board is applied to the wall, refer to manufacturers' guidelines for proper stucco application over the insulation.

**FIGURE 15.2: STUCCO - EIFS SYSTEM METHOD**



#### 15.5 VINYL GRAPHICS

1. Vinyl graphics are an ideal finishing material for a variety of reasons. Vinyl graphics are easy to find and reasonably priced, and offer the user a great deal of flexibility in design and color choices. Graphics can also be changed easily when required.
2. The following minimum specifications are required for use on CONFORM:
  - Vinyl graphic specified should be for indoor/outdoor use with UV ink or coating
  - Self adhesive backing
3. The installation procedure consists of the following steps:
  - CONFORM should be free of lubricants if used in sliding panels, dirt, grease, dust, etc.
  - Before removing backing from vinyl graphic, dry mount to ensure graphic fits properly on the wall. Once the graphic is positioned in place, mark to wall for future reference. Usually, graphics will come in rolls of 36" in width, so install rolls in sequence and make sure graphic subject borders align.
  - Start by removing a small section of backing paper, and apply graphic to wall. As you unroll and stick the graphic, remove trapped air with a spreader or spatula (rubber preferable), achieving a smooth surface. Continue this procedure until roll is finished.
  - Repeat until all rolls are applied.
  - Optional procedure – using a sharp blade or razor, cut the vinyl graphic vertically along the joints in the wall panels. Using a hard roller, smooth the vinyl graphic strips into the joints in the wall.



## 15.6 PAINT

1. Generally, paint can be applied to CONFORM only if it is recommended for use on PVC based products.
2. Consult the paint manufacturer to verify the suitability of the specific paint, the required primer, the recommended application procedures and limitations on use of their product.
3. Paint applied to the surface of CONFORM should be a light pastel color that will not create a heat build-up on the surface. Dark paints that absorb heat may cause deformation of the CONFORM material, especially the insulated CF8i forms.
4. Paint will not permanently cover or hide the joints between the CONFORM components and paints spanning over the joints may crack.
5. All paints should be tested on a sample area for weatherability and performance before application.
6. The following minimum recommended material and tools are required in order to properly paint CONFORM.

### Materials:

- Particle Mask or Dust Mist Respirator Mask
- Safety Goggles
- Masking Tape (various sizes)
- Blade
- Paint Roller Tray
- Drop Cloth (various sizes)

### Tools:

- Spray Gun, Air Atomized
- Paint Brush (various sizes)
- Paint Roller and Extension Handle

7. Always clean tools properly when finished, and always refer to manufacturers' guidelines for proper use and care of products and tools.

8. New surfaces must be clean and free from oil, grease, wax, and other foreign matter. Use a recommended primer as the first coat (white or gray color recommended based on color of CONFORM), and then finish with 2 coats of the final color. Thinning is normally not required, unless applying on air or surface temperatures above 80°F, in such case a retarder may be used to slow the drying process.
9. Previously painted surfaces must be clean and free from oil, grease, wax and other foreign matter. Remove any loose paint by water blasting, scraping or wirebrushing. Apply primer to any areas cleaned to bare PVC the same as described for new surfaces in section 15.6.8. Apply two finish coats for desired appearance.
10. Please contact your local supplier or NUFORM® for further information.

## 15.7 INSULATION AND SIDING

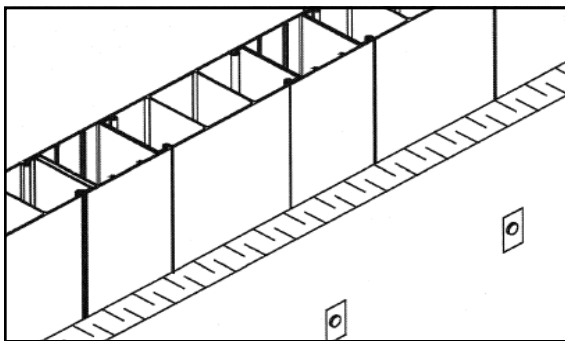
1. Among the numerous advantages of CONFORM over conventional building materials and methods is the superior energy efficiency rating utilizing the benefits of thermal mass of concrete. By using rigid board wall insulation (R5.0 per inch or RSI0.87 per 25 mm) on the exterior of CONFORM, all thermal bridging in the walls are effectively eliminated. For further information on the thermal performance of walls with CONFORM, please refer to the Technical Guide ([https://www.nuformdirect.com/wp-content/uploads/Technical\\_Guide\\_v2.0.pdf](https://www.nuformdirect.com/wp-content/uploads/Technical_Guide_v2.0.pdf)).

2. Insulation boards are mechanically fastened to the wall. For all options, the length of the fastener for securing the insulation should be a minimum 0.75" (19 mm) longer than the thickness of the insulation. Fasteners for insulation should have heads or washers that are .5" (12.7 mm) in diameter where cladding (i.e. vinyl siding) is installed directly against the insulation. Note that to achieve the desired thickness of insulation, two layers of insulation may be used and fastened to the wall in a similar manner as described herein. Around the perimeter of each insulation board and all openings, fasteners are placed 4" (100 mm) from the edge. Along the vertical edge of the board, fasteners should be no more than 6" (150 mm) apart and in grids no greater than 12" by 24" (300 mm by 600 mm) for the rest of the board.

### 3. Option 1 - Plastic Washer Method

The insulation is fastened with flathead screws and plastic flat washers. The siding is fastened to the wall using flathead screws (thickness of insulation + 1" (25 mm)).

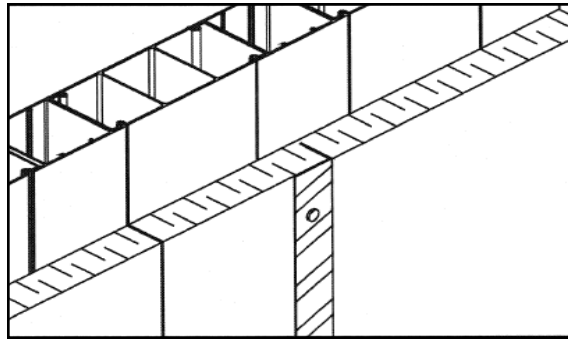
FIGURE 15.3: PLASTIC WASHER METHOD



### 4. Option 2 - L or Angle Method

The insulation is fastened with flathead screws and plastic flat washers. The L-shaped galvanized steel angle is fastened through the insulation to the wall (fastener length is thickness of insulation + 1" (25 mm)). The siding is fastened to angles using 1" (25 mm) Tek screws as per manufacturer's recommended spacing.

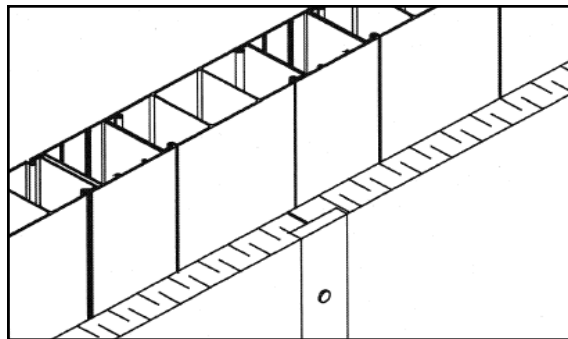
FIGURE 15.4: L OR ANGLE METHOD



### 5. Option 3 - Wood Furring Strip Method

Certain insulation brands allow for the installation of wood furring strips, which are fastened through the insulation to the wall (fastener length is thickness of insulation + 1" (25 mm)). The siding is fastened to the furring strips using 1" (25 mm) flathead screws as per manufacturer's recommended spacing.

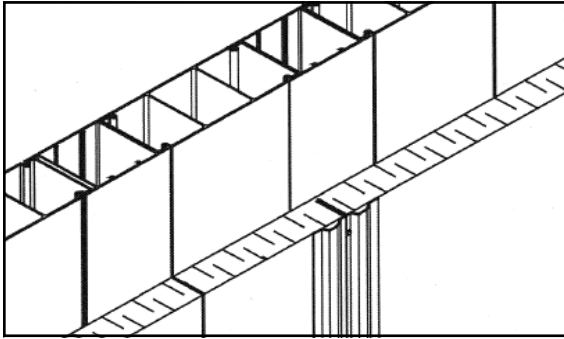
FIGURE 15.5: WOOD FURRING STRIP METHOD



### 6. Option 4 - T-Strip Method

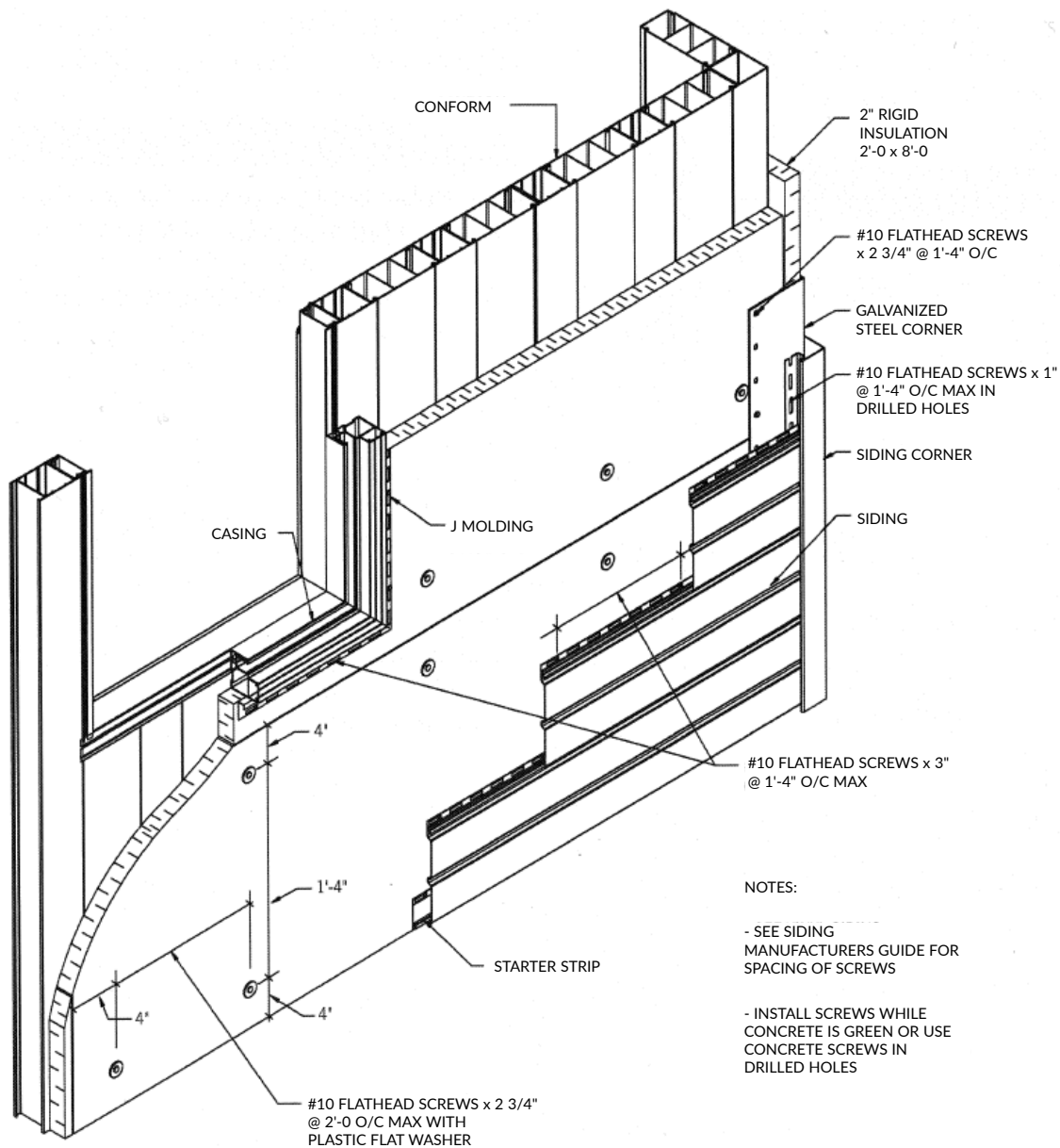
The insulation is fastened with flathead screws (thickness of insulation + 1" (25 mm)) and plastic flat washers. The galvanized steel T-strip angles are fastened through the insulation to the wall. The siding is fastened to the angles using 1" (25 mm) Tek screws as per manufacturer's recommended spacing.

**FIGURE 15.6: T-STRIP METHOD**



7. If siding is fastened to the walls using Option 1 (without furring strips), the length of the fastener used to secure siding through the insulation to the wall should be a minimum 0.75" (19 mm) longer than the combined thickness of the insulation and siding. For the remaining options, fasten the siding to furring strips or steel angles as per the recommendation of the siding manufacturer.

**FIGURE 15.7: INSULATION AND SIDING**



Above diagram illustrates Fastening Option 1: Plastic Flat Washer Method

## 15.8 GYPSUM BOARD

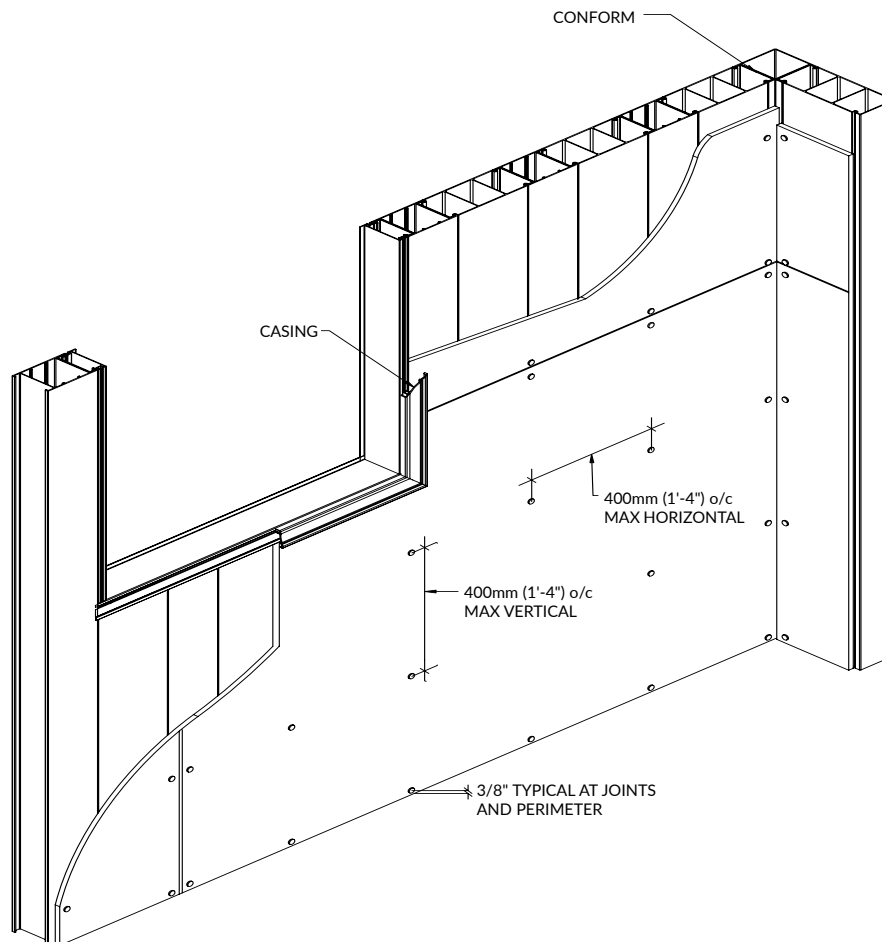
1. Gypsum board may be required over the interior face of CONFORM in order to meet a specific application, or if the user desires a flat smooth surface to apply a secondary finishing options such as paint or wall paper.
2. If gypsum board is installed for appearance only, and not required as a fire barrier, it may be applied using an approved PVC adhesive. The gypsum board can also be mechanically attached to the wall using screws and fastened at the joints between the panel and boxes; this allows for easier installation, as the screws need not go through to the concrete wall. The length of the screw should be adequate to penetrate

the thickness of the gypsum board and no more than 0.5" (12 mm) into the joint between the boxes and panels.

3. If gypsum board is installed using mechanical fasteners, it must be fastened directly into the concrete using appropriate concrete screws (#6 x 1 1/4" (30 mm) bugle head drywall screws recommended for 1/2" (13 mm) gypsum board). A minimum embedment depth of .75" (19 mm) is recommended.

4. To facilitate fastening into the concrete, gypsum board may be installed while concrete is still green. Fasteners should be located a minimum of 1'-4" (400 mm) on center horizontally and vertically (see Figure 15.8).

FIGURE 15.8: GYPSUM BOARD



# APPENDIX A: CONSTRUCTION BULLETINS

## A.1 GENERAL

The following Construction Bulletins (<https://www.nuformdirect.com/resources/conform-bulletins/>) provide additional information regarding the construction of walls using

CONFORM®. The Construction Bulletins are available on the NUFORM® website [www.nuformdirect.com](http://www.nuformdirect.com) or by contacting Nuform Building Technologies Inc. at 1-877-747-9255.

Erection		
Construction Bulletin #1	Building Layout and Foundation Dimensions	<a href="https://www.nuformdirect.com/wp-content/uploads/Construction-Bulletin-01-Building-Layout.pdf">https://www.nuformdirect.com/wp-content/uploads/Construction-Bulletin-01-Building-Layout.pdf</a>
Construction Bulletin #2	Sliding of Components	<a href="https://www.nuformdirect.com/wp-content/uploads/Construction-Bulletin-02-Sliding-of-Components.pdf">https://www.nuformdirect.com/wp-content/uploads/Construction-Bulletin-02-Sliding-of-Components.pdf</a>
Construction Bulletin #3	Wall Dimensions vs Components Chart	<a href="https://www.nuformdirect.com/wp-content/uploads/Construction-Bulletin-03-Wall-Dimensions.pdf">https://www.nuformdirect.com/wp-content/uploads/Construction-Bulletin-03-Wall-Dimensions.pdf</a>
Construction Bulletin #10	Screws (Walls only)	<a href="https://www.nuformdirect.com/wp-content/uploads/Construction-Bulletin-10-Screws-Walls-Only.pdf">https://www.nuformdirect.com/wp-content/uploads/Construction-Bulletin-10-Screws-Walls-Only.pdf</a>
Construction Bulletin #11	Construction Materials	<a href="https://www.nuformdirect.com/wp-content/uploads/Construction-Bulletin-11-Construction-Materials.pdf">https://www.nuformdirect.com/wp-content/uploads/Construction-Bulletin-11-Construction-Materials.pdf</a>
Construction Bulletin #12	Tools and Equipment	<a href="https://www.nuformdirect.com/wp-content/uploads/Construction-Bulletin-12-Tools-and-Equipment.pdf">https://www.nuformdirect.com/wp-content/uploads/Construction-Bulletin-12-Tools-and-Equipment.pdf</a>
Construction Bulletin #13	Bracing Requirements	<a href="https://www.nuformdirect.com/wp-content/uploads/Construction-Bulletin-13-Bracing-Requirements.pdf">https://www.nuformdirect.com/wp-content/uploads/Construction-Bulletin-13-Bracing-Requirements.pdf</a>
Construction Bulletin #14	Structural Steel for CF8i Wall	<a href="https://www.nuformdirect.com/wp-content/uploads/Construction-Bulletin-14-Structural-Steel-for-CF8i-Wall.pdf">https://www.nuformdirect.com/wp-content/uploads/Construction-Bulletin-14-Structural-Steel-for-CF8i-Wall.pdf</a>
Construction Bulletin #15	Starter Installation	<a href="https://www.nuformdirect.com/wp-content/uploads/Construction-Bulletin-15-Starter-Installation.pdf">https://www.nuformdirect.com/wp-content/uploads/Construction-Bulletin-15-Starter-Installation.pdf</a>
Construction Bulletin #16	Water Resistance	<a href="https://www.nuformdirect.com/wp-content/uploads/Construction-Bulletin-16-Water-Resistance.pdf">https://www.nuformdirect.com/wp-content/uploads/Construction-Bulletin-16-Water-Resistance.pdf</a>
Construction Bulletin #17	Construction Checklists	<a href="https://www.nuformdirect.com/wp-content/uploads/Construction-Bulletin-17-Construction-Checklists.pdf">https://www.nuformdirect.com/wp-content/uploads/Construction-Bulletin-17-Construction-Checklists.pdf</a>
Construction Bulletin #20	Site Cut Openings	<a href="https://www.nuformdirect.com/wp-content/uploads/Construction-Bulletin-20-Site-Cut-Openings.pdf">https://www.nuformdirect.com/wp-content/uploads/Construction-Bulletin-20-Site-Cut-Openings.pdf</a>

Concrete		
Construction Bulletin #4	Cold Weather Requirements	<a href="https://www.nuformdirect.com/wp-content/uploads/Construction-Bulletin-04-Cold-Weather-Requirements.pdf">https://www.nuformdirect.com/wp-content/uploads/Construction-Bulletin-04-Cold-Weather-Requirements.pdf</a>
Construction Bulletin #6	Hot Weather Requirements	<a href="https://www.nuformdirect.com/wp-content/uploads/Construction-Bulletin-06-Hot-Weather-Requirements.pdf">https://www.nuformdirect.com/wp-content/uploads/Construction-Bulletin-06-Hot-Weather-Requirements.pdf</a>
Construction Bulletin #8	Consolidation of Concrete in CONFORM	<a href="https://www.nuformdirect.com/wp-content/uploads/Construction-Bulletin-08-Consolidation-of-Concrete.pdf">https://www.nuformdirect.com/wp-content/uploads/Construction-Bulletin-08-Consolidation-of-Concrete.pdf</a>

Finishing		
Construction Bulletin #5	Insulation Options	<a href="https://www.nuformdirect.com/wp-content/uploads/Construction-Bulletin-05-Insulation-Options.pdf">https://www.nuformdirect.com/wp-content/uploads/Construction-Bulletin-05-Insulation-Options.pdf</a>
Construction Bulletin #7	Wall Patching Procedures	<a href="https://www.nuformdirect.com/wp-content/uploads/Construction-Bulletin-07-Wall-Patching-Procedures.pdf">https://www.nuformdirect.com/wp-content/uploads/Construction-Bulletin-07-Wall-Patching-Procedures.pdf</a>
Construction Bulletin #9	Hollow Metal Door Installation	<a href="https://www.nuformdirect.com/wp-content/uploads/Construction-Bulletin-09-Hollow-Metal-Doors-and-Frames.pdf">https://www.nuformdirect.com/wp-content/uploads/Construction-Bulletin-09-Hollow-Metal-Doors-and-Frames.pdf</a>
Construction Bulletin #18	Cleaning and Maintenance	<a href="https://www.nuformdirect.com/wp-content/uploads/Construction-Bulletin-18-Cleaning-and-Maintenance.pdf">https://www.nuformdirect.com/wp-content/uploads/Construction-Bulletin-18-Cleaning-and-Maintenance.pdf</a>
Construction Bulletin #19	CF8i Exterior Face Repair	<a href="https://www.nuformdirect.com/wp-content/uploads/Construction-Bulletin-19-CF8i-Exterior-Face-Repair.pdf">https://www.nuformdirect.com/wp-content/uploads/Construction-Bulletin-19-CF8i-Exterior-Face-Repair.pdf</a>

# APPENDIX B: BRACING FOR CONFORM®

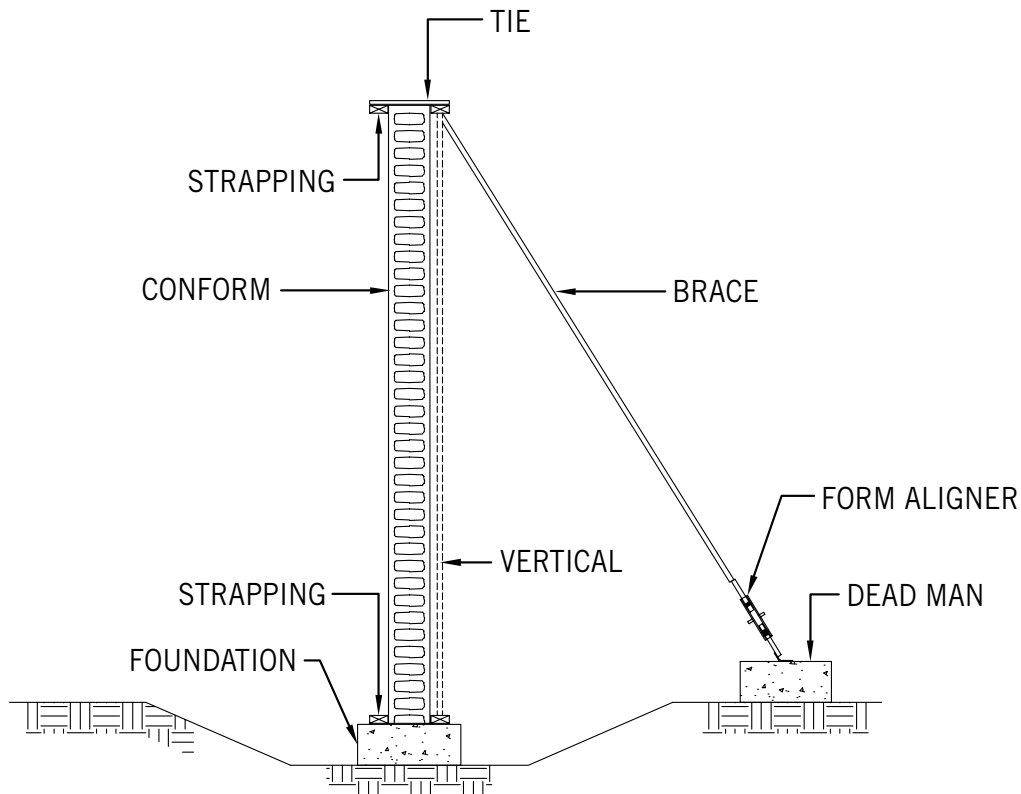
## B.1 GENERAL

1. All bracing for CONFORM® must be designed by the contractor in accordance with the applicable safety rules and regulations, the local building codes and the governing authorities<sup>(1)</sup>. Refer to the Engineering Guide ([https://www.nuformdirect.com/wp-content/uploads/Engineering\\_Guide\\_v2.0.pdf](https://www.nuformdirect.com/wp-content/uploads/Engineering_Guide_v2.0.pdf)).
2. The most effective means of achieving safety in the use of CONFORM is to have competent supervision during erection and placement of concrete. All activities must be designed, supervised and inspected to ensure that the construction is completed in a safe manner.
3. The most frequent cause of bracing

failure is an effect that introduces lateral forces or induces displacement in supporting members. Inadequate cross bracing and horizontal bracing is one of the factors most frequently involved in bracing failure. Even when the basic bracing design is soundly conceived the lack of attention to bracing details and small differences in assembly may cause local weakness or overstress that leads to failure of the bracing.

4. All bracing for CONFORM must remain in place until the roof connections and/or lateral diaphragms are installed to the poured concrete walls.
5. The use of scaffolding for bracing of CONFORM is not recommended.

FIG B1 TYPICAL BRACING MEMBERS

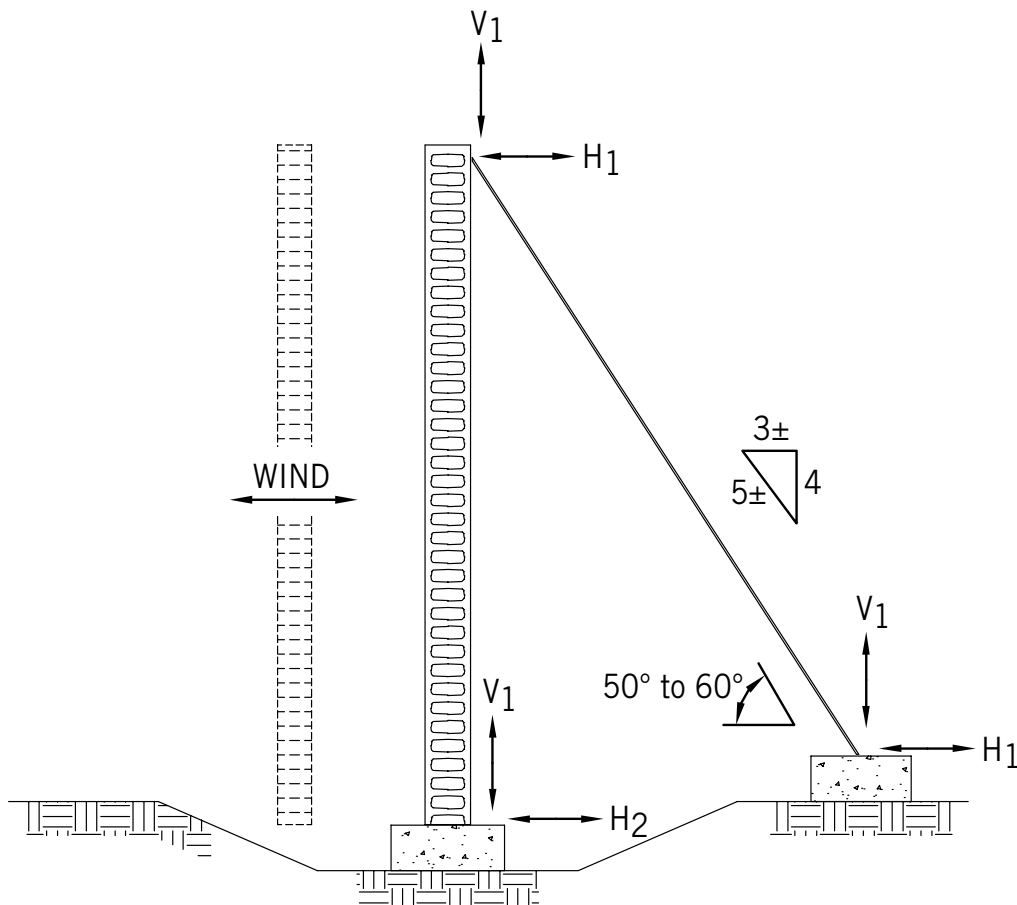


(2) The bracing illustrated in this guide provides general suggestions only. The contractor is solely responsible to ensure that all erection and bracing is completed in a safe manner. NUFORM does not assume any liability for the erection and bracing.

## B.2 BRACING DESIGN GUIDELINES

1. Bracing for wind loads should be determined by an experienced bracing designer to meet the requirements of the specific project and site conditions.
2. Generally, bracing is designed for a 110 km/h (70 mph) wind based on a 5 year mean occurrence and for a load of not less than 0.48 kPa (10 psf).
3. The factors of safety recommended for the design of bracing are 1.5 for the members and 2.0 for the connections.
4. Typically, braces are placed at an angle between  $50^\circ$  and  $60^\circ$ , i.e. the horizontal dimension is between 75% and 50% of the vertical height.
5. Strong-backs, cross-bridging, or knee braces are installed on long braces to ensure that the braces do not buckle under load.
6. Deadmen or a foundation slab are required to anchor all braces.
7. A form aligner or turnbuckle is recommended at one end of each brace for ease of plumbing and aligning CONFORM.

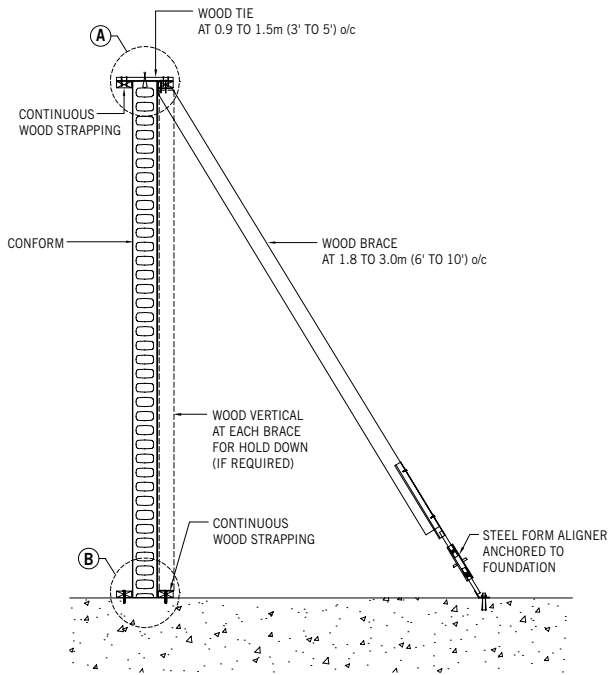
FIG B2 BRACING FORCE DIAGRAM



### B.3 SINGLE BRACING

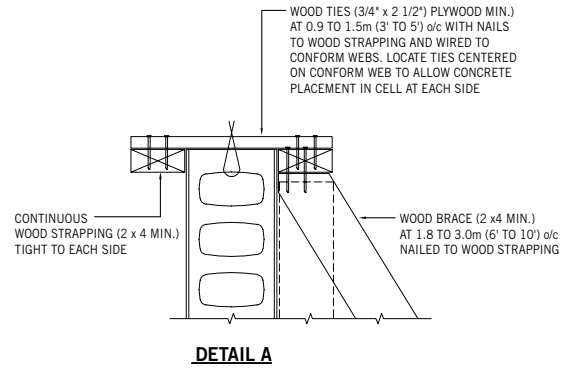
1. Single bracing consists of strapping at the top and bottom of CONFORM and diagonal braces at 1.8 to 3.0 m (6' to 10') on center, to the top of CONFORM.

**FIG B3-1 SINGLE WOOD BRACING WITH STRAPPING ON BOTH SIDES**

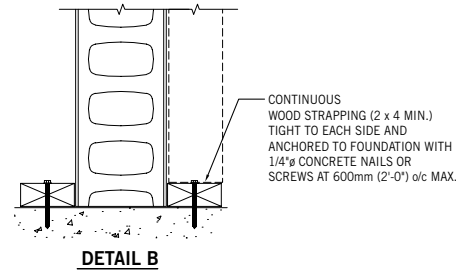


2. The following figures illustrate single wood bracing with strapping on both sides.

**FIG B3-1A SINGLE WOOD BRACING WITH STRAPPING ON BOTH SIDES - TOP DETAIL**



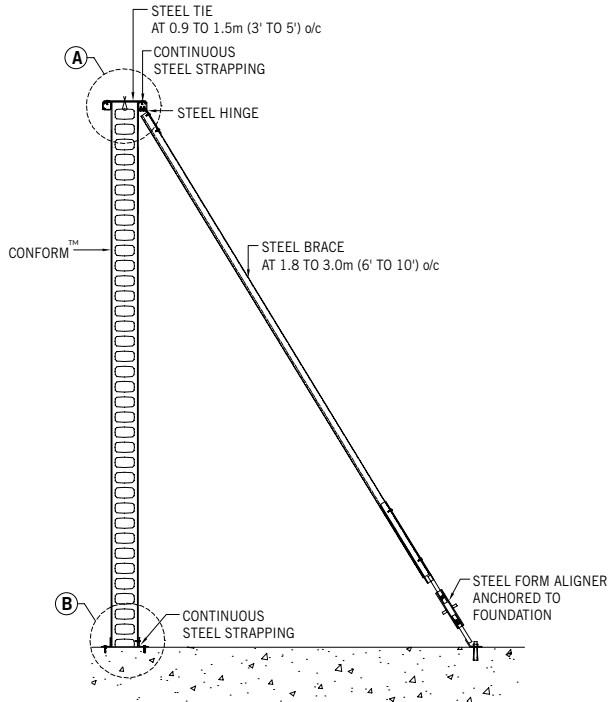
**FIG B3-1B SINGLE WOOD BRACING WITH STRAPPING ON BOTH SIDES - BOTTOM DETAIL**



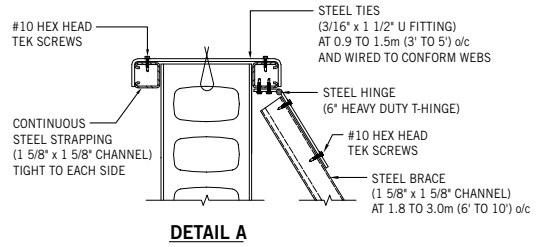


3. The following figures illustrate single steel bracing with strapping on both sides.

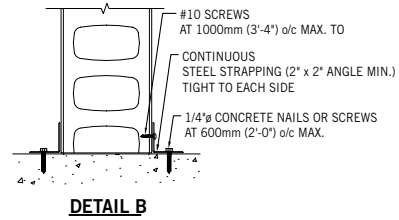
**FIG B3-2 SINGLE STEEL BRACING WITH STRAPPING ON BOTH SIDES**



**FIG B3-2A SINGLE STEEL BRACING WITH STRAPPING ON BOTH SIDES - TOP DETAIL**

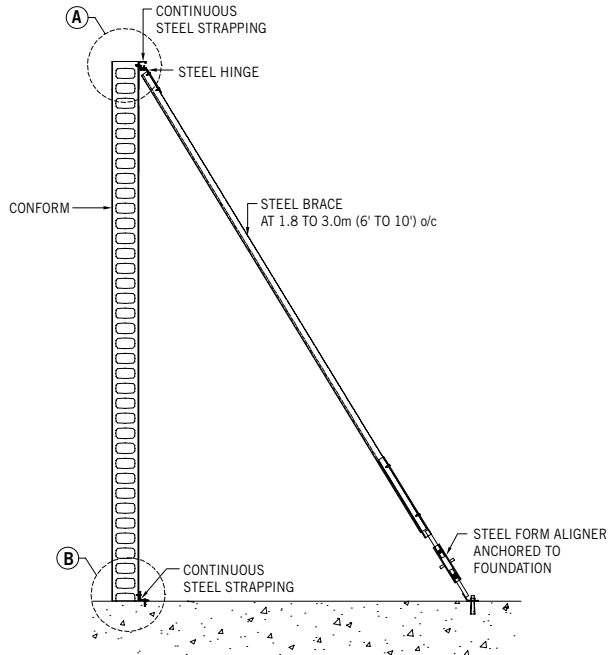


**FIG B3-2B SINGLE STEEL BRACING WITH STRAPPING ON BOTH SIDES - BOTTOM DETAIL**

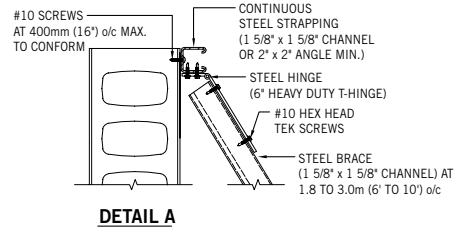


4. The following figures illustrate single steel bracing with strapping on one side only.

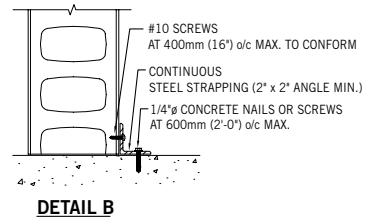
**FIG B3-3 SINGLE STEEL BRACING WITH STRAPPING ON ONE SIDE**



**FIG B3-3A SINGLE STEEL BRACING WITH STRAPPING ON ONE SIDE - TOP DETAIL**



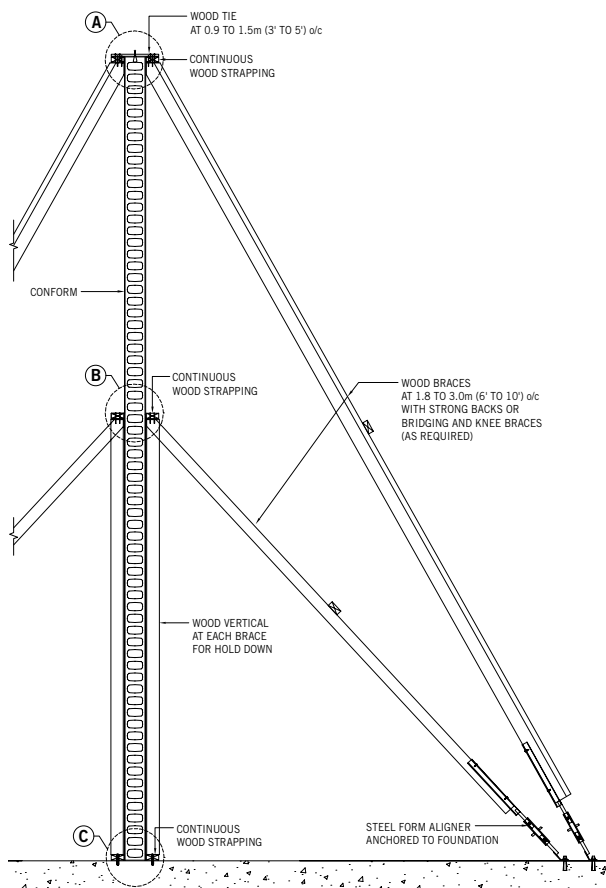
**FIG B3-3A SINGLE STEEL BRACING WITH STRAPPING ON ONE SIDE - TOP DETAIL**



## B.4 DOUBLE BRACING

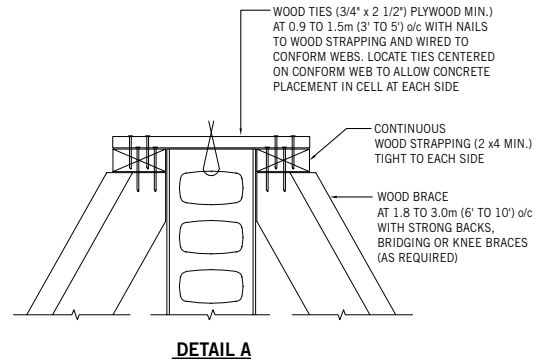
1. Double bracing consists of strapping at the top, bottom and mid-height of CONFORM and diagonal braces at 1.8 to 3.0 m (6' to 10') on center, to the top and mid-height of CONFORM.
2. Horizontal strapping and braces are provided near mid-height of CONFORM to maintain the plumb of the walls, to resist construction loads during placement of concrete and to resist lateral wind loads. For walls with staggered joints the mid-height bracing is placed along one of the joints.
3. Double bracing is required for locations with large wind loads or projects with high walls. Typically, this applies to CF4 forms over 4 m (13'), CF6 forms over 5 m (16') and CF8 or CF8i forms over 5.5 m (18').

**FIG B4-1 DOUBLE WOOD BRACING WITH STRAPPING ON BOTH SIDES**

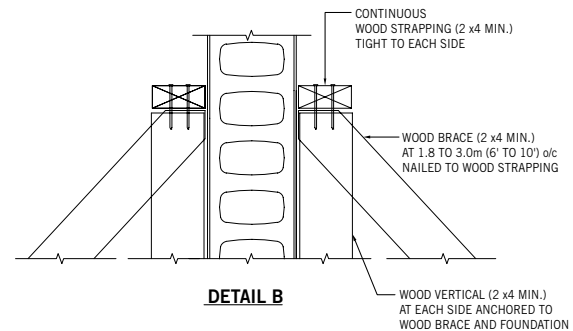


4. The following figures illustrate double wood bracing with strapping on both sides.

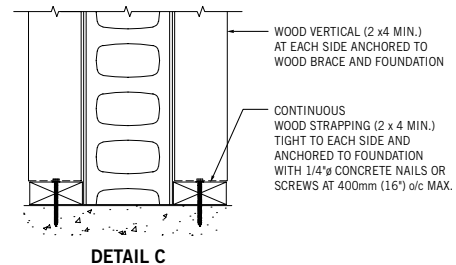
**FIG B4-1A DOUBLE WOOD BRACING WITH STRAPPING ON BOTH SIDES - TOP DETAIL**



**FIG B4-1B DOUBLE WOOD BRACING WITH STRAPPING ON BOTH SIDES - MID-HEIGHT DETAIL**

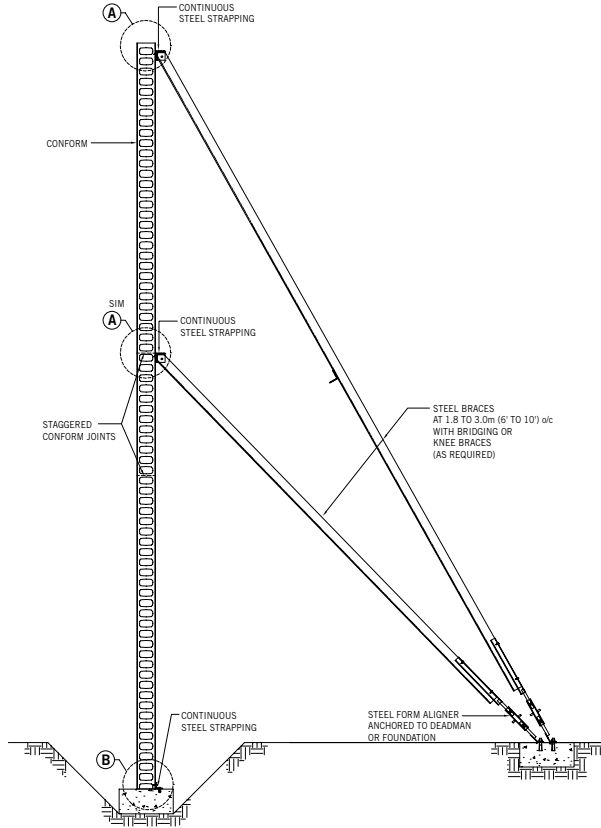


**FIG B4-1C DOUBLE WOOD BRACING WITH STRAPPING ON BOTH SIDES - BOTTOM DETAIL**

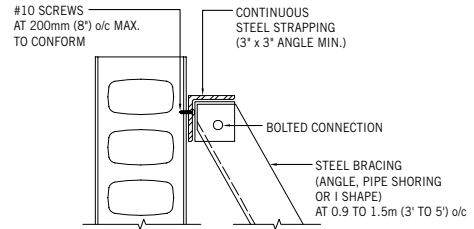


5. The following figures illustrate double steel bracing with steel members on one side.

**FIG B4-2 DOUBLE STEEL BRACING WITH STRAPPING ON ONE SIDE**

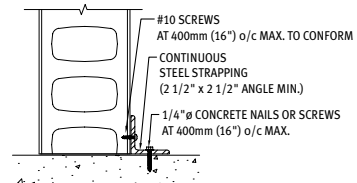


**FIG B4-2A DOUBLE STEEL BRACING WITH STRAPPING ON ONE SIDE - TOP AND MID-HEIGHT DETAIL**



**DETAIL A**

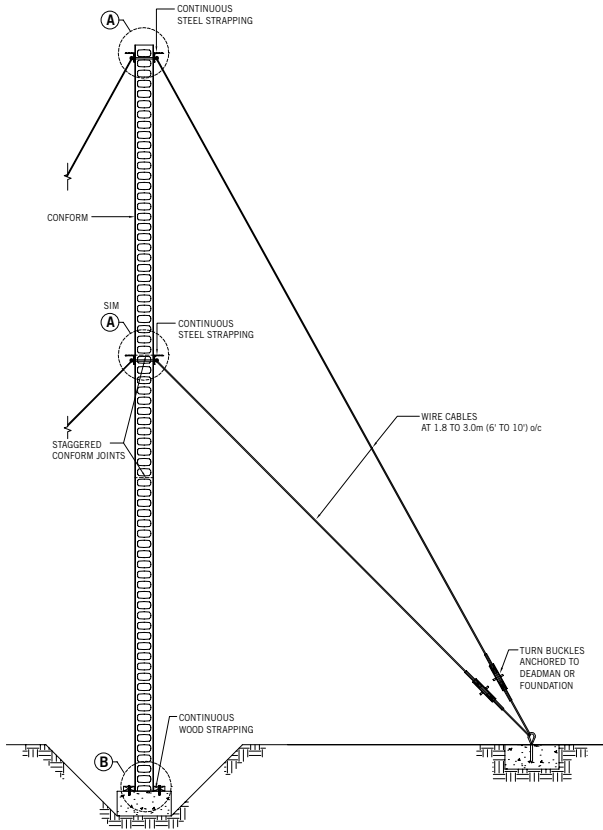
**FIG B4-2B DOUBLE STEEL BRACING WITH STRAPPING ON ONE SIDE - BOTTOM DETAIL**



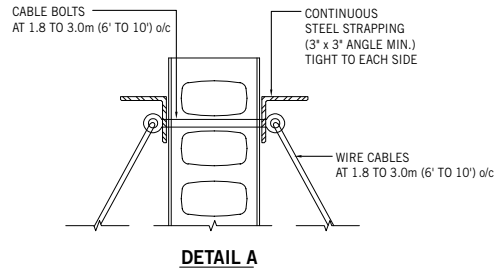
**DETAIL B**

6. The following figures illustrate double cable bracing with strapping on both sides.

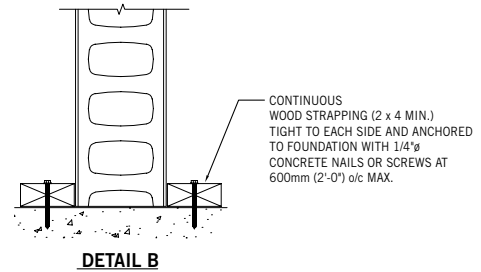
**FIG B4-3 DOUBLE CABLE BRACING WITH STRAPPING ON BOTH SIDES**



**FIG B4-3A DOUBLE CABLE BRACING WITH STRAPPING ON BOTH SIDES - TOP AND MID-HEIGHT DETAIL**



**FIG B4-3B DOUBLE CABLE BRACING WITH STRAPPING ON BOTH SIDES - BOTTOM DETAIL**



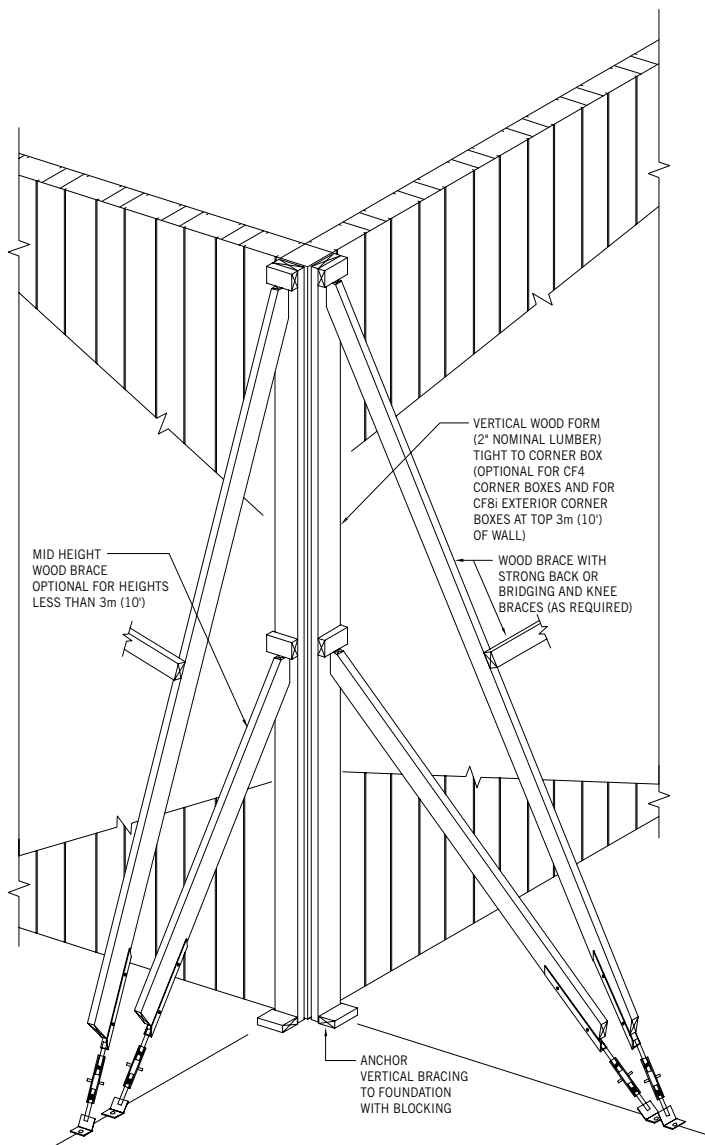
## B.5 VERTICAL BRACING AT CORNERS, T-INTERSECTIONS AND ENDS

1. When the concrete is poured into the cells of the CONFORM components, it flows a maximum of 1.2 m (4') laterally from the cell in which it is placed and hydrostatic pressures are exerted on the webs of the cells. The resulting forces in the plane of the wall must be resisted by vertical and diagonal bracing at corners, intersections and ends of walls in order to maintain CONFORM square and plumb. The vertical bracing is connected to the

foundation and is laterally supported with diagonal bracing at the top and at 1.5 to 2 m (5' to 7') on center.

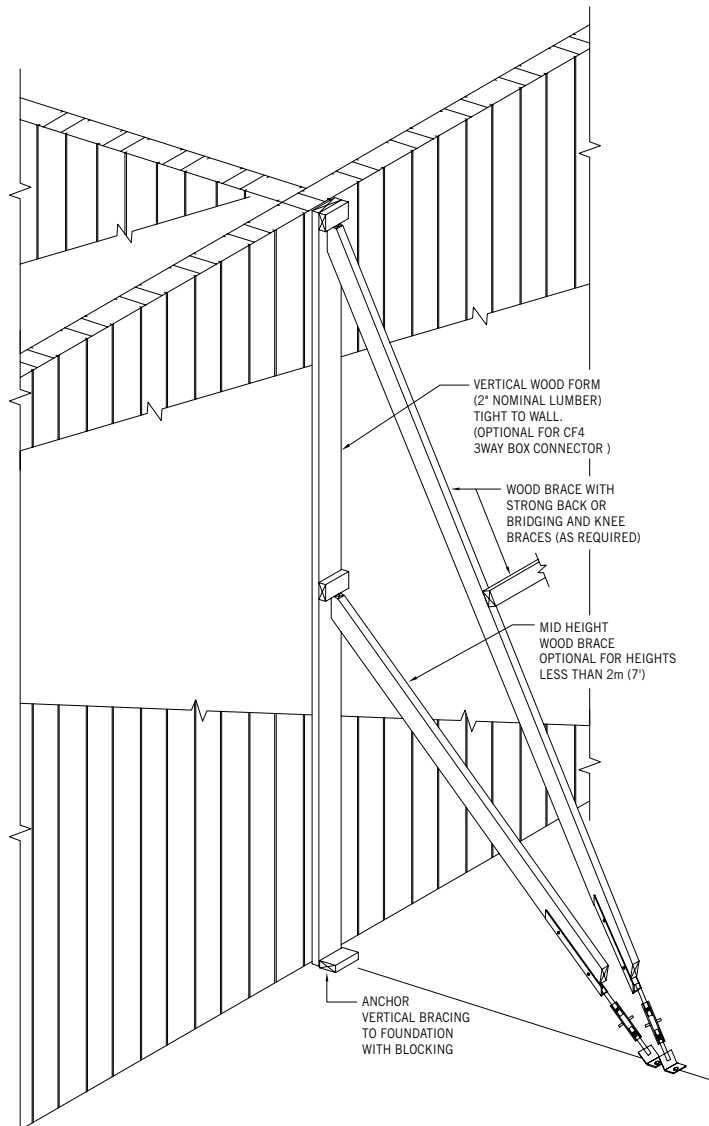
2. Vertical bracing with diagonal braces is placed both ways at the corners of walls. This is to prevent bowing of the form face, to hold the face of CONFORM plumb and to prevent expansion or shifting of CONFORM during placement of concrete.

FIG B5-1 VERTICAL CORNER BRACING



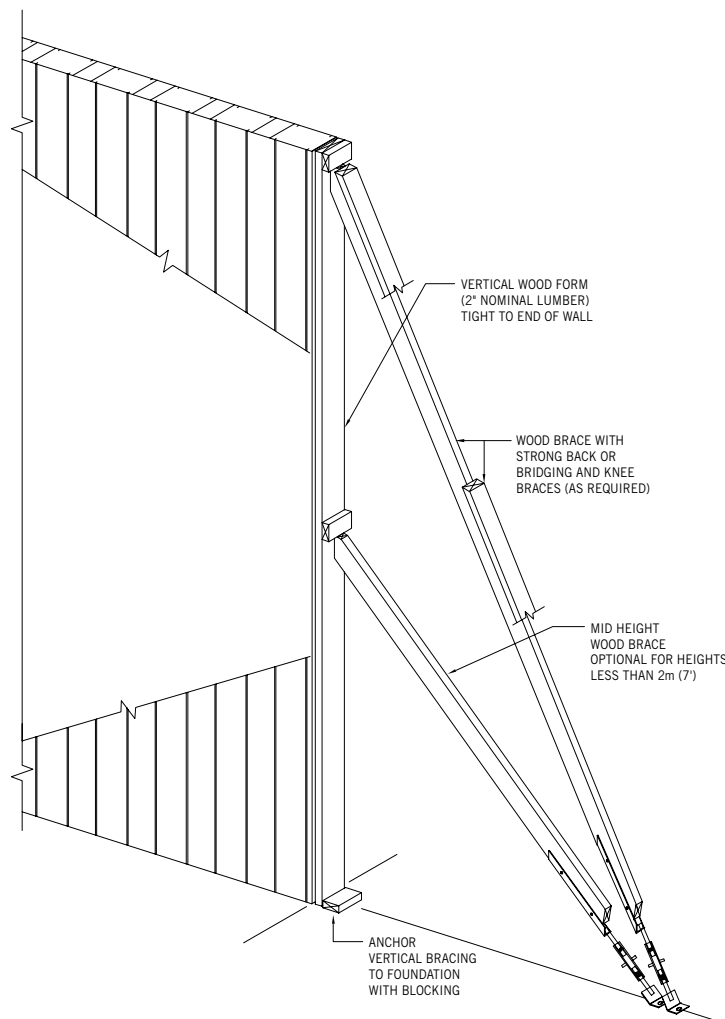
3. Vertical bracing is placed at intersections that use starters and box joiners. Diagonal braces are connected at the top and mid-height of CONFORM. This is to prevent bowing of the form face, to hold the face of CONFORM plumb, to prevent expansion or shifting of CONFORM and to hold the starter or box joiner tight to the other components during placement of concrete.

**FIG B5-2 VERTICAL TEE INTERSECTION BRACING**



4. Vertical bracing is placed at ends of walls. Diagonal braces are connected at the top and mid-height of CONFORM. This is to prevent bowing of the form face, to hold the face of CONFORM plumb and to prevent expansion or shifting of CONFORM during placement of concrete.

**FIG B5-3 VERTICAL END BRACING**





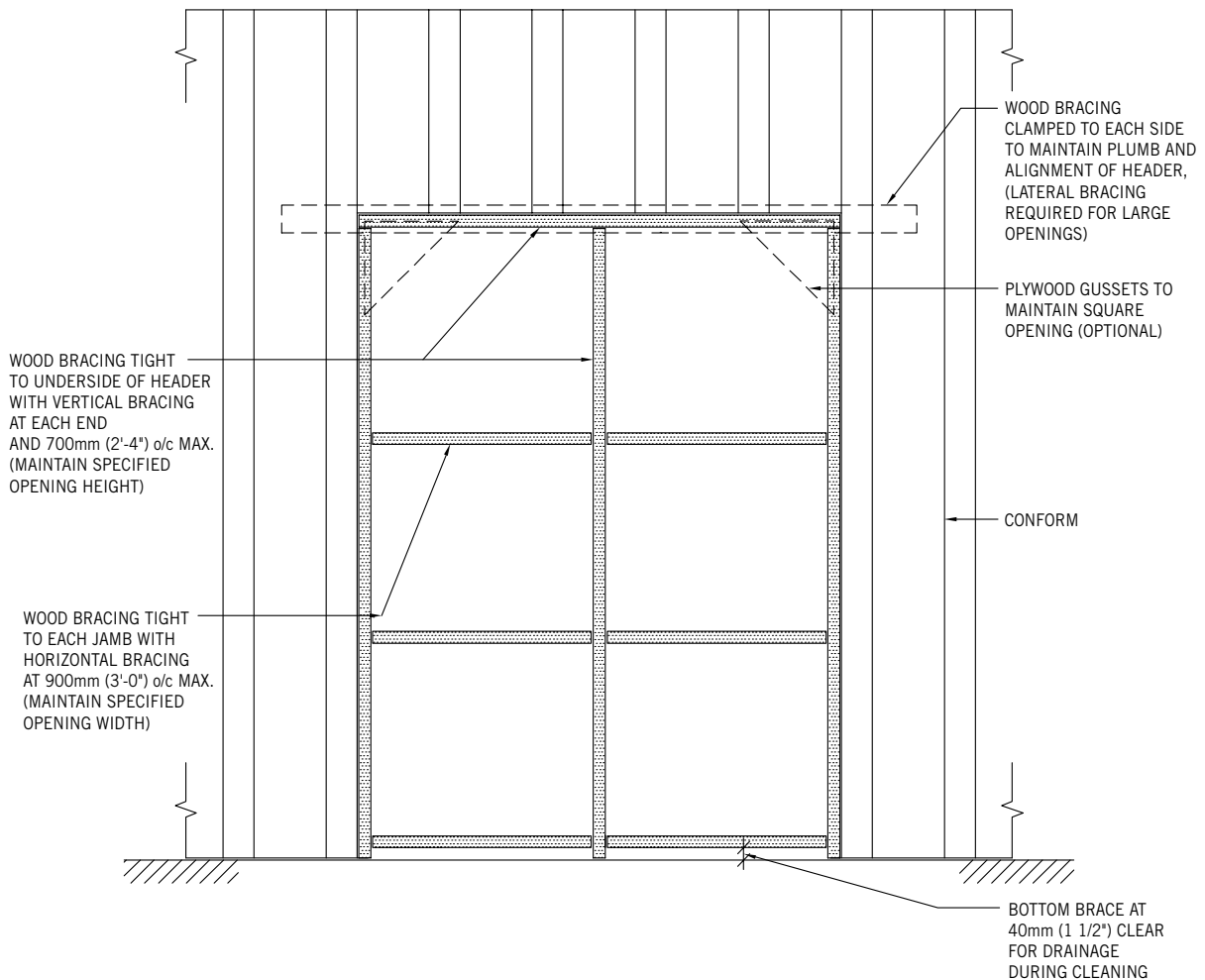
## B.6 BRACING AT OPENINGS

1. Bracing is required at openings to keep the opening square, to prevent bowing of jambs and to contain and support the wet concrete in the header during concrete placement.
2. For large openings, diagonal bracing is required at the top and bottom of the

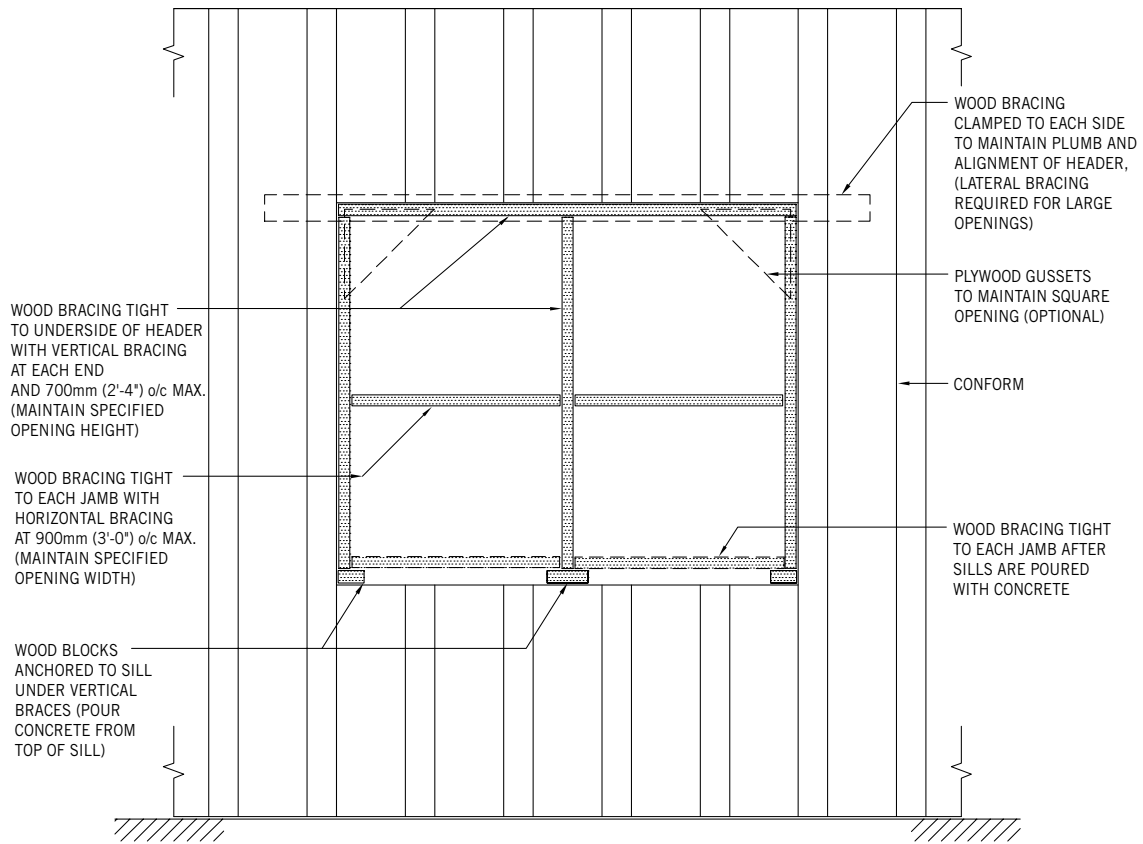
headers to hold the header straight and plumb and to hold the header flush with the wall at each end of the header.

3. For openings adjacent to corners and piers between openings the horizontal bracing for the jambs can be achieved by clamping.

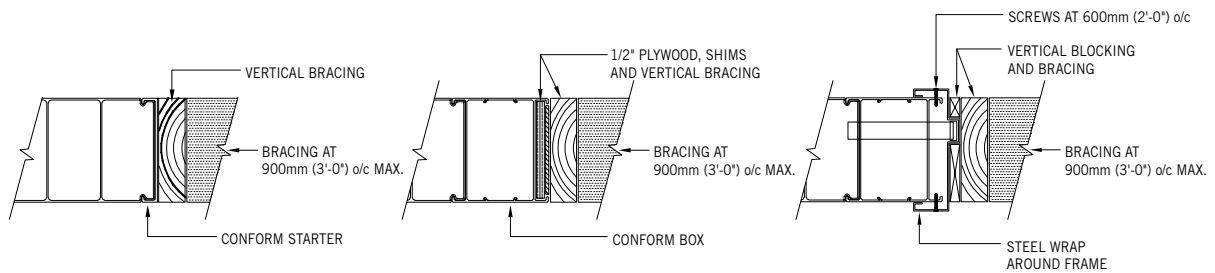
FIG B6-1 DOOR BRACING



**FIG B6-2 WINDOW BRACING**



**FIG B6-3 OPENING DETAILS**

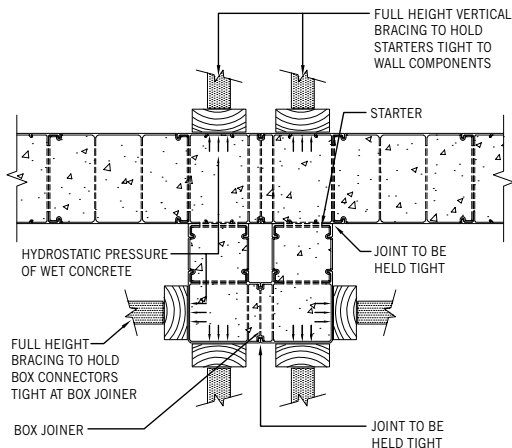


## B.7 BRACING AT PIERS, COLUMNS AND DOUBLE WALLS

1. Additional bracing is required at pilasters that are created using CONFORM components. The concrete pressure is exerted at the outmost faces and will create tension through all interconnecting pieces. During concrete placement, starters

may pull away from an adjoining wall and box joiners may not be adequate to hold two box connectors together. Additional bracing is provided to resist the tension that is created and hold the CONFORM components straight and plumb.

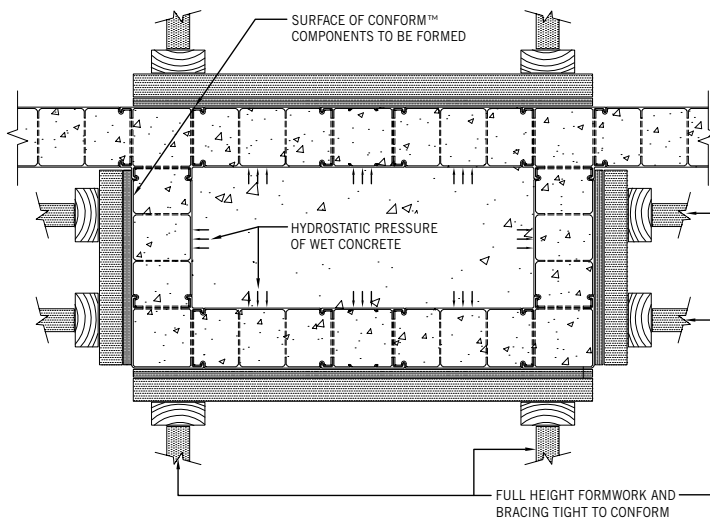
FIG B7-1 PILASTER BRACING



2. Additional bracing is required at columns and double walls where concrete is placed between two layers of CONFORM. An entire CONFORM panel or section of wall may bow when concrete is placed between two layers of CONFORM. Bracing is provided to resist the hydrostatic

pressures of the wet concrete between the two walls and to hold the entire CONFORM straight and plumb during concrete placement. Alternately, concrete is placed in the CONFORM components only and allowed to set prior to placing concrete between the two layers of CONFORM.

FIG B7-2 COLUMN AND DOUBLE WALL BRACING



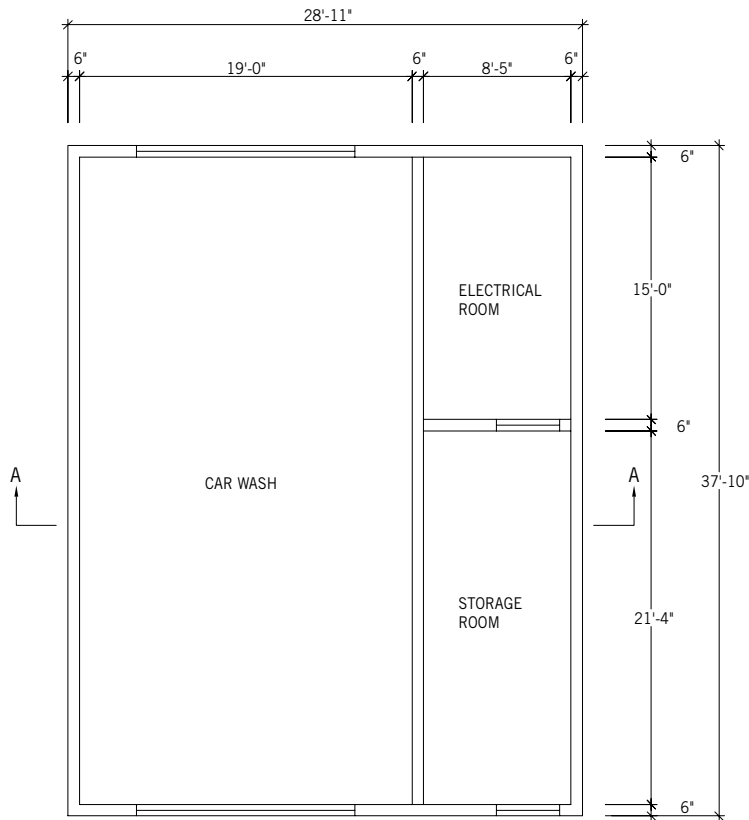
## B.8 BRACING EXAMPLE

1. This example illustrates the bracing layout for a simple project

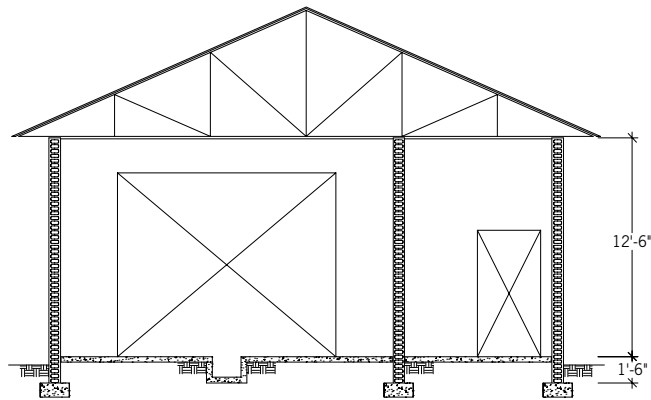
- Car Wash Building - 28'-11" x 37'-10".
- Wall height - 14'-0" (12'-6" above grade and 1'-6" below grade).

- Concrete walls using CF6 forms - 6" thick, as specified to meet structural requirements.
- Finished wall surface is CONFORM exposed full height on both sides.

FIG B8-1 PROJECT LAYOUT



### PLAN



### SECTION A-A

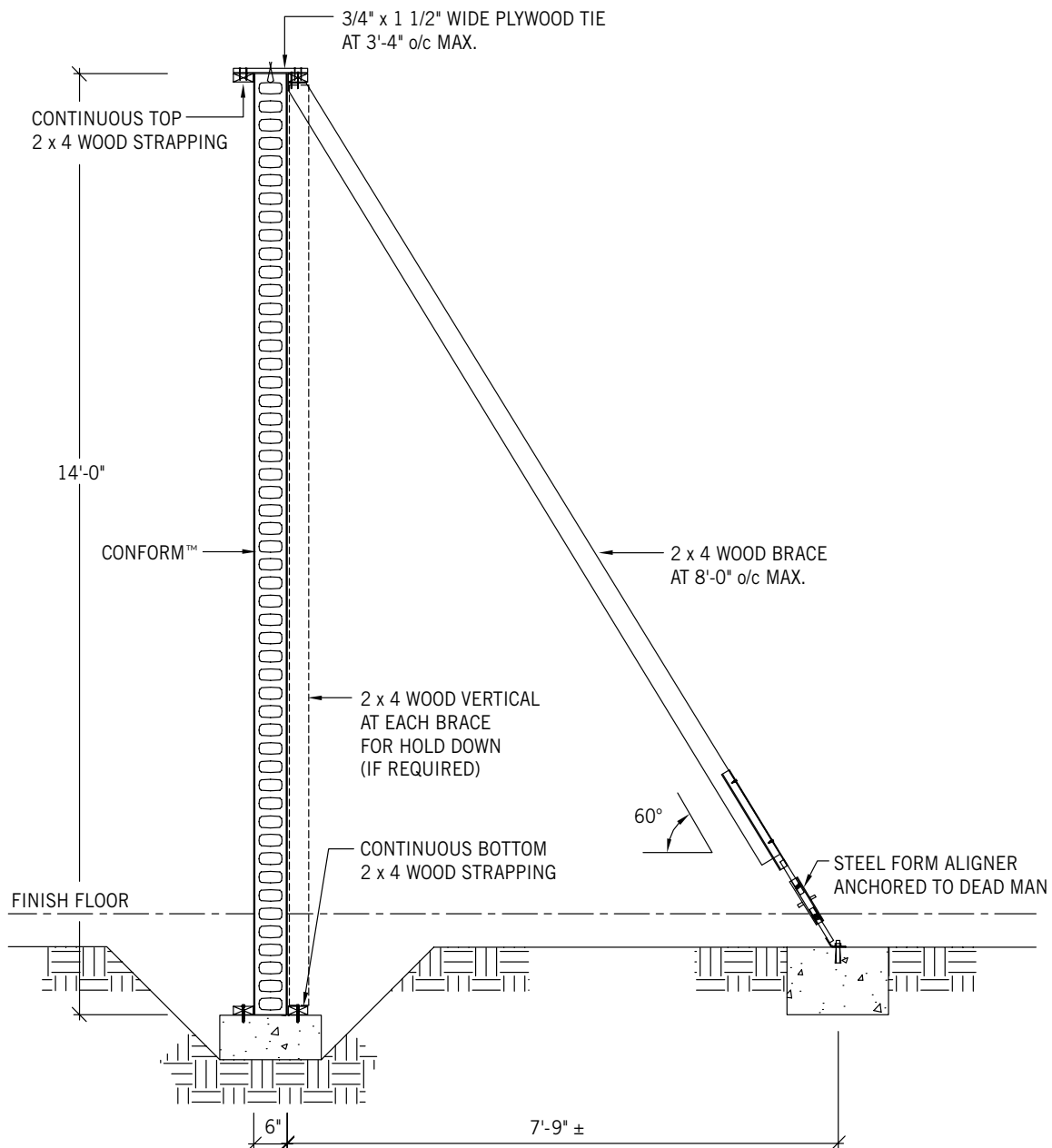
**2. Select Erection Method (Refer to Section 2.3 of this guide)**

- Erection using individual components is selected due to small size of structure, 14' wall height, site conditions and available equipment.
- Starting corner is selected due to site conditions and contractor's preference.

**3. Select Bracing Method (Refer to Section B.3 of this guide)**

- Single bracing is selected due to 14' wall height.
- Wood bracing is selected due to available materials
- Strapping on both sides is selected since CONFORM will be the exposed finished wall surface.





**FIG B8-2 BRACING SECTION**

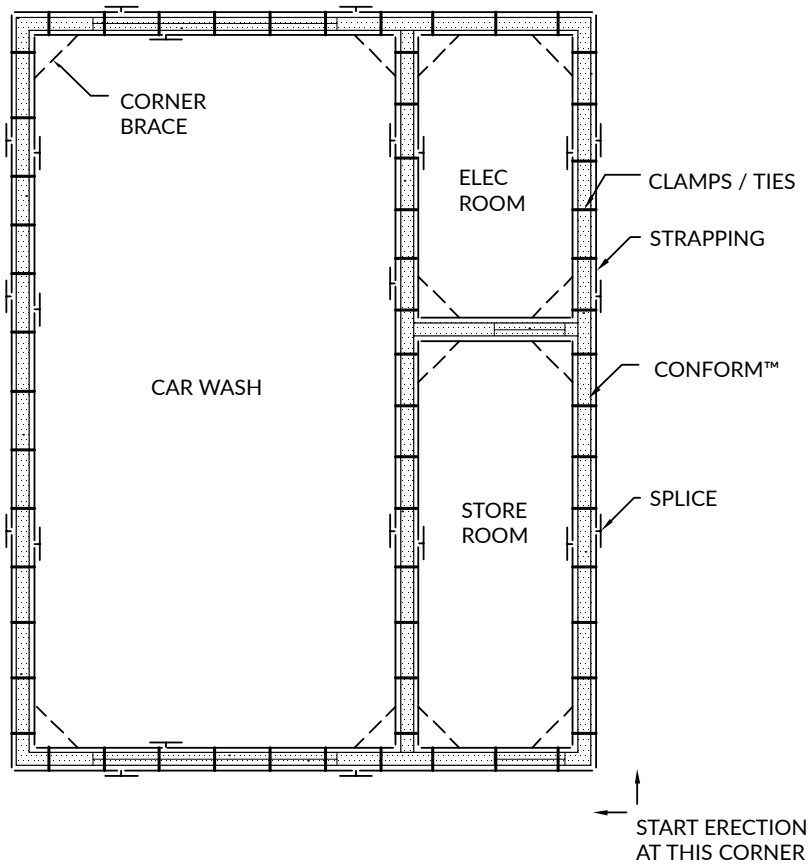


#### 4. Prepare Bracing Layout

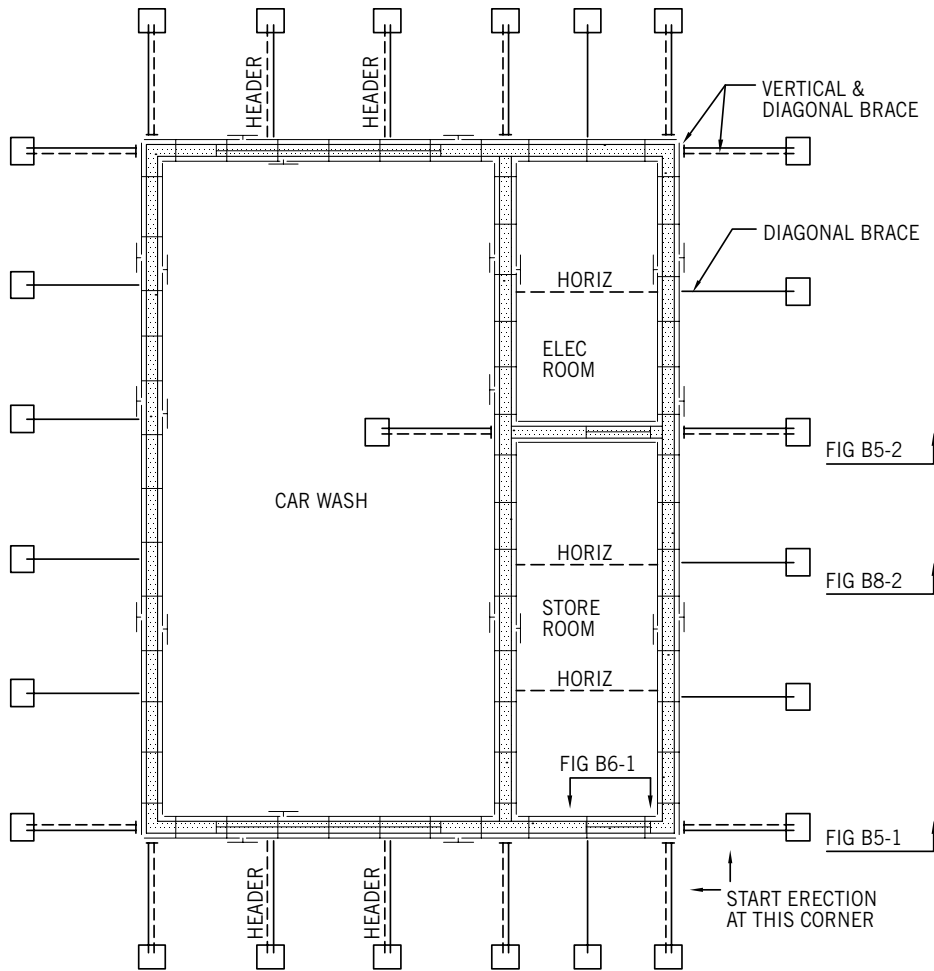
- Layout strapping on both sides at top and bottom, based on 2x4 lumber by 12' long. Joints are staggered 1'-0" minimum and spliced.
- Layout clamps and/or horizontal ties at 3'-4" maximum at top strapping. Corners are provided with diagonal ties.
- Layout vertical and diagonal bracing at corners and intersections.
- Layout diagonal bracing to the top strapping at 8' maximum or provide horizontal ties to adjacent diagonal wall bracing.
- Layout diagonal bracing to underside of headers over long openings.

**FIG B8-3A PRELIMINARY BRACING LAYOUT**

LEGEND	DESCRIPTION
	CONTINUOUS TOP 2 X 4 WOOD STRAPPING
	2 X 4 WOOD SPLICE AT STRAPPING
	WOOD CLAMP AND/OR 3/4" X 1 1/2" PLYWOOD TIE
	2 X 4 WOOD CORNER BRACING



LEGEND	DESCRIPTION
	2 x 6 WOOD VERTICAL & DIAGONAL 2 x 4 WOOD BRACE AT CORNERS AND INTERSECTIONS
	DIAGONAL 2 x 4 WOOD BRACE TO TOP WALLS AT 8'-0" o/c MAX.
	HORIZONTAL 2 x 4 WOOD BRACE AT 8'-0" o/c MAX.
	DIAGONAL 2 x 4 WOOD BRACE TO UNDERSIDE HEADER AT 8'-0" MAX.



**FIG B8-3B PRELIMINARY BRACING LAYOUT**

**5. Verify Bracing Layout and Member Sizes based on Engineering Analysis of Bracing Requirements**

- Calculate design loads for bracing based on local climatic conditions and requirements of regulatory authorities.
- Verify the load capacity for all bracing members based on assumed member sizes and spacing. Revise member sizes and spacing as required.
- Determine the connections required between bracing members and determine the anchorage or deadmen required for the diagonal braces.
- Determine the bracing for openings based on the weight and hydrostatic pressure of the wet concrete.

We hope you found this guide informative while designing your project using CONFORM®.

As always, our main goal at Nuform Building Technologies Inc. is to ensure that our valued customers are 100% satisfied with our service and with CONFORM. Should you have any questions or comments, we would like to hear from you. You may contact us at the following:

Please visit the Technical Section of our web site at [www.nuformdirect.com](http://www.nuformdirect.com) for the latest version of this guide. Please forward us any suggestions or comments for improving this guide. All suggestions for improvements will be given full consideration for future revisions.

PURCHASER IS SOLELY RESPONSIBLE FOR DETERMINING THE SUITABILITY FOR USE OR APPLICATION OF ANY GOODS, INCLUDING COMPONENTS THEREOF, OR WHETHER SUCH GOODS MEET REQUIREMENTS OF APPLICABLE BUILDING CODES OR SAFETY CODES FOR SPECIFIC APPLICATIONS.

© 2023 Nuform Building Technologies Inc. All rights reserved. Reasonable efforts have been made to ensure the accuracy of this publication; however, any information and data contained herein is subject to change without notice.





The Pre-Finished, Stay-in-Place  
Concrete Wall Formwork

For more photos and information,  
visit our Web site at  
**[www.nuformdirect.com](http://www.nuformdirect.com)**



Nuform Building Technologies Inc.  
100 Galcat Drive, Unit #2  
Woodbridge, Ontario, Canada  
L4L 0B9

Toll Free: 1 877-747-WALL (9255)  
Tel.: 905-652-0001  
Fax: 905-652-0002

NUFORM, CONFORM, RELINE and the "N" logo are registered  
trademarks of Nuform Building Technologies Inc.

---

Purchaser is solely responsible for determining the suitability for use  
or application of any goods, including components thereof,  
or whether such goods meet requirements of applicable building  
codes or safety codes for specific applications.