

**HEADER SECTION**

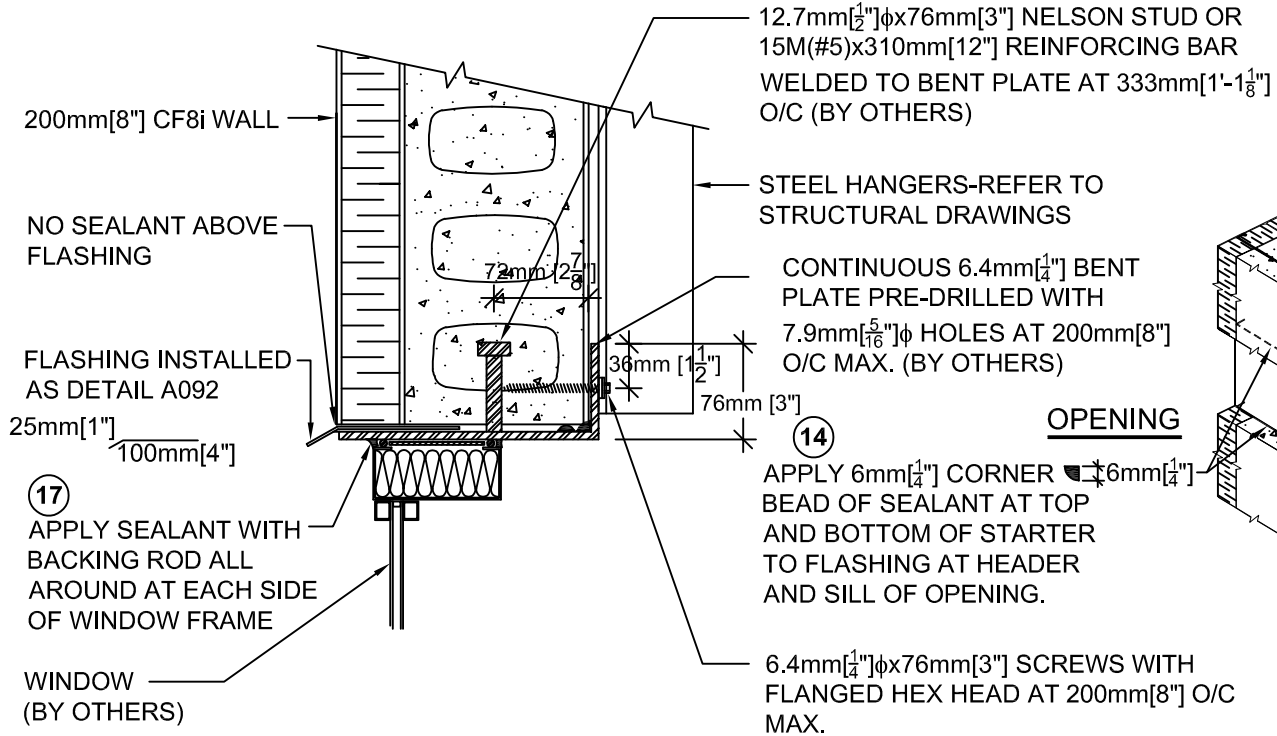

**OPENING**

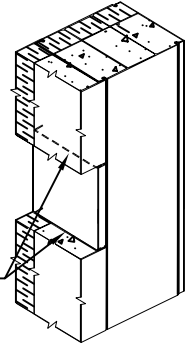

**JAMB SECTION**

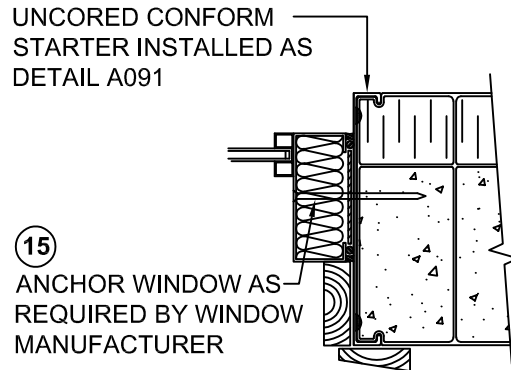

**SILL SECTION**

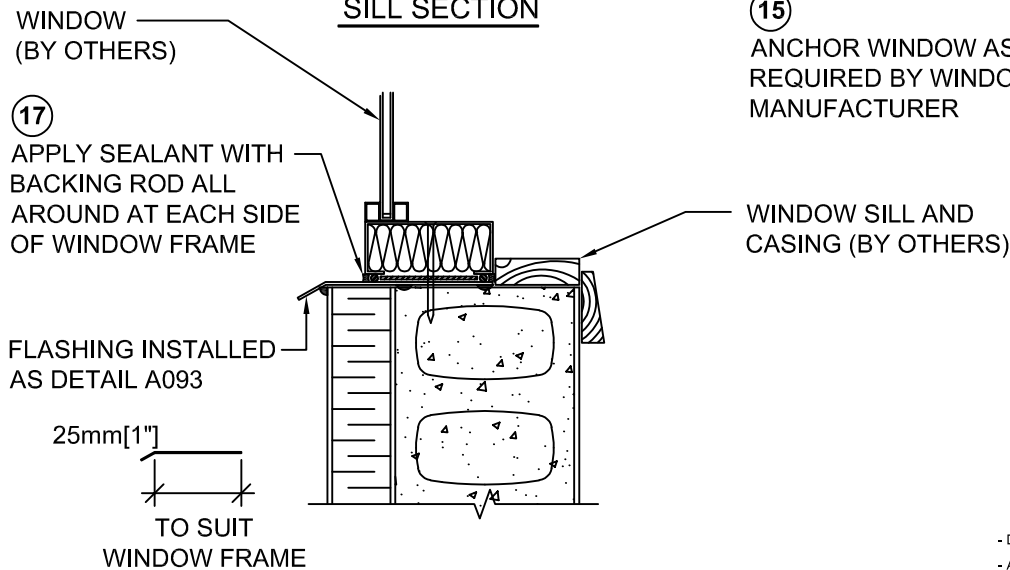

- DETAIL FOR FORMWORK ONLY  
 - ALL DETAILS, REINFORCING STEEL & CONCRETE MUST BE DESIGNED & CONFIRMED BY PROJECT STRUCTURAL ENGINEER AND / OR PROJECT ARCHITECT.



Nuform Building Technologies Inc.  
 100 Galcat Drive, Unit #2,  
 Woodbridge, Ontario, Canada L4L 0B9  
 Tel: 905-652-0001 Fax: 905-652-0002  
 Toll Free: 1-877-747-9255  
 Web Page: www.nuformdirect.com

**200mm[8"] CF8i WALL - WINDOW HEADER ANGLE**



DRAWING NO.		<b>A226</b>	
COPYRIGHT 2024			
SCALE:	REVISION No.:		
	<b>R00</b>		