

HEADER SECTION

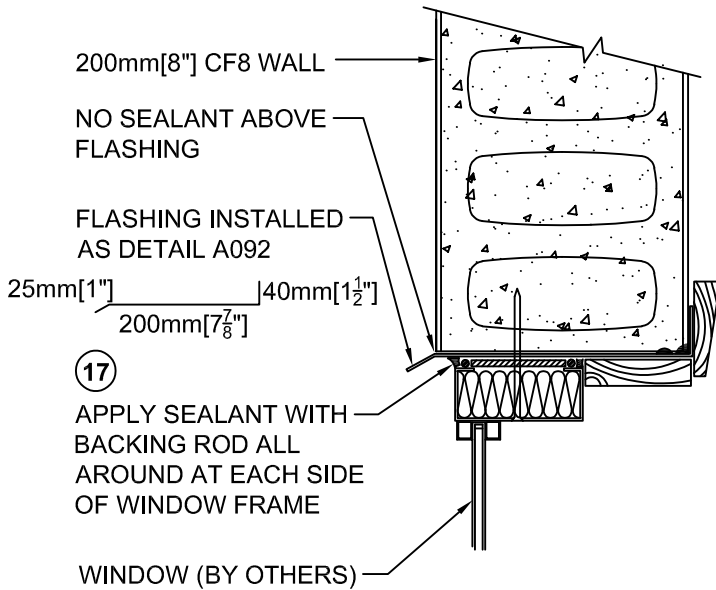

OPENING

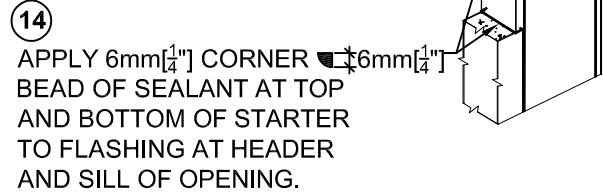

JAMB SECTION

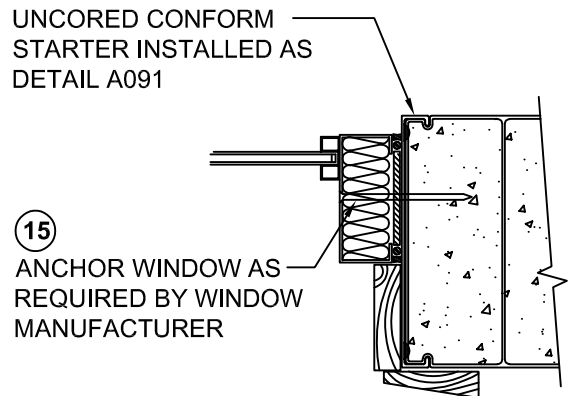

SILL SECTION

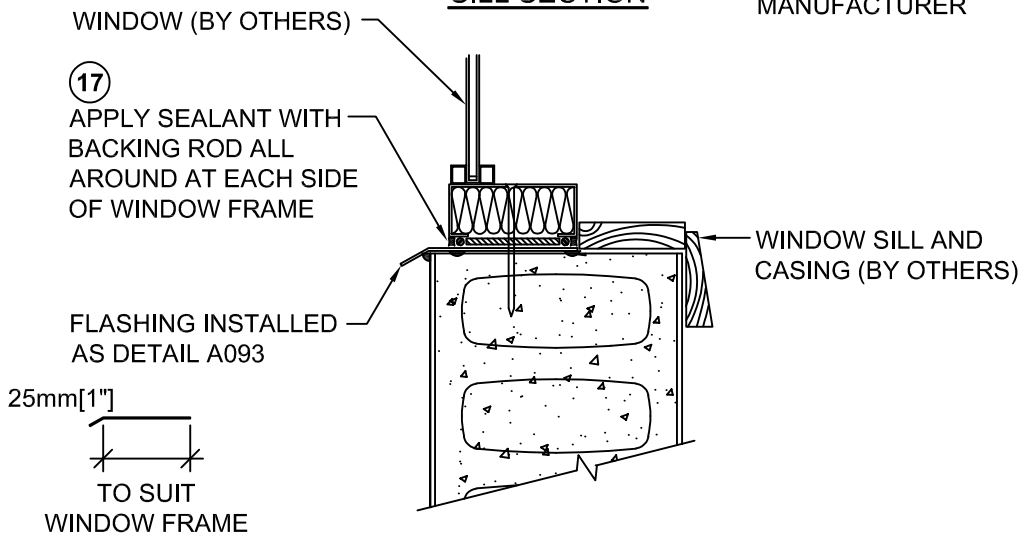

- DETAIL FOR FORMWORK ONLY
 - ALL DETAILS, REINFORCING STEEL & CONCRETE MUST BE DESIGNED & CONFIRMED BY PROJECT STRUCTURAL ENGINEER AND / OR PROJECT ARCHITECT.



Nuform Building Technologies Inc.
 100 Galcat Drive, Unit #2,
 Woodbridge, Ontario, Canada L4L 0B9
 Tel: 905-652-0001 Fax: 905-652-0002
 Toll Free: 1-877-747-9255
 Web Page: www.nuformdirect.com

**200mm[8"] CF8 WALL -
 HOLLOW METAL WINDOW**



DRAWING NO.	
A223	
COPYRIGHT 2024	
SCALE:	REVISION No.:
	R00