

HEADER SECTION

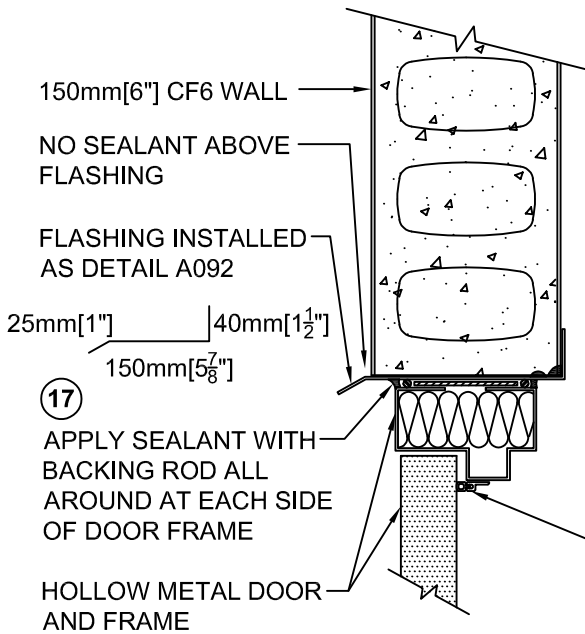

17

APPLY SEALANT WITH BACKING ROD ALL AROUND AT EACH SIDE OF DOOR FRAME

14

APPLY 6mm CORNER BEAD OF SEALANT AT TOP OF STARTER TO FLASHING AT HEADER OF OPENING.

OPENING

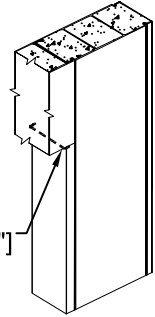

WEATHERSTRIP

JAMB SECTION

UNCORED CONFORM STARTER INSTALLED AS DETAIL A090

15

INSTALL SHIMS TO CENTRE DOOR FRAME IN ROUGH OPENING

16

FASTEN FRAME WITH FLATHEAD EXPANSION ANCHOR BOLTS.

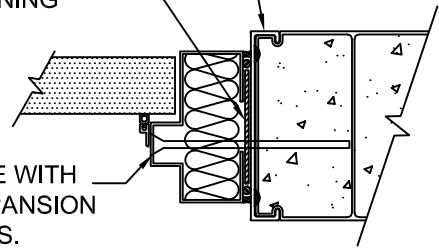

SILL SECTION

ROUGH OPENING

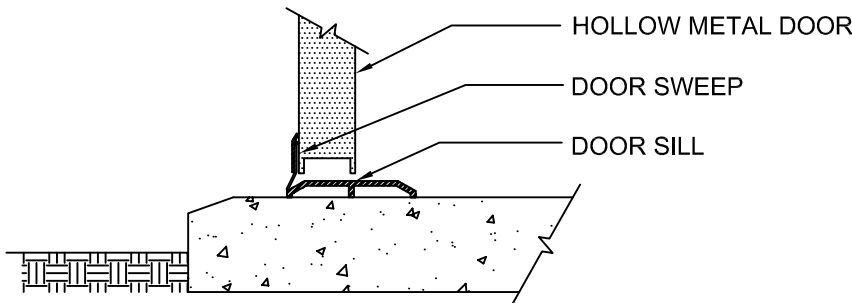

- DETAIL FOR FORMWORK ONLY
 - ALL DETAILS, REINFORCING STEEL & CONCRETE MUST BE DESIGNED & CONFIRMED BY PROJECT STRUCTURAL ENGINEER AND / OR PROJECT ARCHITECT.



Nuform Building Technologies Inc.
 100 Galcat Drive, Unit #2,
 Woodbridge, Ontario, Canada L4L 0B9
 Tel: 905-652-0001 Fax: 905-652-0002
 Toll Free: 1-877-747-9255
 Web Page: www.nuformdirect.com

**150mm[6"] CF6 WALL -
 HOLLOW METAL DOOR
 EXTERIOR**



DRAWING NO.	
A122	
COPYRIGHT 2024	
SCALE:	REVISION No.:
	R00