

Nuform Building Technologies Inc.



The RELINE™ panel provides a 12" wide finished face, interlocking joints and is installed lengthwise, with connection to supports at 24" maximum. Trim accessories are available for perimeter conditions, edges of openings and panel joints.

Profiles

RELINE™ Panel (12" x 3/8") (GEL1PLAA)

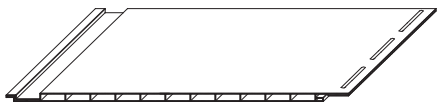

Corner Trim
(2 1/2" x 2 1/2")
(GEL1CNAA)

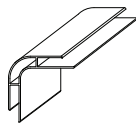

F-Trim (2 1/4" x 3")
(GEL1TFAA)

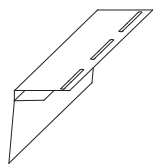

H-Trim (4" x 3/8")
(GEL1THAA)

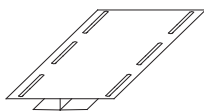

J-Trim (2 1/4" x 3/8")
(GEL1TJAA)

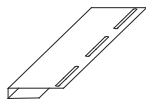

Tools

- Ladders and/or scaffolding
- Work table
- Hammer
- Chalkline
- Utility knife
- Caulking gun
- Sliding radial arm saw*
- Tape measure
- Square
- Level
- Tin snips
- Putty knife

* Use a fine tooth blade (12 or 16 teeth per inch) with the blade installed in the reverse direction. Some applicators prefer hand-held circular saws with a similar blade installation.

Preparation

1. Inspect and plan the job in advance. Check surfaces for straightness and install furring where necessary. Surfaces should be uniform and straight from various viewing angles.
2. If the RELINE™ panels run parallel to ceiling joists, roof trusses or wall studs, additional 1" x 3" wood nailing strips or strapping will have to be installed. Install these nailing strips perpendicular to the framing members, placing a strip every 16" to 24" maximum.
3. Install nailing strips or wood supports at the perimeter for connection of the F-Trim.
4. Install wood blocking at location of butt joints for support of the H-Trim.
5. Install wood blocking around all openings for support of the J-Trim.
6. When planning to suspend lighting or other items, install adequate backing at each location as required.
7. Prior to start of installation, provide a sealed vapor barrier such as 6 mil polyethylene, when necessary.

FOLLOW THE RECOMMENDED NAILING AND INSTALLATION PROCEDURES. IMPROPER INSTALLATION MAY CAUSE BUCKLING AND PERMANENT DAMAGE.

Fasteners

1. Use only corrosion-resistant nails (aluminum nails, stainless steel or galvanized roofing nails) with a minimum head diameter of $\frac{3}{8}$ ". The nail size should be $1\frac{1}{2}$ " for 1" penetration into the supports.

Basic Rules

1. All panels should slide free, after nailing, to allow for expansion and contraction. Allow a minimum of $\frac{1}{16}$ " (about the thickness of a dime) between the back of the nail head and the nailing strip.

****WARNING: Do not nail tightly. Doing so will cause the RELINE™ panel to be permanently damaged.**

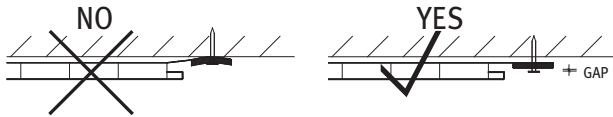

Figure 1

2. Nails should penetrate a minimum of 1" into a solid nailable surface, be no more than 24" apart and at least 4" from the end of the panel.

3. Always nail in the center of the slots. If you must nail near the end of a slot to hit a furring strip, extend the length of the slot with a nail slot-punch tool or router.

****WARNING: Do not nail at the end of a slot. Doing so will cause the RELINE™ panel to be permanently damaged.**

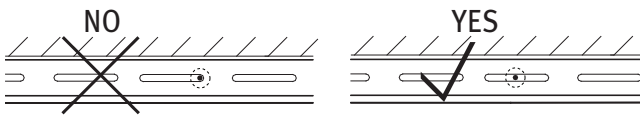

Figure 2

4. DO NOT FACE NAIL. RELINE™ panels expand and contract with temperature changes.

****WARNING: Face nailing can cause ripples in the panel. Doing so will cause the RELINE™ panel to be permanently damaged.**

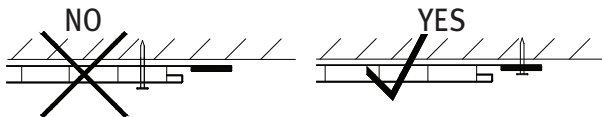

Figure 3

5. Leave a minimum of $\frac{1}{4}$ " clearance at ends of all panels and trims to allow for expansion and contraction.

****WARNING: No clearance at ends of panels can cause ripples in the panel. Doing so will cause the RELINE™ panel to be permanently damaged.**

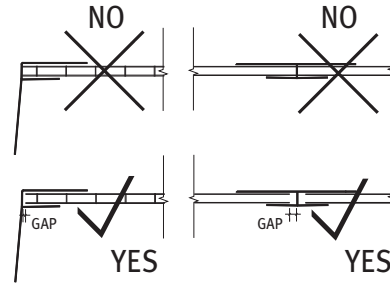

Figure 4

6. Install panels into interlocking joint at 30 to 45 degrees and rotate upward while pushing panel into the joint.

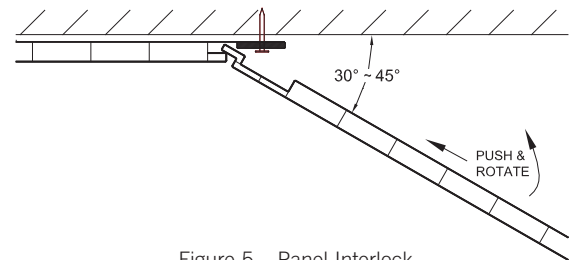

Figure 5 – Panel Interlock

7. Install panels with a slight gap ($\frac{1}{32}$ ") at the interlocking joint to allow for expansion and contraction. Use the blade of a putty knife to set the width of the joint.

****WARNING: Do not nail with tight joints in cold weather or cooler than normal ambient temperatures! Doing so will cause the RELINE™ panel to be permanently damaged.**

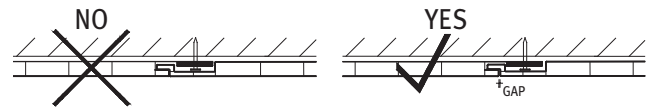

Figure 6

8. Before nailing, double-check to make certain that the panel is interlocked along its entire length. Keep the joints uniform to ensure that all joints remain parallel. Also make certain that the panel can slide freely, nail properly by starting at the center of the panel and working outwards.

9. Overlap joints in F-Trim, H-Trim and J-Trim components. Overlap joints $\frac{1}{2}$ " minimum. To do this, cut and remove a 1" section from the nailing face and also from the web of the trim. Overlap and leave $\frac{1}{4}$ " minimum for expansion and contraction at the nailing face. Use butt joints for Corner Trim leaving $\frac{1}{4}$ " gap and fill with sealant.

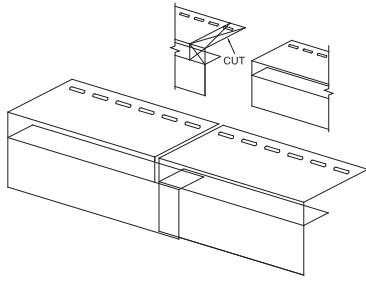

Figure 7 – F-Trim Overlap

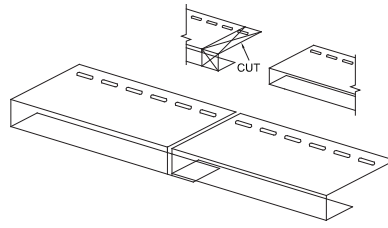

Figure 8 – J-Trim Overlap

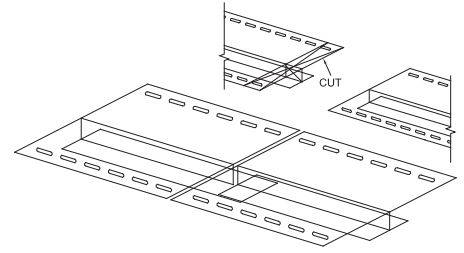

Figure 9 – H-Trim Overlap

10. Use a one-part, neutral cure, oxime, silicone sealant to seal all corners, to seal around all fixtures and to repair small holes. The sealant color should be off-white to match the RELINE™ panel. Use sealant such as Tremsil 600 by Tremco, Dow 1199 by Dow Corning or Bondaflex Sil 200GPN by Bondaflex Technologies.
11. In extremely cold weather, move the saw through the material slowly to prevent chipping or cracking or take the material to a heated area.

Ceiling Installation

1. Plan the layout of the RELINE™ panels to achieve an even spacing and to align with the walls and other adjacent work. Determine panel layout and width of first panel so that the last panel in each course will be a minimum of 8" wide. This will allow the panel to be flexed so that it can be installed into the interlocking joint and the F-Trim or Corner Trim without face nailing.
2. Use a chalk line to establish a straight line across the ceiling for the end of the first course. Plan the layout of the H-Trim to achieve an even balance or to align with adjacent work.
3. Begin by installing F-Trim or Corner Trim on all four sides of the ceiling and nail them at 24" maximum, to wood strips or the ceiling members along the perimeter of the ceiling area. If nailing to a wall is necessary, provide slots for all nails using a nail hole slot punch or router.
4. At corners of F-Trim, cut and remove the nailing face to leave 1/4" for expansion. Overlap the bottom face.
5. Fasten outside Corner Trim at 24" o.c. as shown and notch back of panel to accommodate nail head. Fasten inside Corner Trim with silicone or screw thru face and cover holes with plugs. Mitre corners as required. Provide 1/4" clearance at ends and sides of panels.

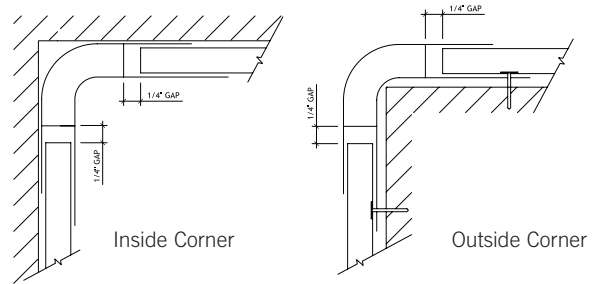

Figure 11 – Corner Trim

6. Cut the width and length of the first panel for the first course as per item 3. Install into the F-Trim or Corner Trim at one corner of the ceiling. Be sure to leave room for 1/8" expansion at panel sides and for 1/4" expansion at panel ends. Nail every 24" maximum, positioning nails in the center of the slots. Do not nail tightly. Do not nail within 4" of the end of the panels.

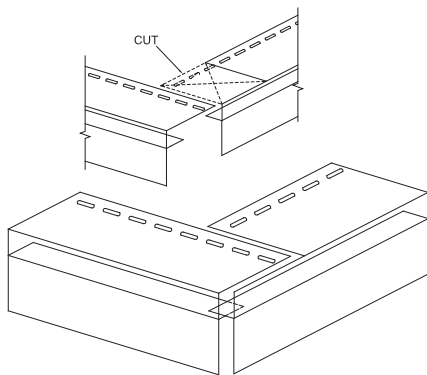

Figure 10 – F-Trim Corner

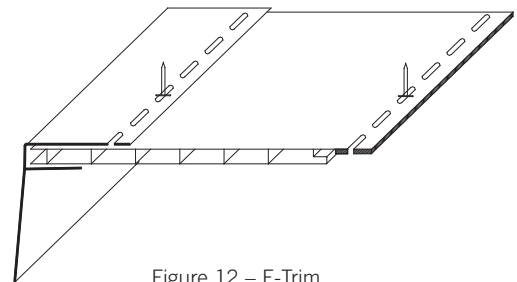

Figure 12 – F-Trim

7. Install the remaining panels in the first course across the ceiling. When cutting the last panel of the first course, make sure to allow room for 1/8" expansion at the side.

- Install H-Trim on the end of the first course leaving room for expansion $\frac{1}{4}$ ". Nail the H-Trim on the other side to wood supports at 24" on center.

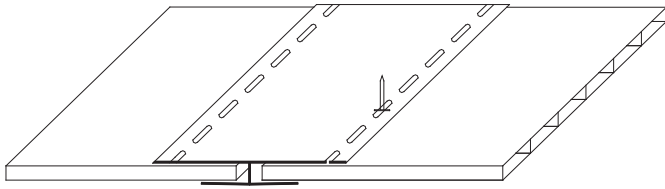

Figure 13 – H-Trim

- Continue with consecutive courses in a similar manner. Be sure to leave room for $\frac{1}{4}$ " expansion at each end of all panels, in all H-Trim. To assure best appearance, monitor the joints to ensure that the panels are aligned and remain parallel.

- As the installation proceeds, provide J-Trim around all openings. At the openings, cut the panels to suit the J-Trim. Be sure to leave room for expansion of the panel in the J-Trim, $\frac{1}{8}$ " for the sides parallel to a panel and $\frac{1}{4}$ " for the sides perpendicular to the panel.

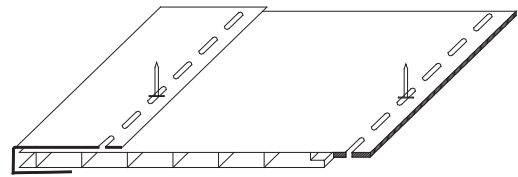

Figure 14 – J-Trim

- For the last course, cut the length of the panels to fit. Be sure to leave room for expansion in the F-Trim or Corner Trim. ($\frac{1}{4}$ " minimum)

Wall Installation

- Install RELINE™ panels vertically on walls in a similar manner to the ceiling installation.
- For RELINE™ panels on walls and ceilings, install the ceiling panels first, with the F-Trim or Corner Trim. Install the wall panels over the F-Trim.
- Connect RELINE™ panels to existing masonry walls using galvanized concrete screws (e.g. Tapcon – $\frac{3}{16}$ " x $1\frac{1}{4}$ ") or provide horizontal wood strapping at 2'-0" on center.
- Begin by installing J-Trim along the bottom of the wall. Drill $\frac{1}{4}$ " dia. drain holes in the bottom of the J-Trim at 16" on center.
- At corners, install Corner Trim vertically.
- Install J-Trim at top of wall if top of panels are not hidden behind other ceiling finish or installed into Corner Trim.
- Cut panels to allow at least $\frac{3}{8}$ ", for expansion and contraction, at the top of the panel.
- Install panels in bottom J-Trim and nail near the bottom of the panel, in the top of one slot to support the weight of the panel. Nail all other panels in the middle of the slot to allow for expansion and contraction.

Cleaning

- To remove common dirt and grime and maintain the appearance of RELINE™, wash using a general cleaner, applied with a sponge or soft bristle brush. The recommended cleaner is REVIVE cleaner, available from Nuform Building Technologies Inc.
 - For localized areas with heavy stains, wipe clean with Nuform Graffiti Remover, available from Nuform Building Technologies Inc.
 - Protect eyes and skin from direct contact with cleaning agents.
- **WARNING: Follow the precautionary labeling instructions on all cleaning agent containers.**
- Some cleaners may damage the finish of RELINE™ and must be tested on a small sample area first. Some of the non-recommended cleaners are Clorox, Pine Power, Tide Power, Grease Relief and Nail Polish Remover.
 - For removal of stubborn stains and other marks, contact your nearest Nuform representative for recommendations.

PURCHASER IS SOLELY RESPONSIBLE FOR DETERMINING THE SUITABILITY FOR USE OR APPLICATION OF ANY GOODS, INCLUDING COMPONENTS THEREOF, OR WHETHER SUCH GOODS MEET REQUIREMENTS OF APPLICABLE BUILDING CODES OR SAFETY CODES FOR SPECIFIC APPLICATIONS.



Nuform Building Technologies Inc.

1 Regalcrest Court
Woodbridge, Ontario, Canada
L4L 8P3
Toll Free: 1 877 747-WALL (9255)
Tel.: 905 652-0001 Fax: 905 652-0002

www.nuformdirect.com