

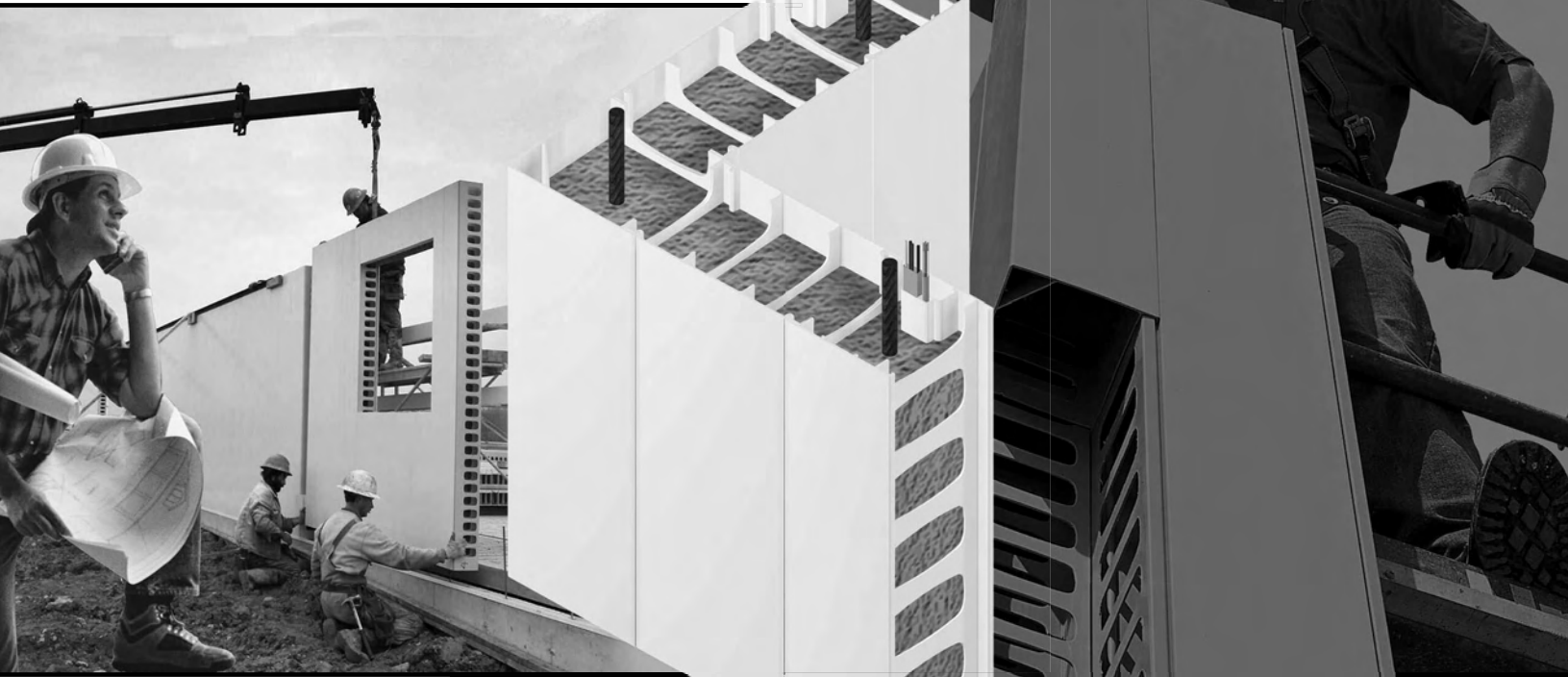

The Revolutionary Stay-in-Place
Concrete Wall Formwork

Engineering Guide



Version 1.0



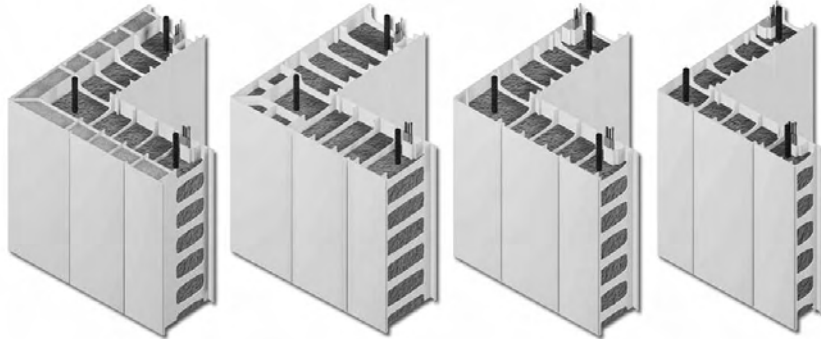

Building Solutions for a Better World...

Welcome to the world of Nuform Building Technologies Inc., an innovative quality-driven building technologies company. Since the introduction of Conform (formerly Royal Building Systems) in 1992, the product has received global recognition for its approach in providing an innovative solution to the construction industry.

Conform is a patented polymer-based stay-in-place formwork for concrete walls. The extruded components slide and interconnect together to create a concrete formwork. The result is permanent, attractive, and pre-finished concrete walls that can be easily constructed in any climate.

Conform provides flexibility of design, whether you are building a home or a large industrial complex.

The polymer components of Conform will not decay or deteriorate over a lifespan that can be measured in decades. Conform requires no painting, and resists ultraviolet radiation. Furthermore, Conform is highly durable, virtually maintenance free, impervious to weather, and extremely energy efficient.

Conform is also environmentally friendly as the polymer components are recyclable, energy efficient, and non-toxic.

Put it all together, and you can see that Conform offers complete design flexibility and an innovative building product that is easy to maintain, friendly to the environment, and built to last. Whether you are a developer, contractor, architect, engineer, or designer you can find attractive and cost effective solutions for your next project with Conform.

Contents

1. Introduction	1
2. Conform	2
2.1 General	2
2.2 Materials	4
3. Properties of Walls with Conform	7
3.0 Notation	7
3.1 General	7
4. Building Code Requirements for Walls	12
4.1 Use and Occupancy Requirements	12
4.2 Wall Finish Requirements	12
4.3 Structural Requirements	12
5. Structural Design of Concrete Walls	14
5.0 Notation	14
5.1 General	14
5.2 Design for Axial Loads and Flexure	15
5.3 Design for Shear	17
5.4 Walls Designed as Plain Concrete	18
5.5 Fasteners for Walls with Conform	23
6. Temporary Construction Conditions for Conform	24
6.0 Notation	24
6.1 General	24
6.2 Hydraulic Concrete Pressure	24
6.3 Lateral Wall Loads	25
6.4 Temporary Bracing	26
7. Illustrative Examples of Walls with Conform	28
7.1 Example #1 – CF8i Non-Bearing Wall (8300 mm)	28
7.2 Example #2 – CF8i Construction Conditions (8300 mm)	32
7.3 Example #3 – CF8i Foundation Wall (8' – 1")	34
References	37
Appendix A	38
Appendix B	39

1. Introduction

This Engineering Guide has been prepared by Nuform Building Technologies Inc. (Nuform) to assist engineers and architects in understanding the engineering design procedures for walls constructed using Conform. It is a part of our continuing effort to provide current and practical information to users of Conform.

The Engineering Guide provides information on the following aspects of walls using Conform components:

- Wall Materials
- Wall Properties
- Building Code Requirements for Walls
- Structural Design of Concrete Walls
- Temporary Construction Conditions

Also included in the guide are illustrative design examples of walls with Conform in various applications.

In addition to the Engineering Guide, the following guides are also available to assist in designing and building your projects using Conform.

- Technical Guide
- Design Guide
- Construction Guide
- Construction Guide For Non-Bearing Walls
- Finishing, Maintenance And Repair Guide

Although every effort has been made to ensure that all the information, provided in the Engineering Guide, is factual and that the numerical values are accurate and consistent with current engineering practice, Nuform does not assume any liability for errors or oversights resulting from the use of information contained in this guide. Anyone making use of the information provided in these guides assumes all liability arising from such use.

2. Conform

2.1 General

Conform consists of rigid polymer components that serve as permanent formwork for concrete walls including bearing walls, non-bearing walls, shear walls, retaining walls, foundation walls and many other types of walls. The extruded components slide and interlock together to create continuous formwork for monolithic concrete walls. The two faces of the wall formwork are connected together by continuous webs that create hollow rectangular components. The webs are punched with holes to allow the concrete to flow between the components. The hollow Conform components are erected and filled with concrete, in-situ, to provide a monolithic concrete wall. The Conform components remain in place after the concrete is placed and provide a durable polymer finish.

Concrete is placed with the Conform components in their final vertical position. This method of concrete wall construction is unique and allows slender concrete walls to be constructed in the vertical position. Typically, slender concrete walls are built using precast or tilt-up construction methods where the walls are cast in a horizontal position and then lifted into their final vertical position.

Conform provides permanent pre-finished formwork to create functional, economical concrete walls with many benefits. The Conform components are manufactured to suit the required wall heights and are site assembled or pre-assembled to suit any building configuration. Benefits of using Conform include speed of construction, flexibility of design, and overall economy of use.

There are four types of Conform as identified in Figure 2.1 and Table 2.1.

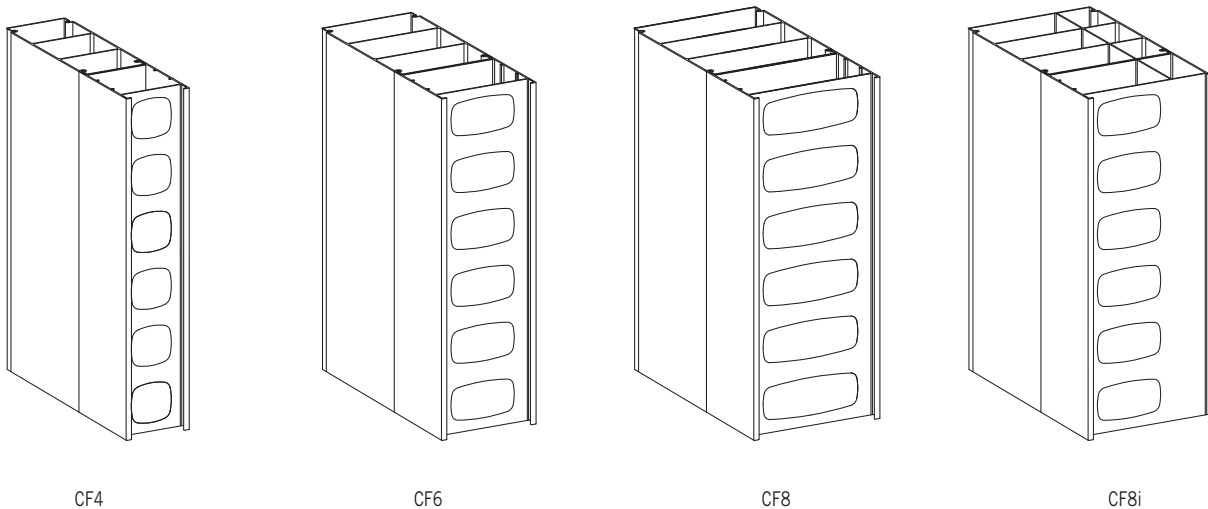

Fig. 2.1: Conform

Table 2.1: Conform Types

Conform	Wall Thickness			Concrete Quality	
	Overall (Nominal)	Concrete Core	Insulation ¹	Wall Area/m ³	Wall Area/yd ³
CF4	100 mm (4")	95 mm (3.74")	—	11.1 m ²	91 ft ²
CF6	150 mm (6")	145 mm (5.71")	—	7.2 m ²	59 ft ²
CF8	200 mm (8")	195 mm (7.68")	—	5.4 m ²	44 ft ²
CF8i	200 mm (8")	140 mm (5.47")	54 mm (2.13")	7.5 m ²	61 ft ²

Walls using Conform components are suitable for both conventional height concrete walls (unsupported length not greater than 25 times the wall thickness) and slender concrete walls (walls with unsupported lengths from 25 to 65 times the wall thickness). The walls can be designed to accommodate a wide range of axial, wind and seismic load conditions, using the equations that were developed for conventional and slender concrete walls. The equations are found in concrete design standards, concrete textbooks and concrete design handbooks for insulating concrete forms (ICF), precast and tilt-up wall construction.

The thickness of a wall with Conform is usually less than the thickness used for a conventionally formed wall in most applications. The slenderness of the wall is a major consideration in the design of the wall. The concrete design standards have specific sections that govern slender walls. The design of slender walls is based on a second-order analysis considering material non-linearity and cracking, as well as the effects of member curvature and lateral drift, duration of the loads, shrinkage and creep, and interaction with the supporting foundation.

¹ The CF8i components are pre-insulated with 54 mm (2.13') of polyurethane insulation. The insulation cavity is on the exterior side of the wall and is protected from the interior with the non-combustible concrete core.

2.2 Materials

Walls with Conform are comprised of three materials: concrete, Conform polymer components and steel reinforcing bars.

2.2.1 Concrete

Concrete comprises more than 90% (by mass and volume) of the walls. The architect or engineer shall specify the concrete mix required for each specific project.

Concrete mix recommended for the walls is a pump mix with a minimum 28-day concrete strength of either 20 MPa (3000 psi) or 25 MPa (3500 psi) for freeze-thaw conditions. The concrete strength is selected to suit the wall application and the applied loads. The maximum water to cement ratio is 0.55 to provide a high cement content for workability. The recommended coarse aggregate size is 10 mm (3/8") maximum and the recommended slump is 100 to 125 mm (4" to 5") at the point of discharge in order to suit the required workability of the concrete. Air entrainment is required when the concrete will be exposed to freeze thaw action.

Placement of concrete occurs directly from the top of the Conform components using a concrete pump and 3" discharge hose. The concrete is deposited cell by cell along the wall directly from the hose or with a hopper type chute in order to reduce the concrete spillage. Typically, the concrete will not flow along the wall more than 1.0 m (3') laterally, due to the webs of the components, regardless of the wall height. The height of the wall does not affect the placement methods since the small cells of the Conform components act as drop chutes (elephant trunk effect). The results of field tests indicate that the concrete can be dropped over 9 m (30') vertically without segregation, and there is no significant difference in aggregate gradation at the base of the wall compared to the top of the wall.⁽¹⁾

Consolidation of concrete in walls with Conform is achieved through the vibration of the components, which occurs during concrete placement and by manual methods. The results of field tests indicate that none or very little additional mechanical vibration is required depending on the concrete mix and method of placing. The vertical placement of the concrete, the use of a flowable pump mix and the action of the falling concrete on the webs all combine to create vibration that is sufficient to avoid honeycombing and entrapped air. At the top of walls and around embedded items, additional manual vibration is required using a rubber mallet to gently tap the forms. Internal mechanical vibrators are seldom used but small external vibrators are used on a very limited basis depending on the concrete mix, concrete placement method, quantity of reinforcing steel, embedded items and site conditions. Excessive vibration can lead to high hydrostatic pressures on the polymer components and may cause blowouts for high walls.

Curing of concrete in walls with Conform does not require any special consideration. The polymer encasement does not allow the concrete to dry prematurely. Samples taken from walls indicate excellent curing and only the top surface of the wall is exposed to potential drying.

(1) Trow Report No. BRBS-0006542-H, September 27, 2001

2.2.2 Polymer

The polymer is a rigid Polyvinyl Chloride (PVC) based composite material specifically developed to suit the co-extrusion process that is used in the manufacture of the hollow Conform components. Based on test results, the ultimate tensile strength of the polymer is 40.0 MPa (5750 psi) and the modulus of elasticity is 3200 MPa (0.464×10^6 psi).

The polymer components provide permanent formwork, exposure protection and pre-finished wall surfaces. The two faces of the components are held together by webs. The webs are cored at 83.3 mm (3.28") on center and the components are fabricated to align the coring between components. Approximately 50% of the concrete is monolithic at the webs and at the joints between components. Tests have shown that the confinement of the concrete by the polymer enhances the ductility of the wall under seismic conditions.

2.2.3 Steel Reinforcing Bars

Conventional deformed steel reinforcing bars are used for walls with Conform. The steel reinforcing bars are added when required for structural strength and deflection control of the concrete walls. Commonly, the steel reinforcing bars have a yield strength of 400 MPa (60,000 psi) and a modulus of elasticity of 200,000 MPa (29.0×10^6 psi).

Vertical bars in short walls are held in place by tying the bars to the foundation dowels and to the top webs of the Conform components. Vertical bars in tall slender walls are held in place by wire hoops that are tack welded or wire tied to the bars at 3 m (10') on center and fitted diagonally across the hollow cells of the Conform components. Vertical bars are spaced to suit the center of the cells in the box connector or panel components. Typically, this results in a bar spacing of 333 mm (13") or 500 mm (20") on center. (Refer to figure 2.2)

Horizontal bars in walls are placed through the coring in the webs of the Conform components. The horizontal bars, in lengths up to 5 m (16'), are placed as a wall is erected, and are lapped with adjacent bars. The horizontal bars are tied to the vertical bars or webs where possible. Horizontal bars are spaced to suit the coring in the webs of the Conform components. Typically, this results in a bar spacing of 250 mm (10"), 333 mm (13"), 417 mm (16") or 500 mm (20") on center. (Refer to figure 2.3)

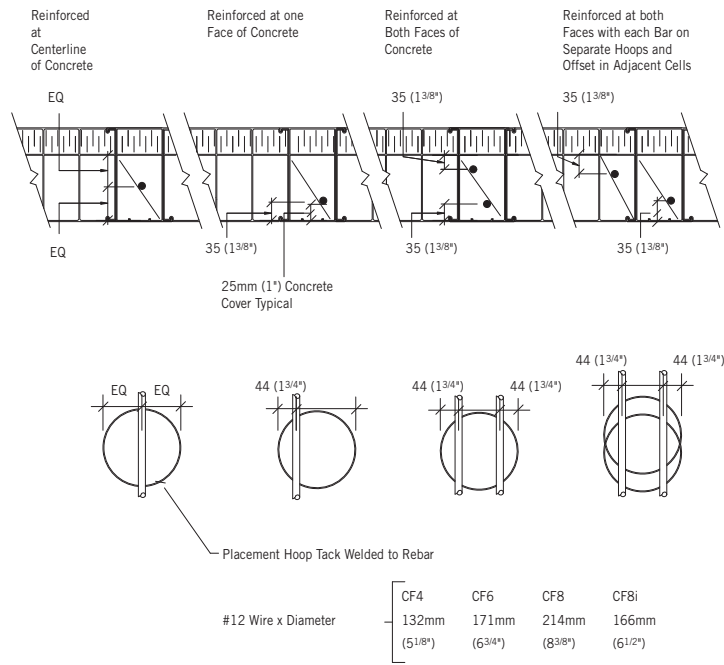

Fig. 2.2 Vertical Reinforcing Bars

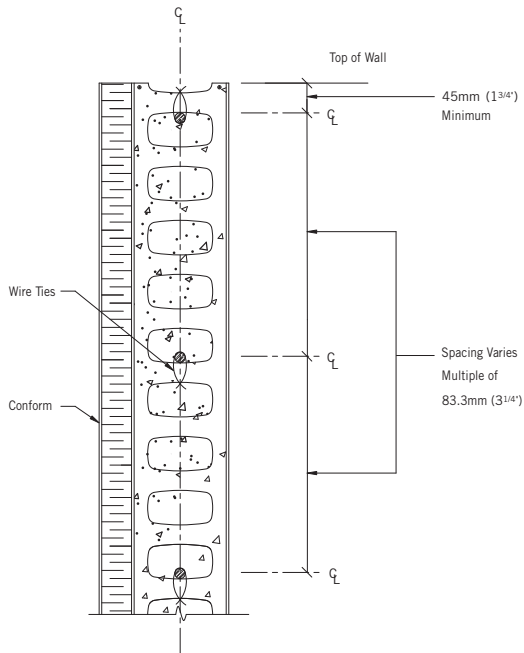

Fig. 2.3 Horizontal Reinforcing Bars

3. Properties of Walls with Conform

3.0 Notation

Imperial	Metric	Definition	Imperial	Metric	Definition
	A_c	= horizontal area of concrete section		I_c	= moment of inertia of concrete section
	$A_{c \text{ vert}}$	= area of concrete at web coring per unit height of wall		I_p	= moment of inertia of polymer section
	A_{coring}	= area of single core in polymer web		r_c	= radius of gyration of concrete section
	A_p	= area of polymer section		r_p	= radius of gyration of polymer section
	A_{wall}	= total area of wall		S_c	= section modulus of concrete section
	b_c	= design width of concrete section		S_p	= section modulus of polymer section
	b_p	= design width of polymer section		t_c	= thickness of concrete section
	b_{wall}	= total width of wall		t_p	= total thickness of polymer section
	b_{coring}	= width of coring in polymer web		t_{pf}	= thickness of polymer face
	h_{coring}	= height of coring in polymer web		t_{pw}	= design thickness of polymer web
				t_{wall}	= total thickness of wall
				W_{wall}	= total weight of wall

3.1 General

Conform is composed of box connector and panel components that interlock and are filled with concrete. The physical properties of walls with Conform are determined for the overall wall, the concrete placed in the wall and the polymer components.

- The physical properties of the polymer are based on a design face thickness of 2.54 mm (0.100") and a design web thickness of 1.83 mm (0.072"). The physical properties of the concrete are based on the total area less the area of polymer using a face thickness of 2.54 mm (0.100") and an average web thickness of 2.03 mm (0.080"). The change in the web thickness takes into accounts the web tolerances from extrusion and results in:

$$A_{\text{wall}} > A_p + A_c$$

- The design width of the concrete, b_c , equals the total concrete area divided by the concrete thickness.

$$b_c = \frac{A_c}{t_c}$$

- The radius of gyration, r , equals the square root of the moment of inertia divided by the area.

$$r = \sqrt{\frac{I}{A}}$$

The physical properties of walls with Conform in metric units and imperial units are given in Tables 3.1 to 3.4.

Table 3.1 Physical Properties of CF4 Walls

Properties	Metric Values		Imperial Values	
Overall Wall				
w_{wall}	-	2.28 kN/m ²	-	47.6 lb/ft ²
t_{wall}	-	100 mm	-	3.94 in
b_{wall}	-	1000 mm per metre	-	12.0 in per foot
A_{wall}	-	100000 mm ² per metre	-	47.24 in ² per foot
Polymer				
t_p	-	100.0 mm	-	3.94 in
b_p	-	1000 mm per metre	-	12.0 in per foot
t_{pf}	-	2.54 mm	-	0.100 in
t_{pw}	-	1.83 mm	-	0.072 in
A_p	-	7029 mm ² per metre	-	3.32 in ² per foot
S_p	-	311.2 10 ³ mm ³ per metre	-	5.79 in ³ per foot
I_p	-	15.56 10 ⁶ mm ⁴ per metre	-	11.39 in ⁴ per foot
r_p	-	47.05 mm	-	1.85 in
Concrete				
t_c	-	94.9 mm	-	3.74 in
b_c	-	951.8 mm per metre	-	11.42 in per foot
A_c	-	90322 mm ² per metre	-	42.67 in ² per foot
S_c	-	1428.9 10 ³ mm ³ per metre	-	26.58 in ³ per foot
I_c	-	67.82 10 ⁶ mm ⁴ per metre	-	49.66 in ⁴ per foot
r_c	-	27.40 mm	-	1.08 in
coring	-	12 cores per metre	-	3.66 cores per foot
h_{coring}	-	58.3 mm	-	2.30 in
b_{coring}	-	63.5 mm	-	2.50 in
A_{coring}	-	3299 mm ²	-	5.11 in ²
$A_{c\ vert}$	-	39588 mm ² per metre	-	18.70 in ² per foot

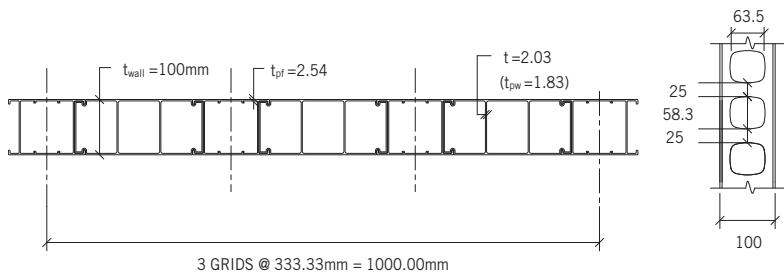

Fig. 3.1

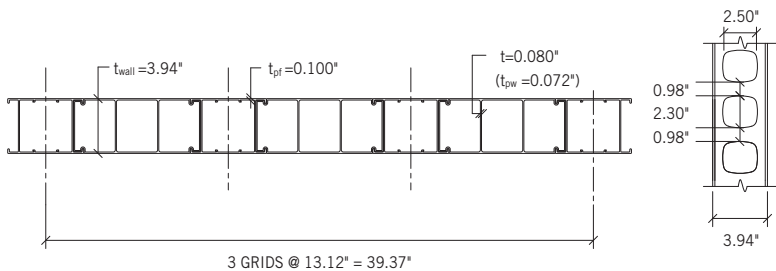

Fig. 3.1a

Table 3.2 Physical Properties of CF6 Walls

Properties	Metric Values		Imperial Values	
Overall Wall				
W_{wall}	-	3.45 kN/m ²	-	72.1 lb/ft ²
t_{wall}	-	150 mm	-	5.91 in
b_{wall}	-	1000 mm per metre	-	12.0 in per foot
A_{wall}	-	150000 mm ² per metre	-	70.87 in ² per foot
Polymer				
t_p	-	150.0 mm	-	5.91 in
b_p	-	1000 mm per metre	-	12.0 in per foot
t_{pf}	-	2.54 mm	-	0.100 in
t_{pw}	-	1.83 mm	-	0.072 in
A_p	-	7293 mm ² per metre	-	3.45 in ² per foot
S_p	-	497.7 10 ³ mm ³ per metre	-	9.26 in ³ per foot
I_p	-	37.33 10 ⁶ mm ⁴ per metre	-	27.34 in ⁴ per foot
r_p	-	71.54 mm	-	2.82 in
Concrete				
t_c	-	144.9 mm	-	5.71 in
b_c	-	955.8 mm per metre	-	11.47 in per foot
A_c	-	138498 mm ² per metre	-	65.43 in ² per foot
S_c	-	3345.2 10 ³ mm ³ per metre	-	62.22 in ³ per foot
I_c	-	242.39 10 ⁶ mm ⁴ per metre	-	177.50 in ⁴ per foot
r_c	-	41.84 mm	-	1.65 in
coring	-	12 cores per metre	-	3.66 cores per foot
h_{coring}	-	58.3 mm	-	2.30 in
b_{coring}	-	109.7 mm	-	4.32 in
A_{coring}	-	5847 mm ²	-	9.06 in ²
$A_c \text{ vert}$	-	70164 mm ² per metre	-	33.15 in ² per foot

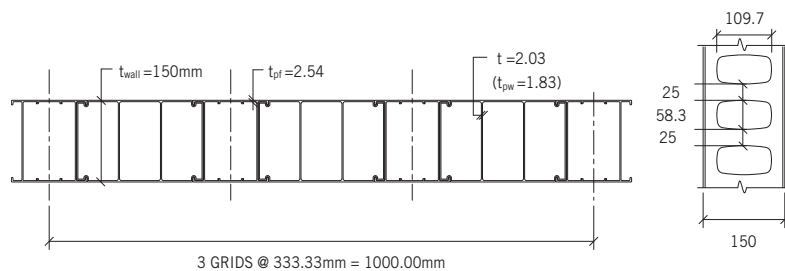

Fig. 3.2

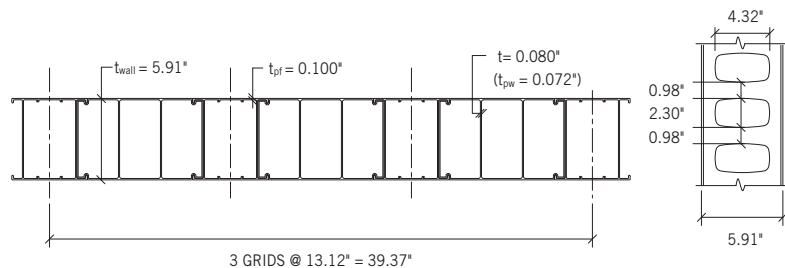

Fig. 3.2a

Table 3.3 Physical Properties of CF8 Walls

Properties	Metric Values		Imperial Values					
Overall Wall								
w_{wall}	-	4.62 kN/m ²	-	96.5 lb/ft ²				
t_{wall}	-	200 mm	-	7.87 in				
b_{wall}	-	1000 mm per metre	-	12.0 in per foot				
A_{wall}	-	200000 mm ² per metre	-	94.49 in ² per foot				
Polymer								
t_p	-	200.0 mm	-	7.87 in				
b_p	-	1000 mm per metre	-	12.0 in per foot				
t_{pf}	-	2.54 mm	-	0.100 in				
t_{pw}	-	1.83 mm	-	0.072 in				
A_p	-	7599 mm ² per metre	-	3.59 in ² per foot				
S_p	-	698.0 10 ³ mm ³ per metre	-	12.98 in ³ per foot				
I_p	-	69.80 10 ⁶ mm ⁴ per metre	-	51.11 in ⁴ per foot				
r_p	-	95.84 mm	-	3.77 in				
Concrete								
t_c	-	194.9 mm	-	7.67 in				
b_c	-	957.8 mm per metre	-	11.49 in per foot				
A_c	-	186686 mm ² per metre	-	88.20 in ² per foot				
S_c	-	6071.8 10 ³ mm ³ per metre	-	112.94 in ³ per foot				
I_c	-	591.76 10 ⁶ mm ⁴ per metre	-	433.34 in ⁴ per foot				
r_c	-	56.3 mm	-	2.22 in				
coring	-	12 cores per metre	-	3.66 cores per foot				
h_{coring}	-	58.3 mm	-	2.30 in				
b_{coring}	-	150.0 mm	- <tr <td>A_{coring}</td> <td>-</td> <td>8241 mm²</td> <td>-</td> <td>12.77 in²</td>	A_{coring}	-	8241 mm ²	-	12.77 in ²
$A_{c\ vert}$	-	98892 mm ² per metre	-	46.72 in ² per foot				

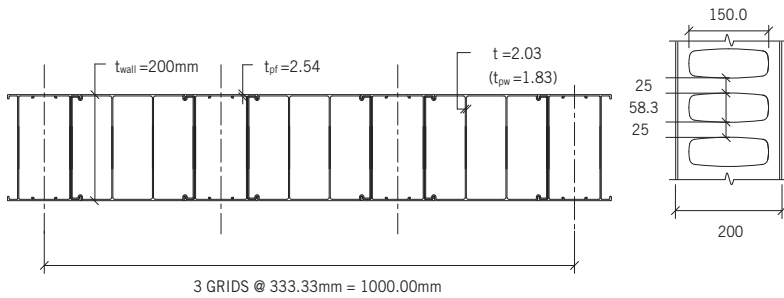

Fig. 3.3

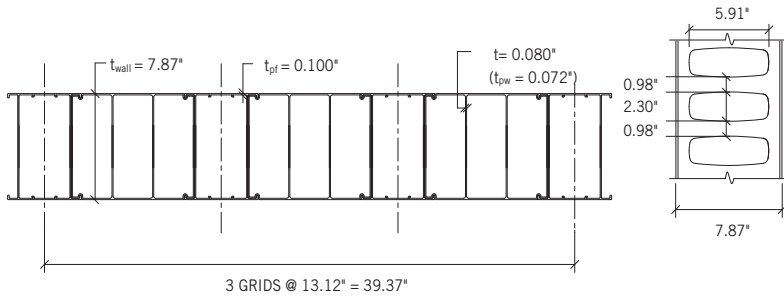

Fig. 3.3a

Table 3.4 Physical Properties of CF8i Walls

Properties	Metric Values		Imperial Values	
Overall Wall				
W_{wall}	-	3.41 kN/m ²	-	71.2 lb/ft ²
t_{wall}	-	200 mm	-	7.87 in
b_{wall}	-	1000 mm per metre	-	12.0 in per foot
A_{wall}	-	200000 mm ² per metre	-	94.49 in ² per foot
Polymer				
t_p	-	200 mm	-	7.87 in
b_p	-	1000 mm per metre	-	12.0 in per foot
t_{pf}	-	2.54 mm	-	0.100 in
t_{pw}	-	1.83 mm	-	0.072 in
A_p	-	10620 mm ² per metre	-	5.02 in ² per foot
$S_{p^{(1)}}$	-	628.2 10 ³ mm ³ per metre	-	11.68 in ³ per foot
I_p	-	73.29 10 ⁶ mm ⁴ per metre	-	53.67 in ⁴ per foot
r_p	-	83.08 mm	-	3.27 in
Concrete				
t_c	-	138.9 mm	-	5.47 in
b_c	-	961.7 mm per metre	-	11.54 in per foot
A_c	-	133577 mm ² per metre	-	63.11 in ² per foot
S_c	-	3092.5 10 ³ mm ³ per metre	-	57.52 in ³ per foot
I_c	-	214.79 10 ⁶ mm ⁴ per metre	-	157.29 in ⁴ per foot
r_c	-	40.10 mm	-	1.58 in
coring	-	12 cores per metre	-	3.66 cores per foot
h_{coring}	-	58.3 mm	-	2.30 in
b_{coring}	-	109.7 mm	-	4.32 in
A_{coring}	-	5847 mm ²	-	9.06 in ²
A_c vert	-	70164 mm ² per metre	-	33.15 in ² per foot

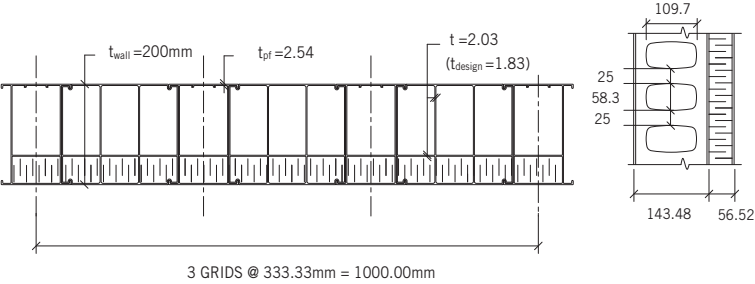

Fig. 3.4

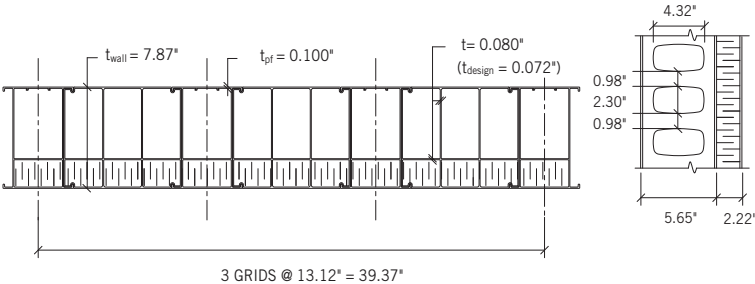

Fig. 3.4a

(1) Minimum value at non-foamed face.

4. Building Code Requirements for Walls

4.1 Use and Occupancy Requirements

The local building codes will specify buildings and construction materials to be combustible or non-combustible, and fire rated or non-fire rated, depending on the use and occupancy associated with each wall and each building. The walls with Conform are governed by the type of construction that is required to meet the fire performance specified by the building codes.

Walls using Conform components as a stay-in-place formwork can be used in all types of construction. The walls are designed as plain concrete walls or steel reinforced concrete walls in accordance with CSA A23.3 or ACI 318. The polymer is not a structural component. Refer to Table 4.6 of the Conform Technical Guide for the fire resistance of Conform Walls.

4.2 Wall Finish Requirements

The building codes specify requirements for wall cladding and wall finishes.

The polymer finished concrete wall has a flame spread rating of 25 or less and a smoke developed classification of 350 or less, using the ULC S102.2 Test Method and a flame spread rating of 25 or less and a smoke developed classification of 450 or less, using the ASTM E84 Test Method. The properties of the finished wall meet the code requirements of most interior finish applications and the Conform can be left exposed⁽¹⁾.

The polymer material is a combustible covering and is acceptable as an exposed exterior cladding for many applications. The polymer is not permitted as a finished covering where non-combustible cladding is specified by the building codes. In these cases the exterior surface of Conform must be covered with a non-combustible cladding. Typically, this occurs adjacent to property lines and depends on the building setback and the percentage of openings. It is necessary to consult the local building codes or local building officials to confirm the wall finish requirements for use, occupancy and setback.

4.3 Structural Requirements

The local building codes or design standards will specify the structural load conditions, load values and load combinations that must be considered in the design of walls. These loads are analyzed to determine the effects on the wall as illustrated in Figures 4.1 and 4.2

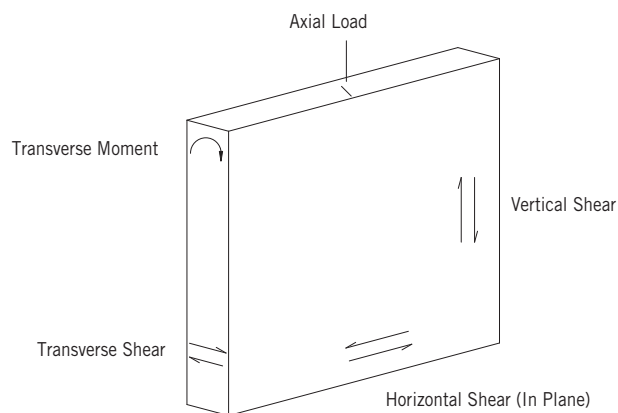

Fig.4.1: Wall Forces commonly analyzed for Walls

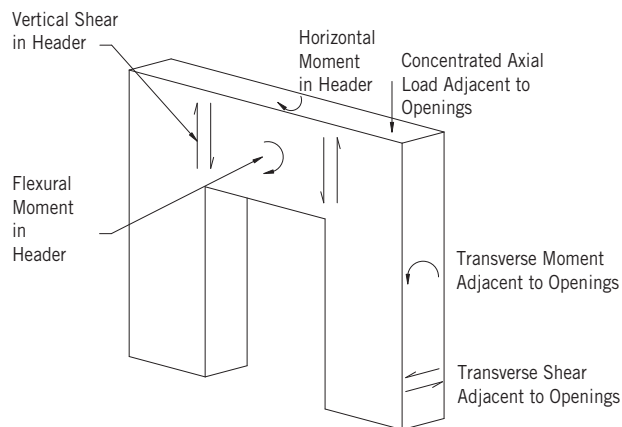

Fig. 4.2: Wall Forces commonly analyzed at Openings in Walls

(1) FLAME SPREAD AND SMOKE DEVELOPMENT RATINGS

The numerical flame spread and smoke development ratings set out herein are not intended to reflect hazards presented by any Nuform products, including the Conform concrete forming system, or any other material under actual fire conditions. These ratings are determined by small-scale tests conducted by independent testing facilities using the ASTM E-84 (American Society for Testing and Material) test standard. NUFORM BUILDING TECHNOLOGIES INC. PROVIDES THESE RATINGS FOR PRODUCT COMPARISON PURPOSES ONLY. Like other many building materials (e.g. wood), panels made of polyvinyl chloride (PVC) will burn. When ignited, PVC may produce dense smoke which may be toxic. Proper fire safety considerations require proper design of a facility and the fire suppressions systems used, as well as necessary precautions during construction and occupancy. Local codes, insurance requirements, and any special needs of the product user will determine the correct fire rated interior finish and fire suppressions system necessary for a specific installation.

4.3.1 Axial Loads

Axial loads include the superimposed dead load and live load from floors or roofs. Typically, the weight of wall above mid-span is applied as a concentrated axial load at the top of the wall. The self-weight of the wall is considered since it represents a significant contribution to the axial load and increases the P- Δ effect of slender walls.

4.3.2 Flexural Moments

Flexural moments are combined with axial loads in the design of the walls. Flexural moments may result from loads suspended from the face of the wall or from loads applied with an eccentricity at the top of the wall.

Lateral loads on walls result in a flexural moment and are caused by wind conditions or seismic conditions at a specific building location.

The wind load for a wall is specified as the algebraic sum of the external and internal pressures on the walls. The minimum recommended lateral load for exterior and interior walls is 0.50 kPa (10 psf).

The seismic load for walls is specified as a function of the seismic acceleration, the wall weight and other factors. It should be noted that the screws recommended as fasteners for non-bearing walls, provide a non-ductile connection which requires a higher seismic coefficient than ductile connections.

4.3.3 Shear Loads

For walls that are part of the primary structural system or main force resisting system, the wind loads and seismic loads are calculated in accordance with the local building codes and applicable standards.

The resulting shear forces are distributed to the walls based on the building configuration, wall stiffness and torsional effects.

4.3.4 Design Factors

The current structural design standards use factored loads and member resistance (reduced nominal strength) to determine the structural acceptability of members. In Canada, this is called Limit States Design (LSD) and in the USA, the Load and Resistance Factor Design (LRFD).

In Canada, the load factors are the same for all materials. The Canadian standards specify a factor of 1.25 or 0.85 for dead loads, 1.5 for live loads, 1.5 for wind loads and 1.0 for seismic loads. The resistance factor for concrete is 0.6 as specified in CSA A23.3.

In the USA, the load factors vary with the design standard for each specific material. Therefore it is suggested that the ASCE-7 Standard is the most appropriate, since it provides load factors applicable to all materials. The ASCE-7 standard specifies a factor of 1.2 or 0.9 for dead loads, 1.6 for live loads, 1.6 for wind loads and 1.0 for seismic loads. The resistance factor or strength reduction factor, specified for concrete, varies for different load effects, i.e. flexure, shear, etc. The strength reduction factors should be taken from ACI 318.

The design factors for concrete walls are summarized in Table 4.3.

Table 4.3 Design Factors

	Canada	USA
LOAD FACTORS		
Dead Load	1.25 or 0.85	1.2 or 0.9
Live Load	1.5	1.6
Wind Load	1.5	1.6
Seismic Load	1.0	1.0
CONCRETE RESISTANCE FACTORS		
Flexure	0.85	0.90
Compression	0.6	0.65
Shear	0.6	0.75
Plain concrete	0.6	0.55

5. Structural Design of Concrete Walls

5.0 Notation

Imperial	Metric	Definition	Imperial	Metric	Definition
	A_c	= horizontal area of concrete section	(ϕM_n)	M_r	= factored moment resistance
	$A_{c\text{ vert}}$	= area of concrete at web coring		M_{rc}	= factored moment resistance of concrete
(A_{vf})	A_s	= area of steel reinforcing bars	(P_u)	P_f	= factored axial load
	d	= depth of member	(ϕP_n)	P_r	= factored axial load resistance
	e	= eccentricity of axial load measured from center at member		Q	= first moment of inertia of wall at outer most vertical joint
	E_c	= modulus of elasticity of concrete		r	= radius of gyration mm (in)
	El_c	= stiffness of concrete section	(h)	t	= thickness of member mm (in)
	f'_c	= specified compressive strength of concrete at 28 days		t_c	= thickness of concrete section
	f_y	= yield strength of steel reinforcement		v_f	= longitudinal shear stress
	I	= moment of inertia	(ϕV_n)	V_f	= factored shear
	I_c	= moment of inertia of concrete section		V_r	= factored shear resistance
	k	= effective length factor		$V_{rh/c}$	= horizontal factored shear resistance of plain concrete
(l_c)	l_u	= vertical clear distance between supports mm (in)		$V_{rv/c}$	= vertical factored shear resistance of plain concrete
	L	= vertical design span of wall		μ	= coefficient of friction
	M_{cr}	= cracking moment	(ϕ)	ϕ_c	= resistance factor for concrete

5.1 General

The structural design of concrete walls must be performed in conformance with local building codes and the applicable concrete design standard. In Canada, the applicable design standard is CSA Standard A23.3, Design of Concrete Structures and in the USA, the applicable design standard is ACI 318, Building Code Requirements for Reinforced Concrete.

Both of these standards use factored loads and member resistance for the design of concrete walls. In Canada, this is called Limit States Design (LSD) and in the USA, Load Resistance Factor Design (LRFD). The two standards have minor variations in the resistance factors and load factors but the designs by both standards are essentially identical. The strength values noted in this guide are resistance strength values that are evaluated against the effects of factored loads. Refer to Section 4.3.4 for a discussion of the load and resistance factors.

The design procedures for walls that consider the Conform components as a formwork only, are documented in the concrete standards and in concrete design handbooks. The design requirements and equations are readily available from the CSA and ACI standards as well as from handbooks and textbooks for Precast Concrete, Insulating Concrete Forms and Tilt-Up Concrete Construction. Due to the polymer components, the design procedures for vertical shear must take into account the reduced concrete area at the joints between the components, i.e. at the coring in the webs of the components.

5.2 Design for Axial Loads and Flexure

The concrete design standards include sections that deal with the design of concrete walls subject to axial loads with and without flexure. The combined effects of axial load, flexural moment and additional P- Δ effects govern the wall design. Walls must have a slenderness ratio not greater than 200 ($kl_u/r \leq 200$ or $l_u/t \leq 65$).

The standards state that members require a detailed analysis of the factored forces and moments using a second order analysis that considers material non-linearity and cracking, as well as the effects of member curvature, lateral drift, duration of the loads, shrinkage, creep and the interaction with the supporting foundation. Refer to CSA A23.3, section 10.13 and ACI 318, section 10.10.

The design is based on strain compatibility and equilibrium using material resistance factors and material properties. The design method using a second order analysis is applicable to all walls under all load conditions. However, the concrete design standards also include some simplified design methods that are conservative approximations compared to the second order analysis method. The simplified methods are subject to limitations as outlined in the standards. The simplified design methods are summarized in Figure 5.1 and Figure 5.2. The simplified design methods are outlined briefly below but the reader should refer to the appropriate concrete design standard for a complete discussion of the methods.

5.2.1 Plain Concrete Walls

An Empirical Design Method is given for axial load capacity. The wall capacity is governed by compression stresses since the concrete is not in tension. This method is limited to walls with a slenderness ratio not greater than 60 ($kl_u/r \leq 60$ or $l_u/t \leq 20$) and with the resultant of all factored loads within the middle third of the total wall thickness, ($e \leq t/6$). The minimum thickness is 190 mm (7 1/2") for foundation walls, firewalls, party walls, and exterior basement walls. Refer to CSA A23.3, section 22.4.1.3 or ACI 318, section 22.6.

5.2.2 Plain Concrete Walls

A Strength Design Method is given for axial and flexural load capacity. The wall capacity is governed by the compression and tension stresses, to ensure that the concrete remains uncracked. This method is limited to walls with a slenderness ratio not greater than 60 ($kl_u/r \leq 60$ or $l_u/t \leq 20$) and the resultant of all factored loads outside the middle third of the total wall thickness, ($e > t/6$). The minimum eccentricity is 0.10t. Refer to CSA A23.3, sections 22.4.1.2 or ACI 318, section 22.5.

5.2.3 Steel Reinforced Concrete Walls

An Empirical Design Method is given for axial load capacity. The wall capacity is governed by the compression stresses since the concrete is not in tension. For bearing walls, this method is limited to walls with slenderness not greater than 75 ($kl_u/r \leq 75$ or $l_u/t \leq 25$) and the resultant of all factored loads within the middle third of the total wall thickness, ($e \leq t/6$). The minimum thickness is 190 mm (7 1/2") for walls that retain earth and foundation walls, 150 mm (6") for cast in situ walls and 100 mm (4") for precast or tilt-up walls. For nonbearing walls, this method is limited to walls with a slenderness ratio not greater than 100 ($kl_u/r \leq 100$ or $l_u/t \leq 30$) and a minimum thickness of 100 mm (4"). Refer to CSA A23.3, section 14.5 or to ACI 318, section 14.5.

5.2.4 Steel Reinforced Concrete Walls

A Moment Magnification Method is given for combined axial and flexural load capacity. The combined axial and flexural compressive stress in the concrete and the tensile stress in the steel reinforcing bars govern the wall capacity. A magnifier to account for slenderness effects is used to increase the flexural moment. This method is limited to walls with slenderness not greater than 100 ($kl_u/r \leq 100$ or $l_u/t \leq 30$). Refer to CSA A23.3, sections 10.14 and 10.15 or ACI 318, sections 10.11 and 10.12.

5.2.5 Steel Reinforced Concrete Walls

A Moment Magnification Method is given for flexural load capacity when the axial loads are not significant. The factored axial stress shall be less than $0.09\phi_c f'_c$, for CSA A23.3 and less than $0.06 f'_c$, for ACI 318. This ensures that the flexural compression stresses in the concrete and the flexural tension stresses in the steel reinforcing bars govern the wall capacity. A magnifier to account for slenderness effects is used to increase the flexural moment. For walls with one mat of reinforcement, this method is limited to walls with slenderness not greater than 150 ($kl_u/r \leq 150$ or $l_u/t \leq 50$). For walls with a mat of reinforcement near each face, this method is limited to walls with slenderness not greater than 200 ($kl_u/r \leq 200$ or $l_u/t \leq 65$). The minimum thickness is 140mm (5 1/2") for walls without stiffening elements. Refer to CSA A23.3, clause 23.4.1 or to ACI 318, clause 14.8.

The selection of the applicable design method for a given wall is at the discretion of the professional engineer responsible for the structural integrity of the structure. The selection should be based on the specific project requirements, the applicable building codes and standards and an analysis of the wall to determine the mode of behaviour.

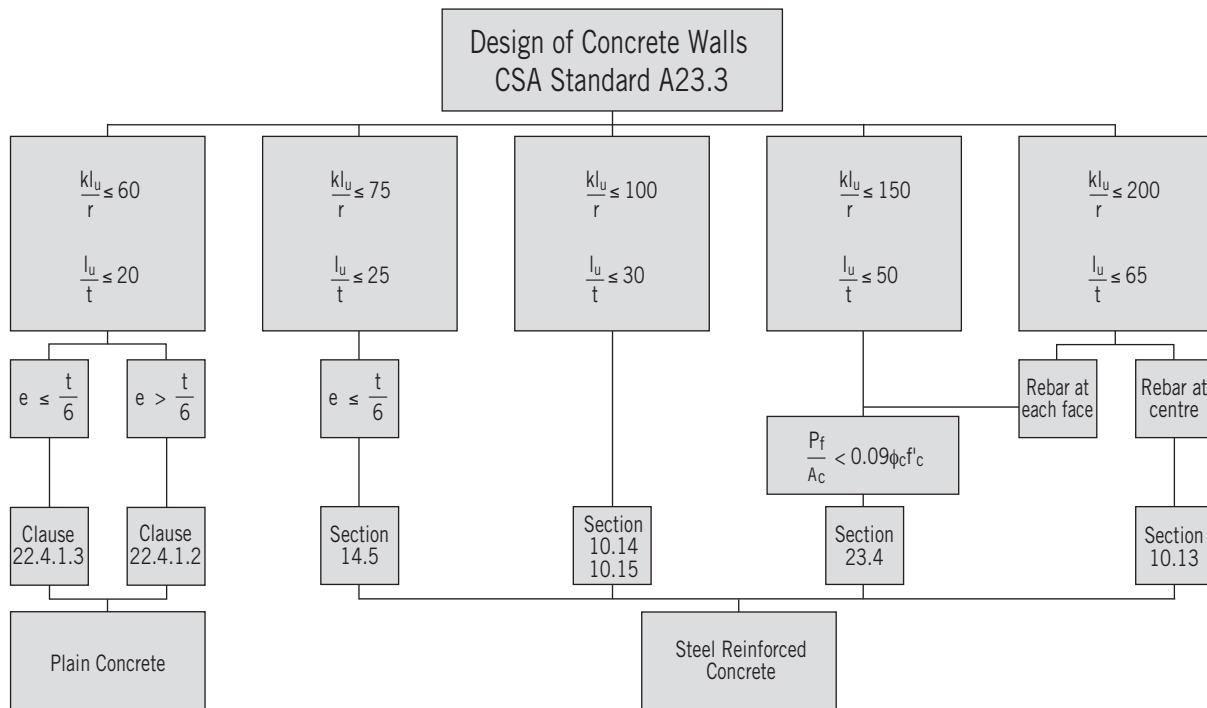

Fig. 5.1

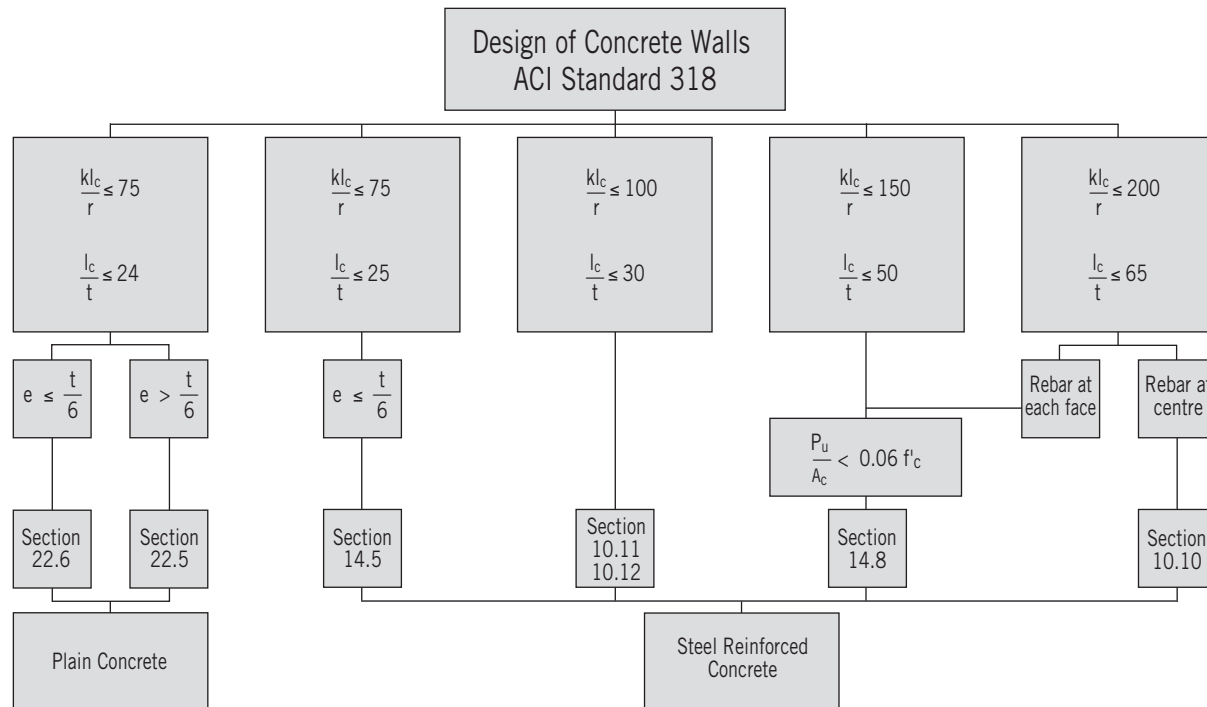

Fig. 5.2

5.3 Design for Shear Forces

Shear forces can occur in three directions in concrete walls; transverse, horizontal and vertical. Refer to Figures 4.1 and 4.2

The shear design of concrete is specified in the CSA A23.3 and ACI 318 concrete design standards. The use of Conform polymer components for the formwork of concrete walls has a negligible effect on the transverse and horizontal shear design. However, the vertical shear design is affected by the polymer webs since the concrete is monolithic only at the coring.

5.3.1 Transverse Shear and Horizontal Shear

For walls designed as plain concrete the following equations are provided for transverse and horizontal shear capacity, ignoring axial loads .

$$V_r = \frac{2}{3} (0.2 \phi_c \sqrt{f'_c} A_c) \quad (\text{CSA A23.3 Eq. 22-3})$$

where $\phi_c = 0.60$

$$\phi V_n = \phi \frac{4}{3} \sqrt{f'_c} A_c \quad (\text{ACI 318 Eq. 22-8})$$

where $\phi = 0.55$

For walls designed as steel reinforced concrete the following are provided for transverse and horizontal shear capacity, ignoring axial loads and shear reinforcement.

$$V_r = 0.2 \phi_c \sqrt{f'_c} A_c \quad (\text{CSA A23.3 Eq. 11-6})$$

where $\phi_c = 0.60$

$$\phi V_n = \phi 2 \sqrt{f'_c} A_c \quad (\text{ACI 318 Eq. 11-3})$$

where $\phi = 0.75$

5.3.2 Transverse and Horizontal Shear at Construction Joints

At the base of walls or horizontal construction joints between wall sections, the transverse and horizontal shear is limited by the shear friction reinforcement. Ignoring cohesion and axial loads the following is suggested for the factored shear resistance.

$$V_r = \phi_c A_s f_y \mu \quad (\text{CSA A23.3 Eq. 11-32})$$

where $\phi_c = 0.60$
 $\mu = 0.60$

$$\phi V_n = \phi A_{vf} f_y \mu \quad (\text{ACI 318 Eq. 11-25})$$

where $\phi = 0.75$
 $\mu = 0.60$

5.3.3 Vertical Shear in Flexural Members

Vertical shear occurs in wall header that spans horizontally between supports over an opening, as shown in Figure 4.2. Horizontal reinforcing bars are required for flexure and the diagonal shear capacity as determined by current standards for reinforced concrete of constant thickness.

$$V_r = 0.2 \phi_c \sqrt{f'_c} t_c d \quad (\text{CSA A23.3 Eq. 11-6})$$

where $\phi_c = 0.60$

$$\phi V_n = \phi 2 \sqrt{f'_c} t_c d \quad (\text{ACI 318 Eq. 11-3})$$

where $\phi = 0.75$

However, for headers constructed using the Conform components, it must be assumed that a vertical crack due to shrinkage or temperature effects may occur at the joints between the Conform components. Therefore, vertical shear friction reinforcement, in addition to flexural reinforcement is required horizontally across each vertical shear plane or joint between components.

The shear reinforcement can be calculated using the area of horizontal reinforcement and a concrete area equal to 80% of the coring area, which will allow for a 10 mm (3/8") misalignment of the cores. Refer to Section 11.6 of CSA A23.3 or section 11.7 of ACI 318 or use the simplified equations given in 5.3.2 above, for shear friction reinforcement only.

$$V_r = \phi_c A_s f_y \mu \quad (\text{CSA A23.3 Eq. 11-32})$$

where $\phi_c = 0.60$
 $\mu = 1.40$

$$\phi V_n = \phi A_{vf} f_y \mu \quad (\text{ACI 318 Eq. 11-25})$$

where $\phi = 0.75$
 $\mu = 1.40$

It should be noted that the shear resistance is limited by a maximum shear stress such that

$$V_r \leq 0.25 \phi_c f'_c (0.80 A_{c \text{ vert}}) \quad (\text{CSA A23.3 cl 11.6.1})$$

and $\leq 7.0 \phi_c (0.80 A_{c \text{ vert}})$
where $\phi_c = 0.60$

$$\phi V_n \leq \phi 0.2 f'_c (0.80 A_{c \text{ vert}}) \quad (\text{ACI 318 cl 11.7.5})$$

and $\leq \phi 800 (0.80 A_{c \text{ vert}})$
where $\phi = 0.75$

5.3.4 Vertical Shear in Shear Walls

For a wall subjected to horizontal shear forces, as shown in Figure 4.2, vertical bars are required for flexure and the diagonal shear capacity is determined in accordance with the concrete standards for plain and reinforced concrete.

However the reduced concrete area of the coring at joints between components will determine the vertical shear or longitudinal shear capacity of the wall.

The maximum factored vertical shear is based on the maximum vertical tension from dowels or longitudinal bars or based on the maximum longitudinal shear force at the centroid of the wall where

$$V_f(\text{vert}) = \frac{V_f(\text{horiz}) Q}{I_c}$$

$$V_f(\text{vert}) = V_f(\text{vert}) t_c (d)$$

where d = height of the shear wall

for an uncracked monolithic wall, this equation becomes

$$V_f(\text{vert}) = \frac{3}{2} \frac{V_f(\text{horiz})}{b} (d)$$

where b = the length of the shear wall

The factored longitudinal shear resistance, for a wall without horizontal bars, is based on the shear capacity for the concrete area in the joints between components, which is the area of the coring in the webs.

$$V_r = \frac{2}{3} 0.2 \phi_c \sqrt{f'_c} (0.80 A_{c\text{vert}}) \quad (\text{CSA A23.3 Eq. 22-3})$$

where $\phi_c = 0.60$

$$\phi V_n = \phi \frac{4}{3} \sqrt{f'_c} (0.80 A_{c\text{vert}}) \quad (\text{ACI 318 Eq. 22-8})$$

where $\phi = 0.55$

The factored longitudinal shear resistance, for a wall with horizontal bars, is based on the shear friction capacity at the joints between components. Ignoring cohesion and loads normal to the cross section the following is suggested as factored shear resistance.

$$V_r = \phi_c A_s f_y \mu \quad (\text{CSA A23.3 Eq. 11-32})$$

where $\phi_c = 0.60$

$\mu = 1.40$

$$\phi V_n = \phi A_{vf} f_y \mu \quad (\text{ACI 318 Eq. 11-25})$$

where $\phi = 0.75$

$\mu = 1.40$

5.4 Walls Designed as Plain Concrete

The physical properties of walls with Conform designed as plain concrete are shown in Tables 5.3 to 5.6.

The values are based on the following equations:

Concrete Properties

- $M_{cr} = f_r S_c$
 where $f_r = 0.6 \sqrt{f'_c}$ (Metric)
 $f_r = 7.5 \sqrt{f'_c}$ (Imperial)
- $M_{rc} = 0.4 \phi_c \sqrt{f'_c} S_c$ (Metric)
 $= \phi 5 \sqrt{f'_c} S_c$ (Imperial)
- $V_{rh/c} = \frac{2}{3} (0.2) \phi_c \sqrt{f'_c} A_c$ (Metric)
 where $\phi_c = 0.6$
- $V_{rh/c} = \phi \frac{4}{3} \sqrt{f'_c} A_c$ (Imperial)
 where $\phi = 0.55$
- $V_{rv/c} = \frac{2}{3} (0.2) \phi_c \sqrt{f'_c} (0.8) A_{c\text{vert}}$ (Metric)
 where $\phi_c = 0.6$
- $V_{rv/c} = \phi \frac{4}{3} \sqrt{f'_c} A_{c\text{vert}}$ (Imperial)
 where $\phi = 0.55$

Table 5.3 Strength Properties of CF4 Walls

Properties	Metric Values per metre	Properties	Imperial Values per foot
Plain Concrete		Plain Concrete	
	f'_c = 20 MPa		f'_c = 3000 psi
E _c	20125 MPa	E _c	3.122 10 ⁶ psi
EI _c	1364.9 10 ⁹ N·mm ²	EI _c	155.0 10 ⁶ lb·in ²
M _{cr}	3.83 kN·m	M _{cr}	910 ft·lb
M _{r/c}	1.53 kN·m	ϕM _{n/c}	334 ft·lb
V _{rh/c}	32.3 kN	ϕV _{nh/c}	1714 lb
V _{rv/c}	11.3 kN	ϕV _{nv/c}	601 lb
Plain Concrete		Plain Concrete	
	f'_c = 25 MPa		f'_c = 4000 psi
E _c	22500 MPa	E _c	3.605 10 ⁶ psi
EI _c	1526.0 10 ⁹ N·mm ²	EI _c	179.0 10 ⁶ lb·in ²
M _{cr}	4.29 kN·m	M _{cr}	1051 ft·lb
M _{r/c}	1.71 kN·m	ϕM _{n/c}	385 ft·lb
V _{rh/c}	36.1 kN	ϕV _{nh/c}	1979 lb
V _{rv/c}	12.7 kN	ϕV _{nv/c}	694 lb

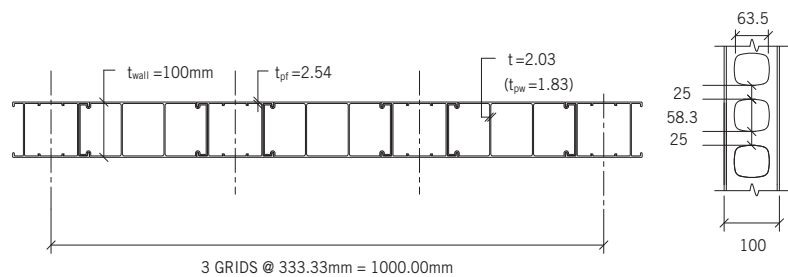

Fig. 5.3

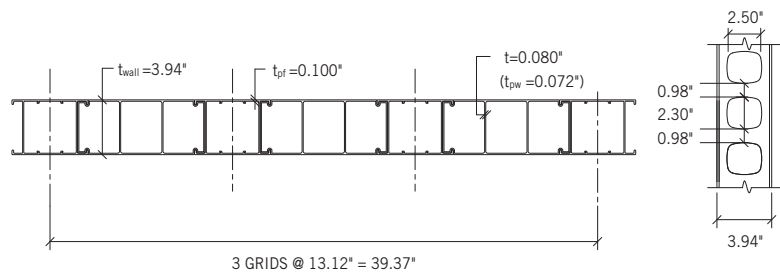

Fig. 5.3a

Table 5.4 Strength Properties of CF6 Walls

Properties	Metric Values per metre	Properties	Imperial Values per foot
Plain Concrete		Plain Concrete	
$f'_c = 20 \text{ MPa}$		$f'_c = 3000 \text{ psi}$	
E_c	20125 MPa	E_c	3.122 10^6 psi
EI_c	4878.1 $10^9 \text{ N}\cdot\text{mm}^2$	EI_c	554.2 $10^6 \text{ lb}\cdot\text{in}^2$
M_{cr}	8.98 kN·m	M_{cr}	2130 ft·lb
$M_{r/c}$	3.59 kN·m	$\phi M_{n/c}$	781 ft·lb
$V_{rh/c}$	49.6 kN	$\phi V_{nh/c}$	2628 lb
$V_{rv/c}$	20.1 kN	$\phi V_{nv/c}$	1065 lb
Plain Concrete		Plain Concrete	
$f'_c = 25 \text{ MPa}$		$f'_c = 4000 \text{ psi}$	
E_c	22500 MPa	E_c	3.605 10^6 psi
EI_c	5453.8 $10^9 \text{ N}\cdot\text{mm}^2$	EI_c	639.9 $10^6 \text{ lb}\cdot\text{in}^2$
M_{cr}	10.04 kN·m	M_{cr}	2459 ft·lb
$M_{r/c}$	4.01 kN·m	$\phi M_{n/c}$	902 ft·lb
$V_{rh/c}$	55.4 kN	$\phi V_{nh/c}$	3035 lb
$V_{rv/c}$	22.5 kN	$\phi V_{nv/c}$	1230 lb

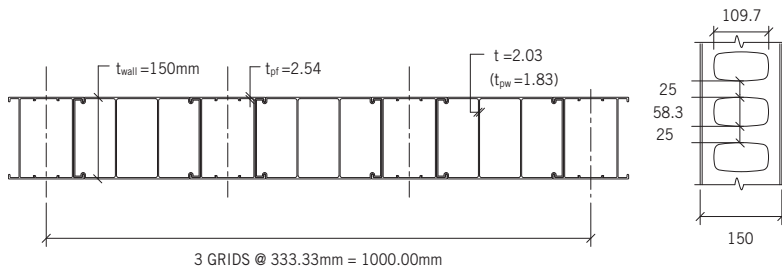

Fig. 5.4

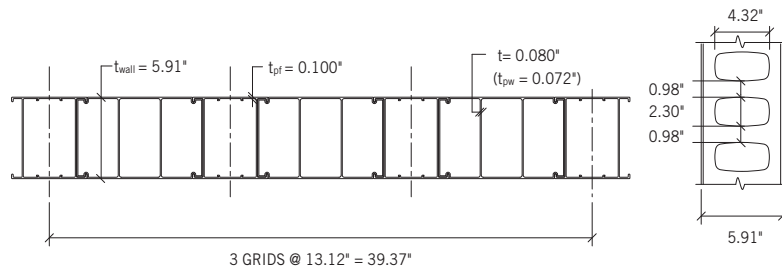

Fig. 5.4a

Table 5.5 Strength Properties of CF8 Walls

Properties	Metric Values per metre	Properties	Imperial Values per foot
Plain Concrete		Plain Concrete	
	f'_c = 20 MPa		f'_c = 3000 psi
E _c	20125 MPa	E _c	3.122 10 ⁶ psi
EI _c	11909.2 10 ⁹ N·mm ²	EI _c	1352.9 10 ⁶ lb·in ²
M _{cr}	16.29 kN·m	M _{cr}	3866 ft·lb
M _{r/c}	6.52 kN·m	ϕM _{n/c}	1418 ft·lb
V _{rh/c}	66.8 kN	ϕV _{nh/c}	3543 lb
V _{rv/c}	28.3 kN	ϕV _{nv/c}	1501 lb
Plain Concrete		Plain Concrete	
	f'_c = 25 MPa		f'_c = 4000 psi
E _c	22500 MPa	E _c	3.605 10 ⁶ psi
EI _c	13314.6 10 ⁹ N·mm ²	EI _c	1562.2 10 ⁶ lb·in ²
M _{cr}	18.22 kN·m	M _{cr}	4464 ft·lb
M _{r/c}	7.29 kN·m	ϕM _{n/c}	1637 ft·lb
V _{rh/c}	74.7 kN	ϕV _{nh/c}	4091 lb
V _{rv/c}	31.7 kN	ϕV _{nv/c}	1734 lb

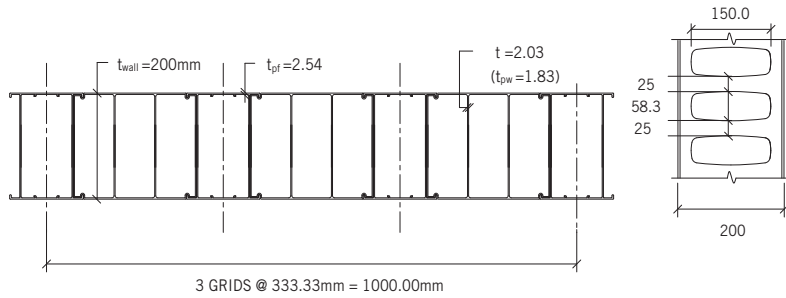

Fig. 5.5

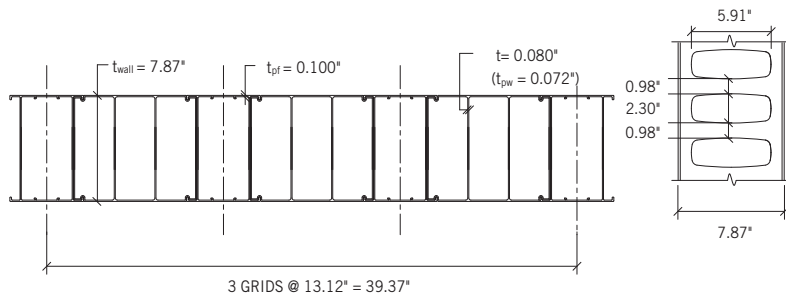

Fig. 5.5a

Table 5.6 Strength Properties of CF8i Walls

Properties	Metric Values per metre	Properties	Imperial Values per foot
Plain Concrete		Plain Concrete	
f'c = 20 MPa		f'c = 3000 psi	
E_c	20125 MPa	E_c	3.122 10^6 psi
EI_c	4322.6 10^9 N·mm ²	EI_c	491.1 10^6 lb·in ²
M_{cr}	8.30 kN·m	M_{cr}	1969 ft·lb
$M_{r/c}$	3.32 kN·m	$\phi M_{n/c}$	722 ft·lb
$V_{rh/c}$	47.8 kN	$\phi V_{nh/c}$	2535 lb
$V_{rv/c}$	20.1 kN	$\phi V_{nv/c}$	1065 lb
Plain Concrete		Plain Concrete	
f'c = 25 MPa		f'c = 4000 psi	
E_c	22500 MPa	E_c	3.605 10^6 psi
EI_c	4832.8 10^9 N·mm ²	EI_c	567.0 10^6 lb·in ²
M_{cr}	9.28 kN·m	M_{cr}	2274 ft·lb
$M_{r/c}$	3.71 kN·m	$\phi M_{n/c}$	834 ft·lb
$V_{rh/c}$	53.4 kN	$\phi V_{nh/c}$	2927 lb
$V_{rv/c}$	22.5 kN	$\phi V_{nv/c}$	1230 lb

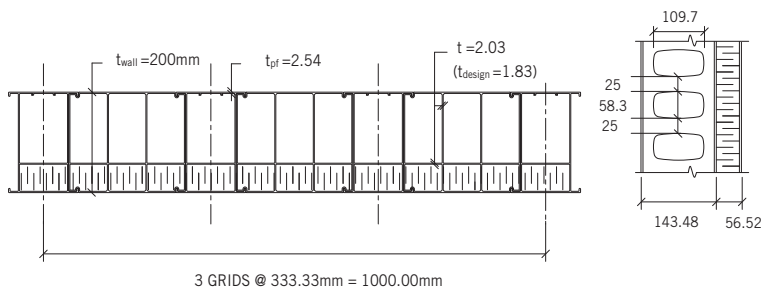

Fig. 5.6

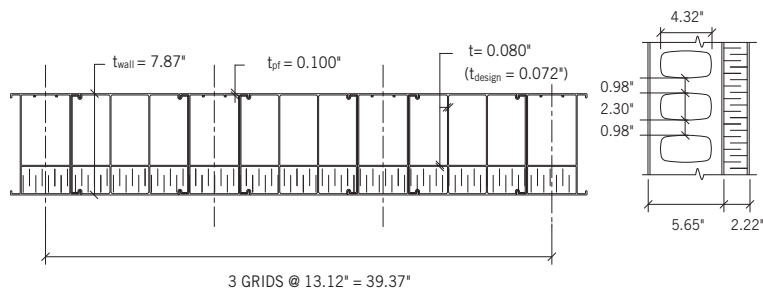

Fig. 5.6a

5.5 Fasteners for Walls with Conform

The permanent connection of a concrete filled wall using Conform to structural steel framing members can be accomplished with numerous conventional anchors. Typically, non-bearing walls are connected to steel girts with #14-10 x 3" screws, since these anchors are acceptable to connect the empty Conform components to the steel during erection. The spacing varies to suit the loads and the maximum recommended spacing is 400 mm. This anchorage method is non-ductile and is not recommended in earthquake zones higher than Zone 1, (Seismic Load > 0.05 x Dead Load).

Pullout Tension for #14-10 x 3" Screws ⁽¹⁾	
Factored Tension Resistance (T_r) (ϕT_n)	Allowable Service Tension
2.80 kN	1.87 kN
(629 lbs)	(420 lbs)

(1) Trow Report No BRBS-0006542-B, November 29,2001

6. Temporary Construction Conditions for Conform

6.0 Notation

Imperial	Metric	Definition	Imperial	Metric	Definition
	EI_p	= stiffness of polymer section		t_p	= total thickness of polymer section
	I_p	= moment of inertia of polymer section		T	= temperature of concrete in degrees Fahrenheit.
$(\phi M_{n/p})$	$M_{r/p}$	= factored moment resistance of polymer	(ϕT_n)	T_r	= factored tension resistance of anchor
(M_u)	M_f	= factored moment	(T_u)	T_f	= factored tension
	p	= hydraulic pressure of wet concrete in psf		T_{ult}	= ultimate tension resistance
	R	= rate of flow, height in feet per hour	(ϕV_n)	V_r	= factored shear resistance of anchor
	S_p	= section modulus of polymer section		V_{ult}	= ultimate shear resistance
				w_p	= weight of polymer section

6.1 General

This section discusses the design of the temporary conditions that occur during construction with Conform. During construction, the empty Conform components provide the formwork for the concrete and are subject to internal hydraulic pressure from the wet concrete and to external lateral forces from wind.

The design loads vary with the construction practices and the specific site conditions. However, even when the basic wall design and formwork are soundly conceived, small differences in assembly details and pouring methods may cause local weakness or overstress leading to partial failure. Therefore, one of the most effective means of achieving safety during the construction is to have competent supervision during erection and concrete placement.

6.2 Hydraulic Concrete Pressure

The Conform components provide permanent formwork to resist the hydraulic pressure on both faces of the wall. The webs tie the wall faces together and conventional form ties or snap ties are not required. The ability of the Conform components to resist the hydraulic pressure is determined by the thickness of the faces of the components. Based on the standard thickness of 2.54mm (0.100") and the polymer properties, it is recommended that the hydraulic pressure not exceed 29 kPa (600 psf).

The internal hydraulic pressure on the Conform components from the wet concrete depends on several factors. In addition to the total height of the concrete to be placed in the wall, the temperature and rate of vertical placement of concrete will influence the development of internal hydraulic pressure. If the temperature drops during construction operations, the rate of construction often has to be slowed down to prevent a buildup of lateral pressure from overloading the components.

(1) ACI-SP4 Formwork for Concrete

For conventionally formed walls, the hydraulic pressure from concrete placed with minimal vibrations determined from the flow rate and the temperature ⁽¹⁾.

$$p = 100 + 6000(R/T)$$

This equation results in the following flow rates based on the maximum recommended pressure of 29 kPa (600 psf):

8 ft per hour at 96°F

6 ft per hour at 72°F

4 ft per hour at 48°F

It should be noted that the above flow rates may be exceeded for Conform, under suitable conditions. The numerous webs in the Conform components help to support the fresh concrete and reduce the hydraulic pressure. In some cases, walls 10m (32') high have been poured in less than a few minutes at flow rates of 5 m per minute (16 ft per minute)⁽²⁾. However, only construction personnel who are experienced with Conform and with the behaviour of the concrete being supplied should attempt high flow rates.

The slump of the concrete and the vibration of concrete affect the development of lateral pressures. Internal mechanical vibration can cause the hydraulic pressure to increase significantly and is not recommended. However, at anchor bolts, pockets and openings, a rubber mallet to tap the face of the wall or small external mechanical vibrators are recommended to ensure that there are no voids.

The flow rates and the faces of the components should be monitored during construction. Excessive flow rates or extremely high slumps may result in significant bowing of the face of the components, a bulge due to failure of a web, a blow-out due to failure of the wall face or longitudinal buckling of the wall components. The flow rates and/or slump should be reduced if bowing of the wall faces becomes significant.

Conventional formwork and bracing are required at wall openings, intersections and corners. This formwork must resist the hydraulic concrete pressures and the vertical weight of wet concrete being supported. The formwork must maintain the opening dimensions and the design should follow standard practices for conventional concrete formwork.

6.3 Lateral Wall Loads

During construction, the unfilled or empty Conform components for the walls of a building may be subjected to the same wind load as the walls of a finished structure. However, the wind load that is used for the design of a building under construction is usually less than the wind load for the finished structure. The contractor is responsible to ensure that the work is performed in a safe manner. Lateral wind loads depend on the site location and the prevalent weather conditions. Usually, lateral seismic loads are not considered since the weight of the empty Conform components is minimal.

The minimum recommended lateral load for temporary construction conditions is 0.50 kPa [10psf]. This value equates to a reference wind velocity of approximately 65 km/h [40 mph] and a maximum wind gust velocity of 90 km/h [55 mph]. However the designer should consider higher wind loads as warranted by the specific site conditions or local standards.

The factored moment resistance of the empty Conform components must be greater than the factored moment due to wind loads.

$$M_{r/p} \geq M_f \quad \text{(Metric)}$$

$$\phi M_{n/p} \geq M_u \quad \text{(Imperial)}$$

Also, the wall deflection and the capacity of the connections may govern the acceptability of empty Conform components during construction.

The axial load from the weight of the empty Conform components is negligible and, typically, the factored shear does not govern. Usually, these items are not considered.

Refer to Table 6.1 and Table 6.2 for the physical and strength properties of the empty Conform components.

(2) Trow Report BRBS-0006542-H, September 27, 2001

**Table 6.1 Properties of Empty Conform Components
(Polymer only) – Metric Units – per meter**

Conform	w_p	t_p	S_p	I_p	$M_{r/p}$	EI_p
	kN/m ²	mm	10 ³ mm ³	10 ⁶ mm ⁴	kN·m	10 ⁹ N·mm ²
CF4	0.12	100	311.2	15.56	4.98	56.0
CF6	0.13	150	497.2	37.33	7.96	134.4
CF8	0.14	200	698.0	64.80	11.17	251.3
CF8i	0.21 ⁽¹⁾	200	638.4	73.29	10.05	263.9

**Table 6.2 Properties of Empty Conform Components
(Polymer only) – Imperial Units – per foot**

Conform	w_p	t_p	S_p	I_p	$M_{r/p}$	EI_p
	lb/ft ²	in	in ³	in ⁴	ft·lb	10 ⁶ lb·in ²
CF4	2.48	3.94	5.79	11.40	1119	5.95
CF6	2.68	5.91	9.26	27.34	1790	14.27
CF8	2.91	7.87	12.98	51.12	2511	26.69
CF8i	4.36 ⁽¹⁾	7.87	11.68	53.68	2259	28.03

6.4 Temporary Bracing

The empty Conform components are laterally supported by temporary bracing or by connection to permanent structural steel framing.

The design of temporary structural bracing follows standard construction practices for temporary conditions. The size and location of walers, rakers and anchors are specific for each project and local site conditions.

For Conform, continuous horizontal walers are required at the top of the walls to keep the wall components aligned. For walls over 5.5 meters (18 feet) high, a second horizontal waler is provided near mid height to keep the empty components plumb before and during the concrete placement. The rakers are spaced at 2 to 3 meters (6 to 10 feet) on center and are connected to the walers.

(1) includes foam = 0.03kN/m² (0.55 psf)

The connection of the wall to the walers or permanent structural steel framing members is governed by the tension capacity of the fasteners to the face of the empty wall components. The factored tension resistance must be greater than the factored tension due to the wind loads.

$$T_r \geq T_f \quad (\text{Metric})$$

$$\phi T_n \geq T_u \quad (\text{Imperial})$$

The values in Table 6.3 and 6.4 provide a minimum factor of safety of 2.0 for service wind loads under temporary conditions. However, a higher safety factor may be required depending on local weather conditions and the length of time that the temporary conditions will exist. The resistance capacity of the screws should be adjusted accordingly.

Typically, the maximum spacing of fasteners is 400mm at the base and at the roof of two or more spans. The maximum spacing of fasteners is reduced to 200mm at the base and at the roof for walls over 4m high and at girts or walers of two or more spans.

The most frequent cause of wall failure during construction is inadequate connection to supporting members or inadequate bracing. There have been cases where damage could have been prevented or minimized if a small investment had been made on wall anchorage or bracing. Again, the most effective means of achieving safety during the construction is to have competent supervision during erection and concrete placement.

For construction and bracing procedures refer to the Conform Construction Guides.

**Table 6.3 Fasteners in Empty Conform Components
– Metric Units – per Screw**

Fastener Type	T_{ult}	V_{ult}	T_r	V_r
	kN	KN	kN	kN
#10-16 x 3/4" Screw	0.55 ⁽¹⁾	1.21 ⁽²⁾	0.41	0.91
#14-10 x 3" Screw	0.80 ⁽³⁾	1.21 ⁽⁴⁾	0.60	0.91

**Table 6.4 Fasteners in Empty Conform Components
– Imperial Units – per Screw**

Fastener Type	T_{ult}	V_{ult}	ϕT_n	ϕV_n
	lb	lb	lb	lb
#10-16 x 3/4" Screw	124 ⁽¹⁾	272 ⁽²⁾	93	204
#14-10 x 3" Screw	180 ⁽³⁾	272 ⁽⁴⁾	135	204

(1) Trow Report No. BR-06542-B, T94-14, September 7, 1994

(2) Trow Report No. BR-06542-B, T95-3A, July 31, 1995

(3) Trow Report No. BRBS-0006542-B, November 29, 2001

(4) Assumed same as #10 x 3/4" screw

7. Illustrative Examples of Walls with Conform

7.1 Example #1 – CF8i Non-Bearing Wall (8300 mm)

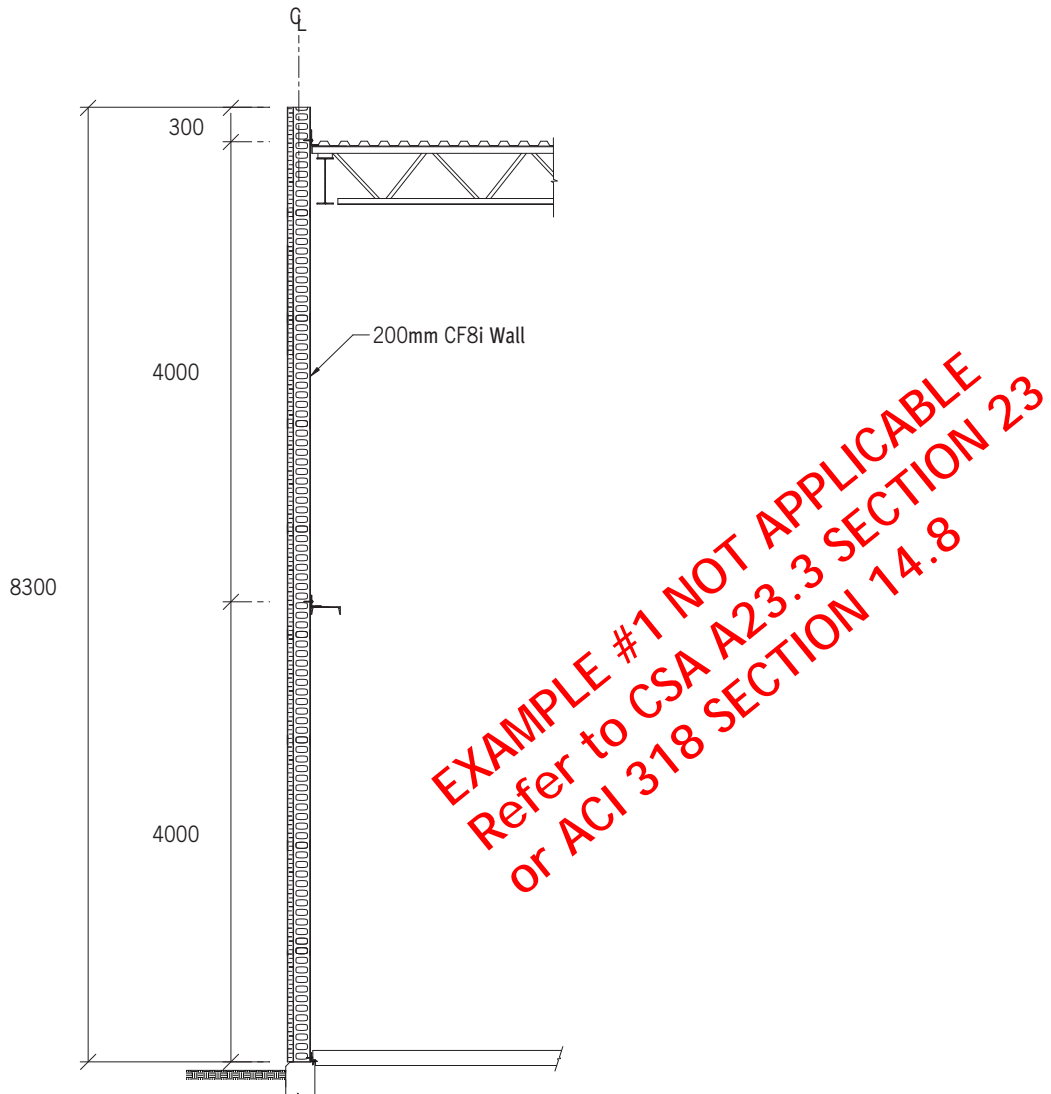

Fig. 7.1

7.1.1 Design for lateral load due to wind based on the following assumptions:

- National Building Code of Canada
- CSA Standard A23.3
- Lateral Wind Load (W)
 - Wind pressure (p) = ± 1.15 kPa (1 in 30 year wind for strength)
 - (p) = ± 0.93 kPa (1 in 10 year wind for deflection)
- $f'_c = 25$ MPa
- Non-Fire Rated, Non-Combustible Construction
- Polymer reinforced concrete is acceptable for non-bearing walls

7.1.2 Check Slenderness Ratio

- Slenderness ratio of wall

$$\frac{kl_u}{r_c} = \frac{1.0(4000)}{40.10} = 99.8 \quad (\text{Table 3.4})$$

Since $\frac{kl_u}{r_c} \leq 150$, consider design based on moment magnification method (Fig. 5.1)

7.1.3 Calculate Axial Load

- Factored axial load at midspan between foundation and girt from self weight.

$$P_f = (w_f) \left(l_{\text{total}} - \frac{l_u}{2} \right) = (1.25)(3.41) \left(8.3 - \frac{4.0}{2} \right) = 26.9 \text{ kN/m} \quad (\text{Table 3.4})$$

- Check axial concrete stress

$$\frac{P_f}{A_c} = \frac{(26.9)(1000)}{133577} = 0.20 \text{ MPa} \quad (\text{Table 3.4})$$

- For compressive stresses not greater than $0.09\phi_c f'_c = (0.09)(0.6)(25) = 1.35 \text{ MPa}$, combined axial and flexural effects are ignored and design is based on the maximum factored moment including P-Δ effects. (CSA A23.3, Eq. 23-1)

$$\frac{P_f}{A_c} \leq 1.35 \text{ MPa,}$$

- Therefore consider design based on magnified factored moment.

-OK-

7.1.4 Check Flexural Moment

- Factored Moment at Girt (full wind load)

$$M_f = \frac{P_f l_u^2}{8} = \frac{(1.5)(-1.15)(4.0)^2}{8} = -3.45 \text{ kN}\cdot\text{m/m}$$

- Factored Moment at Midspan (unbalanced wind loading and P-Δ effects due to slenderness)

- Without P-Δ effects

$$M_f = \frac{P_f l_u^2}{11} = \frac{(1.5)(-1.15)(4.0)^2}{11} = +2.51 \text{ kN}\cdot\text{m/m}$$

M_f considered conservative for two span condition with 25% unbalanced load and large span not more than 20% greater than short span.

- With P-Δ effects

$$+M_f = M_b \delta_b$$

(CSA A23.3, Eq. 23-2)

Where $\Delta_o = 0.015 + 0.002 l_u = 0.015 + (0.002)(4.0) = 0.023 \text{ m}$

$$M_b = M_f + P_f \Delta_o = 2.51 + (26.9)(0.023) = 3.13 \text{ kN}\cdot\text{m/m}$$

$$K_b = \frac{48EI}{5l_u^2} = \frac{(48)(292.4 \times 10^9)}{(5)(4000^2)} = 175.4 \times 10^3 \text{ N}$$

(CSA A23.3, Eq. 23-6)

The bending stiffness at failure = $EI_{pc} = 292.4 \times 10^9 \text{ N}\cdot\text{mm}^2/\text{m}$ (Table 6.4)

$$\delta_b = \frac{1}{1 - \left(\frac{P_f}{\phi_m K_b} \right)} = \frac{1}{1 - \left(\frac{26.9 \times 10^3}{(0.65)(175.4 \times 10^3)} \right)} = 1.309 \quad (\text{CSA A23.3, Eq. 23-4})$$

$$M_f = (3.13)(1.309) = 4.10 \text{ kN}\cdot\text{m}/\text{m}$$

Therefore $M_f \text{ max} = M_f \text{ at midspan} = 4.10 \text{ kN}\cdot\text{m}/\text{m}$

- Factored Moment Resistance of uncracked concrete

$$M_r = M_{rc} + P_f \left(\frac{t}{2} \right) \quad (\text{CSA A23.3, cl. 23.4.1.5})$$

Where $M_{rc} = 3.71 \text{ kN}\cdot\text{m}/\text{m}$ (Table 5.6)

$$P_f = (1.25)(3.41)(4.3) = 18.3 \text{ kN}/\text{m}$$

$$t = t_c = 138.9 \text{ mm}$$

$$M_r = 3.71 + (18.3) \left(\frac{0.1389}{2} \right) = 4.98 \text{ kN}\cdot\text{m}/\text{m}$$

- Therefore $M_r \geq M_f \text{ max}$ -OK-

7.1.5 Check Deflection

- Deflection is based on 1 in 10 year wind pressure

Consider service moment at mid-span between foundation and girt due to unbalanced wind loading and P- Δ effects:

$$M_s = (M_{bs} + P_s \Delta_o) \delta_b$$

$$\text{Where } M_{bs} = \frac{p_s l_u^2}{11} = \frac{(0.93)(4^2)}{11} = 1.35 \text{ kN}\cdot\text{m}/\text{m}$$

$$P_s = (w)(l_{\text{total}} - \frac{l_u}{2}) = (3.41)(8.3 - \frac{4.0}{2}) = 21.5 \text{ kN}/\text{m}$$

$$\Delta_o = 0.023 \text{ m}$$

Conservatively assume $\delta_b = 1.309$ as previous

$$M_s = \{1.35 + (21.5)(0.023)\} 1.309 = 2.41 \text{ kN}\cdot\text{m}/\text{m}$$

Since $M_s < M_{rc} = 3.71 \text{ kN}\cdot\text{m}/\text{m}$, the concrete is considered uncracked (Table 5.6)

Therefore, $EI = 0.70 EI_c$ for non-sustained loads = $0.70 (4832.8 \times 10^9) = 3383.0 \times 10^9 \text{ N}\cdot\text{mm}^2$ (Table 5.6)

$$\Delta_s \approx \frac{5M_s l_u^2}{48EI} = \frac{(5)(2.41)(4.0^2)(10^{12})}{(48)(3383.0 \times 10^9)} = 1.2 \text{ mm}$$

- Assume allowable deflection is 1/150 of span

$$\Delta_a = \frac{4000}{150} = 26.7 \text{ mm}$$

- Therefore $\Delta_a \geq \Delta_s$ -OK-

7.1.6 Check Shear

- Factored shear at girt governs

$$V_f = p_f(0.625)(l_u) = (1.5)(1.15)(0.625)(4.0) = 4.31 \text{ kN/m}$$

- Shear resistance of plain concrete at girt (horizontal)

$$V_{rh/c} = 53.4 \text{ kN/m}$$

(Table 5.6)

- Therefore $V_{rh/c} \geq V_f$

-OK-

7.1.7 Check Connections

- Connection at roof, #14x3" screws @ 400 o/c

$$T_f \approx p_f \frac{(l_u + a)^2}{2l_u} (s) = (1.5)(1.15) \frac{(4.0 + 0.3)^2}{(2)(4.0)} (0.40) = 1.59 \text{ kN/screw}$$

$$T_r = 2.80 \text{ kN/screw}$$

(Table 5.7)

- Therefore $T_r \geq T_f$

-OK-

- Connection at girt, #14x3" screws @ 200 o/c

$$T_f \approx 1.25p_f l_u (s) = (1.25)(1.5)(1.15)(4.0)(0.20) = 1.33 \text{ kN/screw}$$

$$T_r = 2.80 \text{ kN/screw}$$

(Table 5.7)

- Therefore $T_r \geq T_f$

-OK-

- Connection at base, 15M dowels @ 400 o/c

$$V_f \approx p_f(0.5)(l_u)(s) = (1.5)(1.15)(0.5)(4.0)(1.0) = 3.45 \text{ kN/m}$$

$$V_r = (\phi_c)(\mu)(A_s)(F_y) = (0.6)(0.6)(200)(400)(10^{-3}) = 28.8 \text{ kN/m}$$

- Therefore $V_r \geq V_f$

-OK-

7.1.8 Other Considerations

Other items, as required, shall be included in the wall design, such as:

- Lateral seismic loads, specifically loads on non-ductile connections
- Lateral loads adjacent to openings and at piers between openings
- Lateral and vertical loads on headers that span across openings
- Equipment loads suspended from walls
- Temporary load conditions during construction. See Section 6.0 and Section 7.0 Example #2

EXAMPLE #1 NOT APPLICABLE
Refer to CSA A23.3 SECTION 23
of ACT 318 SECTION 14.8

7.2 Example #2 – CF8i Construction Conditions (8300 mm)

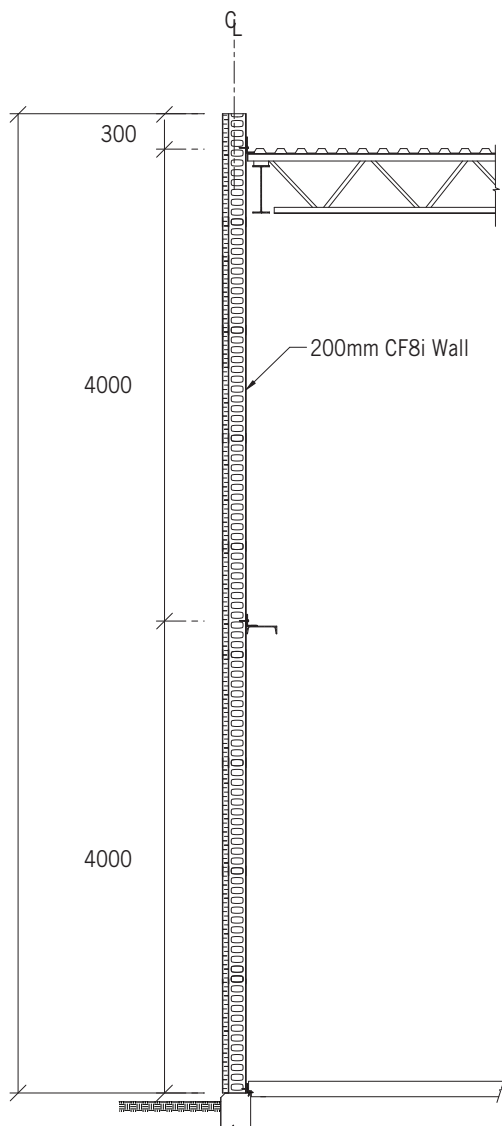

Fig. 7.2

7.2.1 Design for lateral load due to wind based on the following assumptions

- National Building Code of Canada
- Temporary Lateral Wind Load (W)
 - Wind pressure (p) = ± 0.48 kPa

7.2.2 Check Flexural Moment

- For void wall self-weight is negligible and slenderness effect is ignored. Flexural moments, only, are considered.
- Factored moment at girt (full wind loading)

$$M_f = \frac{p_f l_u^2}{8} = \frac{1.5(-0.48)(4.0)^2}{8} = -1.44 \text{ kN}\cdot\text{m/m}$$

- Factored moment at mid-span (unbalanced wind loading)

$$+M_f = \frac{p_f l_u^2}{11} = \frac{1.5(0.48)(4.0)^2}{11} = 1.05 \text{ kN}\cdot\text{m/m}$$

Considered conservative for 2 span conditions with 25% unbalanced load and large span not more than 20% greater than short span.

Therefore $M_f \text{ max} = M_f \text{ at girt} = 1.44 \text{ kN}\cdot\text{m/m}$

- Factored moment resistance of polymer

$$M_{r/p} = 10.05 \text{ kN}\cdot\text{m/m} \quad (\text{Table 6.1})$$

- Therefore $M_{r/p} \geq M_f$

-OK-

7.2.3 Check Deflection

- Consider service moment at mid-span between supports.

$$M_s \approx \frac{p_l l_u^2}{11} = \frac{0.48(4)}{11} = 0.55 \text{ kN}\cdot\text{m/m}$$

$$\Delta_s \approx \frac{5M_l l_u^2}{48 EI} = \frac{5(0.55)(4.0^2) \times 10^{12}}{48 \times 263.9 \times 10^9} = 3.5 \text{ mm} \quad (\text{Table 6.1})$$

- Assume allowable deflection 1/120 of span.

$$\Delta_a = 4000/120 = 33.3 \text{ mm}$$

- Therefore $\Delta_a \geq \Delta_s$

-OK-

7.2.4 Check Connections

- Connection at roof #14x3" screws @ 333 mm.

$$T_f \approx (p_f) \frac{(l_u + a)^2}{2(l_u)} (s) = 1.5 (.48) \frac{(4.0 + 0.3)^2}{(2)(4.0)} (.333) = 0.55 \text{ kN/screw}$$

$$T_r = 0.60 \text{ kN/screw} \quad (\text{Table 6.3})$$

- Therefore $T_r \geq T_f$

-OK-

- Connection at girt #14x3" screw @ 167 mm

$$T_f \approx 1.25 (p_f) l_u (s) = 1.25(1.5)(0.48)(4.0)(0.167) = 0.60 \text{ kN/screw}$$

$$T_r = 0.60 \text{ kN/screw} \quad (\text{Table 6.3})$$

- Therefore $T_r \geq T_f$

-OK-

- Connection at base, #14x3" screw @ 400 mm

$$T_f \approx (p_f) \frac{l_u}{2} (s) = 1.5 (0.48) \frac{4.0}{2} (0.400) = 0.58 \text{ kN/screw}$$

$$T_r = 0.60 \text{ kN/screw} \quad (\text{Table 6.3})$$

- Therefore $T_r \geq T_f$

-OK-

7.3 Example #3 – CF8i Foundation Wall (8'-1")

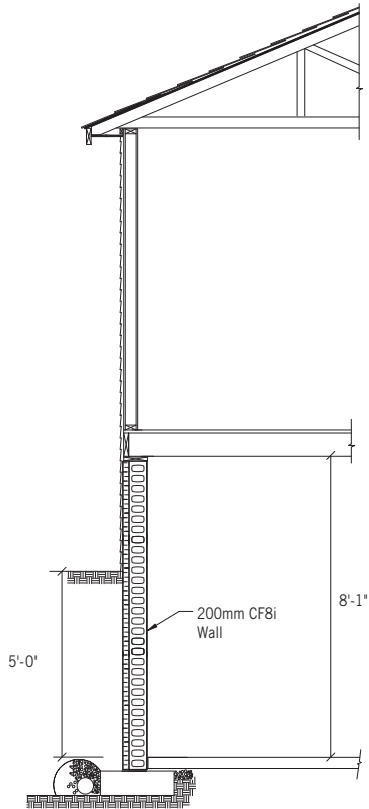

Fig. 7.3a

7.3.1 Design for lateral load due to soil pressure based on the following assumptions

- ACI Standard 318
- Superimposed Axial Loads (D) (L)
 - Dead load = 365 lbs/ft
 - Live load = 615 lbs/ft
- Lateral Soil Load (H)
 - Density = 100 psf
 - Surcharge = 50 psf
 - Equivalent soil pressure coefficient = 0.30
- $f'_c = 2500$ psi
- Combustible Type 5 Unprotected Construction
- Use unreinforced concrete for sustained loads such as lateral soil pressure

7.3.2 Check Slenderness Ratio

Slenderness ratio of wall

$$\frac{kl_c}{r_c} = \frac{1.0 (8.08) 12}{1.58} = 61.4 \quad (\text{Table 3.4})$$

Since $\frac{kl}{r} \leq 75$, consider design based on ACI 318 Section 22.5. (Figure 5.2)

7.3.3 Calculate Axial Load

- Factored axial load at mid height from self weight and superimposed loads

$$\text{Self Weight} = P = w \frac{l_c}{2} = (71.2) \frac{8.08}{2} = 288 \text{ lbs/ft} \quad (\text{Table 3.4})$$

- For Load Case 1.2D + 1.6L + 1.6H

$$P_u = 1.2 (288 + 365) + 1.6 (615) = 1768 \text{ lbs/ft}$$

- For Load Case 0.9D + 1.6H

$$P_u = 0.9 (288+365) = 588 \text{ lbs/ft}$$

7.3.4 Calculate Flexural Moment

- Factored moment due to lateral soil pressure.

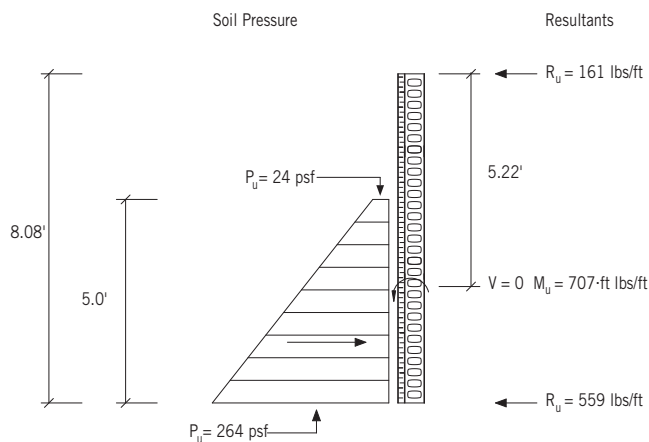

Fig. 7.3b

$$V_u = 0 \text{ at } x = 5.22 \text{ ft from top}$$

$$M_u = 707 \text{ ft}\cdot\text{lbs/ft}$$

7.3.5 Check Stress at Compression Face from Flexure and Maximum Axial Load

- Factored compression stress = $\frac{M_u}{S_c} + \frac{P_u}{A_c} = \frac{707 (12)}{57.52} + \frac{1768}{63.11} = 175.5 \text{ psi}$
- Factored compression resistance stress = $\phi (0.60) f'_c [1 - (\frac{l_c}{32 t})^2]$ (ACI 318 Eq. 22.5)

$$= 0.55 (0.6) (2500) [1 - (\frac{(8.08) 12}{32 (5.47)})^2] = 571.9 \text{ psi}$$
- Factored compression resistance stress \leq Factored compression stress. **-OK-**

7.3.6 Check Stress at Tension Face from Flexure and Minimum Axial Load

- Factored tension stress = $\frac{M_u}{S_c} - \frac{P_u}{A_c} = \frac{707 (12)}{57.52} - \frac{588}{63.11} = 138.2 \text{ psi}$ (Table 3.4.)

- Factored tension resistance stress = $\phi (5.0) \sqrt{f'_c} = 0.55 (5) \sqrt{2500} = 137.5$ psi (ACI 318 Eq. 29.2)
- Factored tension resistance stress \approx Factored tension stress.
- Overstress of 0.5% is negligible and is ignored. Therefore wall is acceptable. **-OK-**

7.3.7 Check Deflection

- Deflection is based on long term sustained soil pressure.

$$M_s = \frac{M_u}{1.6} = \frac{707}{1.6} = 442 \text{ ft}\cdot\text{lbs/ft}$$

$$\Delta_s \approx \frac{5M_s l^2}{48EI} = \frac{(5) (442 \times 12)(97^2)}{(48) (149.4 \times 10^6)} = 0.03 \text{ in} \quad (\text{ACI 318 Eq 14.9})$$

$$\text{where } EI = \frac{EI_c}{1 + B_D} = \frac{(57,000 \sqrt{2500}) (157.29)}{(1+2)} = 149.4 \times 10^6 \text{ lb}\cdot\text{in}^2 \quad (\text{Table 3.4.})$$

$B_D = 2.0$ for long term deflection due to sustained loads

- Assume allowable deflection is 1/150 of span for walls. (ACI 318 cl 14.8.4)

$$\Delta_a = 97/150 = 0.65 \text{ in}$$

- Therefore $\Delta_a \geq \Delta_s$ **-OK-**

7.3.8 Check Shear

- Factored Shear at base of wall

$$V_u = R_u = 559 \text{ lbs/ft} \quad (\text{Figure 7.3b})$$

- Factored Shear Resistance of wall

$$\phi V_u = \phi \left(\frac{4}{3} \right) \sqrt{f'_c} A_c = 0.55 \left(\frac{4}{3} \right) \sqrt{2500} 63.11 = 2314 \text{ lbs/ft} \quad (\text{ACI 318 Eq 22.9})$$

- Factored Shear Resistance of Dowels #5@2' 2" on center

$$\phi V_n = \phi A_{vf} f_y \mu = 0.75 \left(\frac{0.31}{2.17} \right) (60 \times 10^3)(0.6) = 3857 \text{ lbs/ft} \quad (\text{ACI 318 cl 11.7.4.1})$$

- Therefore $\phi V_n \geq V_u$ **-OK-**

7.3.9 Other Considerations

Other items, as required, shall be included in the wall design, such as:

- Lateral loads adjacent to openings and at piers between openings
- Lateral and vertical loads on headers that span across openings
- Concentrated vertical loads on walls
- Temporary conditions during construction. See Section 6.0

References

- Design of Concrete Structures
CSA A23.3-94
Canadian Standards Association
1994
- Building Code Requirements for Structural Concrete
and Commentary
ACI 318-02
American Concrete Institute
First Printing, 2002
- PCI Design Handbook
Precast/Prestressed Concrete Institute
Fifth Edition, 1999
- Tilt-Up Concrete Structures
ACI 551R-92
American Concrete Institute
First Printing, 1992
- Insulating Concrete Forms for Residential
Design and Construction
Pieter A. VanderWerf ... [et al.]
McGraw-Hill, 1997
- Formwork for Concrete
ACI-SP4
American Concrete Institute
6th Edition, M. K. Hurd, 1995
- Practitioner's Guide to Tilt-Up Concrete Construction
American Concrete Institute
Second Printing, 1998
- Minimum Design Loads for Buildings and Other Structures
AISC 7
American Society of Civil Engineers
2000
- National Building Code of Canada (NBC)
National Research Council of Canada
2005
- International Building Code (IBC)
International Code Council (ICC)
2006

APPENDIX A – Conversion Table

Table of Conversions – Metric vs Imperial

Metric Units	Multiply by	Imperial Units	Multiply by	Metric Units
Length				
mm	0.03937	in	25.400	mm
mm ²	1.550 x 10 ⁻³	in ²	0.6452 x 10 ³	mm ²
mm ³	0.06102 x 10 ³	in ³	16.39 x 10 ³	mm ³
mm ⁴	2.403 x 10 ⁻⁶	in ⁴	0.4162 x 10 ⁶	mm ⁴
mm ² /m	0.4724 x 10 ⁻³	in ² /ft	2.117 x 10 ³	mm ² /m
mm ³ /m	0.0186 x 10 ⁻³	in ³ /ft	53.763 x 10 ³	mm ³ /m
mm ⁴ /m	0.7323 x 10 ⁻³	in ⁴ /ft	1.3656 x 10 ³	mm ⁴ /m
m	3.2808	ft	0.30480	m
m ²	10.764	ft ²	0.09290	m ²
m ³	1.30814	yd ³	0.7644	m ³
Mass				
kg	2.205	lb	0.4536	kg
kg/m	0.6719	lb/ft	1.488	kg/m
kg/m ²	0.2048	lb/ft ² (psf)	4.883	kg/m ²
kg/m ³	0.06242	lb/ft ³ (pcf)	16.021	kg/m ³
kg/m ³	1.6853	lbs/yd ³	0.59335	kg/m ³
Force				
kgf	0.2248	lb _f	4.448	kg _f
N	0.2248	lb _f	4.448	N
kN	224.8	lb _f	4.448 x 10 ³	kN
kN/m	68.52	lb _f /ft	0.01459	kN/m
kg _f /m ²	0.02089	lb _f /ft ²	48.81	kg _f /m ²
kPa (kN/m ²)	20.89	lb _f /ft ²	0.04788	kPa (kN/m ²)
MPa	145.03	lb _f /in ² (psi)	6.895 x 10 ⁻³	MPa
kN/m ³	6.366	lb _f /ft ³	0.1571	kN/m ³
Moment				
kN·m	0.7376	ft·Kips	1.356	kN·m
kN·m/m	224.8	ft·lb _f /ft	4.448 x 10 ³	kN·m/m
Stiffness				
N·mm ² /m	0.1062 x 10 ⁻³	lb·in ² /ft	9.415 x 10 ³	N·mm ² /m

Table of Conversions – Metric to Metric

Metric Units	Multiply by	Metric Units	Multiply by	Metric Units
kN/m	1.00	N/mm	1.00	kN/m
kPa	102.0	kg _f /m ²	9.807 x 10 ⁻³	kPa
MPa	1.00	N/mm ²	1.00	MPa

Table of Conversions – Mass to Weight

Units	Multiply by	Units	Multiply by	Units
kg	9.806	kg _f	0.1020	kg
kg	9.806 x 10 ⁻³	kN	102.0	kg
lb	1.00	lb _f	1.00	lb

APPENDIX B – General Information

Material Density

Material	Metric kg/m ³	Metric kN/m ³	Imperial lb _f /ft ³
Water	1000	9.806	62.4
Polymer	1470	14.42	91.8
Concrete	2323	22.78	145
Steel	7850	76.98	490

CSA Steel Reinforcing Bars – Metric Designation

Bar Size	Nominal Diameter mm	Nominal Area mm ²	Nominal Mass kg/m
10M	11.3	100	0.785
15M	16.0	200	1.570
20M	19.5	300	2.355
25M	25.2	500	3.925
30M	29.9	700	5.495

ASTM Steel Reinforcing Bars – Imperial Designation

Bar Size	Nominal Diameter in	Nominal Area in ²	Nominal Weight lb/ft
#3	0.375	0.11	0.376
#4	0.500	0.20	0.668
#5	0.625	0.31	1.043
#6	0.750	0.44	1.502
#7	0.875	0.60	2.044
#8	1.000	0.79	2.670
#9	1.128	1.00	3.400

Quantity of Concrete – Metric Units

Conform	CF4	CF6	CF8	CF8i
Square Metres of Wall Area Per Cubic Metre of Concrete	11.1 m ²	7.2 m ²	5.4 m ²	7.5 m ²
Cubic Metres of Concrete Per Square Metre of Wall Area	0.0903 m ³	0.1385 m ³	0.1867 m ³	0.1336 m ³

Quantity of Concrete – Imperial Units

Conform	CF4	CF6	CF8	CF8i
Square Feet of Wall Area Per Cubic Yard of Concrete	91 ft ²	59 ft ²	44 ft ²	61 ft ²
Cubic Yards of Concrete Per Square Foot of Wall Area	0.0110 yd ³	0.0169 yd ³	0.0227 yd ³	0.0164 yd ³

Notes

Notes

Notes

We hope you found this guide informative while designing your project using Conform.

As always, our main goal at Nuform Building Technologies Inc. is to ensure that our valued customers are 100% satisfied with our service and with Conform. Should you have any questions or comments, we would like to hear from you. You may contact us at the following:

Please visit the Technical Resource Center section of our Web site at www.nuformdirect.com for the latest version of this guide. Please forward us any suggestions or comments for improving this guide. All suggestions for improvements will be given full consideration for future revisions.

PURCHASER IS SOLELY RESPONSIBLE FOR DETERMINING THE SUITABILITY FOR USE OR APPLICATION OF ANY GOODS, INCLUDING COMPONENTS THEREOF, OR WHETHER SUCH GOODS MEET REQUIREMENTS OF APPLICABLE BUILDING CODES OR SAFETY CODES FOR SPECIFIC APPLICATIONS.



The Revolutionary Stay-in-Place
Concrete Wall Formwork

For more photos and information, visit our Web site at
www.nuformdirect.com



Nuform Building Technologies Inc.

1 Regalcrest Court
Woodbridge, Ontario, Canada
L4L 8P3

Toll Free: 1 877-747-WALL (9255)
Tel.: 905-652-0001
Fax: 905-652-0002

PURCHASER IS SOLELY RESPONSIBLE
FOR DETERMINING THE SUITABILITY
FOR USE OR APPLICATION OF ANY
GOODS, INCLUDING COMPONENTS
THEREOF, OR WHETHER SUCH GOODS
MEET REQUIREMENTS OF APPLICABLE
BUILDING CODES OR SAFETY CODES
FOR SPECIFIC APPLICATIONS.